



eDELIVER 9 维修手册

eDELIVER 9 Service Workbook



SAIC MOTOR

2020 Year

<https://www.automotive-manuals.net>

Foreword

This Manual briefly introduces the main technical configuration of eDELIVER 9 Pure Electric Vehicle, vehicle use, driving and operation, assembly and adjustment of each part and relevant points in preventive maintenance, and be referred to for implementation.

With the continuous progress of technology, eDELIVER 9 Pure Electric Vehicle will continue to be improved and perfected, we will enrich and adjust the relevant contents of this manual in due time. In the process of using and maintaining the vehicle, if you find any deficiencies, please contact us in time for continuous improvement and perfection.

Caution for eDELIVER 9

Caution; to minimize the possibility of personal injury and property damage, be sure to follow the following instructions carefully:

The Service Manual for eDELIVER 9 Pure Electric Vehicle is prepared by the SAIC MAXUS Automotive Co., Ltd. for qualified professional technicians. Attempting repairs or service without the appropriate training, tools, and equipment could cause injury to you or others. Moreover, it may damage the vehicle or cause abnormal operation of the vehicle.

Proper vehicle service and repair are important to the safety of the service technician and to the safe, reliable operation of all motor vehicles. For the replacement of the part, the new one with the same part number or that designated by SAIC MAXUS Automotive Co., Ltd. is recommended. DO NOT use the replacement part which is not approved by SAIC MAXUS Automotive Co., Ltd.

The Service Guide recommended and introduced in this Manual provides an effective method for repairing and servicing vehicles. Special tools may sometimes be necessary.

Thus, before using any replacement part, the Service Guide or tools approved or recommended by SAIC MAXUS Automotive Co., Ltd., it is required to first ensure that they have no harm to personal safety or safe operation of the vehicle.

This Manual provides technical parameters, service guide and other information of the engine of MAXUS Pure Electric Vehicle series of the 2020 model year, and is not aimed at any particular vehicle model. For any description of the particular vehicle model, buyers should consult the dealer or distributor of SAIC MAXUS Automotive Co., Ltd.

Various "NOTE" to be followed are included in this Manual for minimizing the risks of personal injury during repair or service. Improper repair or service may damage the vehicle or render the vehicle unsafe. But, these "NOTE" are not comprehensive. SAIC MAXUS Automotive Co., Ltd. can not possibly warn of all the potentially hazardous consequences of your failure to follow these instructions.

This Manual is a separate extension of SV63 Service Manual. For the service of the complete vehicle, please see the D60 Service Manual.

No part of this publication may be reproduced, stored in a retrieval system or transmitted, in any form or by any means, electronic, mechanical, photocopying, or otherwise, without the prior written permission of SAIC MAXUS Automotive Co., Ltd.

Error and Recommendation Report

If there is any error found in this Service Manual or any recommendation for the Manual, we are very willing to listen to them.

You can report the recommendation to the After-sales Service Department of SAIC MAXUS Automotive Co., Ltd. via letters or faxes and the contact information is provided as follows:

SAIC MAXUS After-sales Services

No. 2500, Jungong Rd, Shanghai, P.R.China

Zip Code: 200438

When contacting, please prepare the following information:

- ? Your name
- ? Name of the authorized repairer
- ? Phone and fax number of the authorized repairer
- ? Model year and vehicle model
- ? VIN of your car
- ? Description of your concerns
- ? Necessary and relevant information (for example, samples or the number of the pages marked)
- ? Any applicable electronic information of the part identification number

The SAIC MAXUS will answer your question in the following manner:

- ? Hand over your question to the relevant service engineer
- ? Ask the relevant service engineer for the reply
- ? Provide the answer to your question within 10 workdays

We welcome users of SAIC MAXUS automotive to report their concerns to the Customer Support Center of SAIC MAXUS Automotive Co., Ltd. and the contact number is 400-081-2011.

Overview

Because of its pollution-free and zero-emission characteristics, pure electric bus is one of the development directions of urban green transportation and one of the final development directions of new energy vehicle technology.

eDELIVER 9 is a pure electric vehicle with high voltage. When repairing any high-voltage components of the vehicle, it is necessary to remove the service switch on the power battery (see "Service Switch" for details).

Overview

General Information

Major vehicle dimension parameters

Model	SV63C-6610/E610	SV63C-6620/E620
Driving type	Front drive	Front drive
Length, mm	5546	5940
Width, mm	2062	2062
Height, mm	2525	2525
Wheelbase, mm	3366	3760
Front/Rear suspension, mm	1020/1160	1020/1160
Front/Rear track, mm	1734/1756	1734/1756
Minimum turning circle diameter, m	13.4	14.8

Vehicle weight parameters

Model	SV63C-6610/E610		SV63C-6620/E620		
Capacitance of high-voltage battery pack	51.5kWh	72kWh	51.5kWh	72kWh	88.55kWh
Gross vehicle weight, kg	3500	3500	3500	3500	3500
Curb weight of a vehicle, kg	2300	2460	2340	2520	2640
Axle load (Front/rear axle load under gross vehicle weight), kg	1670/1830	1660/1840	1725/1775	1740/1760	1645/1855
Passenger capacity	3	3	3	3	3

Dynamic performance parameters

Item	Parameter	
Max. speed, km/h	100	
Max. reverse speed, km/h	22	
Max. gradeability, %	20	
Accelerating ability, second	Accelerating time from 0 to 50 km/h	7
Driving range, km	WLTP condition	186(51.5kWh high-voltage battery pack model) 236(72kWh high-voltage battery pack model) 296(88.55kWh high-voltage battery pack model)

Drive motor parameter

Model	TZ220XS001
Type	Permanent magnet synchronous motor
Rated speed, r/min	4178
Peak speed, r/min	16000
Rated power, kw	70
Peak power, kw	150
Rated torque, Nm	160
Peak torque, Nm	310

Service braking system parameters

Items	Parameters
Front suspension	Mcperson independent suspension
Rear suspension	Leaf spring non-independent suspension
Leaf spring type	Taper leaf spring
Leaf spring specification (FWD)	80, 100, 110 (N/mm)
Leaf spring specification (RWD)	90, 60/100, 60/110, 60/130, 70/135, 70/160 (N/mm)
Wheel dynamic balance requirement	Residual dynamic unbalance on both sides of wheel assembly shall be less than 10g
Sound free travel of brake pedal	within 10 mm
Reasonable application range of brake friction pair	At least 2mm remaining before wearable material reaching its wear limit

Overview

Recommended fluids

Item	Specification	Capacity
Coolant, L	D-35(-35 °C)	6
Brake fluid, L	Laike 901-4 DOT 4	1
Reducer lubricating fluid, L	Castrol BOT 352B1BEV	0.85 ± 0.05
Washer fluid, L	General low freezing point detergent	4
Air conditioning refrigerant, g	R1234yf	660 ± 20

Wheel and tire

Item	Parameter
Wheel specification	6 1/2J × 16
Tire size	215/75R16C
Gross vehicle weight, kg	≤ 4050
Tire pressure of front/rear wheel (cold condition), bar	4.0/4.75
Tire pressure of spare wheel (cold condition), bar	4.75

Wheel alignment parameters

Item		Parameter
Front Wheels	Camber	0.067° ± 0.5° Absolute value of difference between left and right wheels ≤ 0.5°
	Kingpin Caster	2.47° ± 0.5° Absolute value of difference between left and right wheels ≤ 0.5°
	Toe	0.083° ± 0.083° Absolute value of difference between left and right wheels ≤ 0.1°
	Kingpin Inclination	12.6° ± 0.5° Absolute value of difference between left and right wheels ≤ 0.5°
Rear Wheels	Toe	0° ± 0.417°
	Camber	0° ± 0.5°
	Rear Axle Thrust Angle	0° ± 0.25°

Electric Drive System

Specification

Fastener Specifications

Name	Torque (Nm)
Drain plug	50 ± 5 Nm
Bolt - Water Outlet Pipe Fitting	3 ± 0.3 Nm
Bolt - Electric Parking Actuator	11 ± 1 Nm
Breather plug	10 Nm
Bolt - PEB Assembly	30 ± 5 Nm
Bolt - Shock Pad Retaining	30 ± 5 Nm
Bolt - Three-phase Harness to PEB	9 ± 1 Nm
Bolt - Rotary Transformer Cover	4.5 ± 0.5 Nm
Bolt - Housing	35 Nm
Bolt - Ratchet Shaft	16 ± 1.5 Nm
Bolt - Supporting Plate	16 ± 1.5 Nm
Filler plug	50 ± 5 Nm
Bolt - Main Reduction Gear to Differential Housing	55 Nm+42°
Bolt - Motor Suspension to Suspension Beam	180 ± 10 Nm
Bolt - Drive Motor Suspension to Motor	110 ± 10 Nm
Bolt - Reducer Suspension to Suspension Beam	180 ± 10 Nm
Bolt - Rear Suspension to Subframe	180 ± 10 Nm
Bolt - Reducer Suspension to Motor	110 ± 10 Nm
Bolt - - Rear Suspension Assembly to Motor	110 ± 10 Nm
Bolt - Suspension Beam Assembly	180 ± 10 Nm

Electric Drive System

Parameters

Electric Drive Unit Assembly Parameter Specifications

Name	Parameters
Motor type	Permanent magnet synchronous motor
Operating voltage	235-450 V
Peak power	150 kW
Rated power	70 kW
Rated torque	160 Nm
Peak torque	310 Nm
Rated speed (rpm)	4178 rpm
Peak speed (rpm)	16000 rpm
Speed ratio:	13.066
First level deceleration	3.19
Second level deceleration	4.095
Transmission center distance	185 mm
Maximum input torque	310 Nm

Layout

Exploded View of Controller and Relevant Accessories

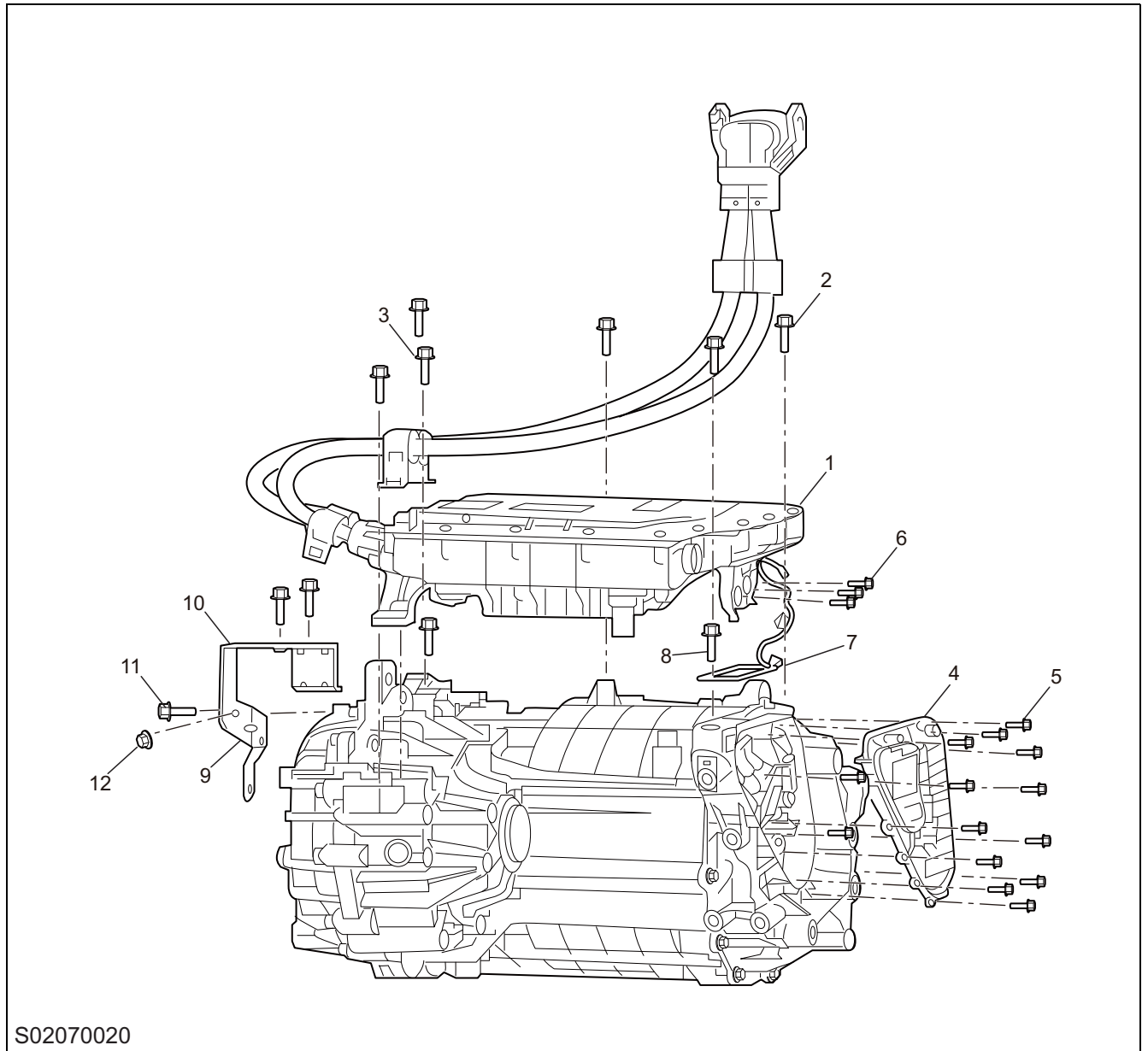

- | | | | |
|---|--|----|---|
| 1 | MCU assembly | 9 | Harness retaining bracket |
| 2 | PEB retaining bolt M8 × 30 | 10 | High-voltage harness bracket |
| 3 | Shock pad bolt M8 × 45 | 11 | High-voltage harness bracket retaining bolt M8 × 20 |
| 4 | Rotary transformer cover | 12 | Hexagon flange bolt M6 × 16 |
| 5 | Rotary transformer cover bolt M5 × 16 | | |
| 6 | Three-phase harness, three-phase harness baffle bolt M6 × 16 | | |
| 7 | PEB motor seal ring | | |
| 8 | PEB closing locating pin | | |

Electric Drive System

Exploded View of Accessories

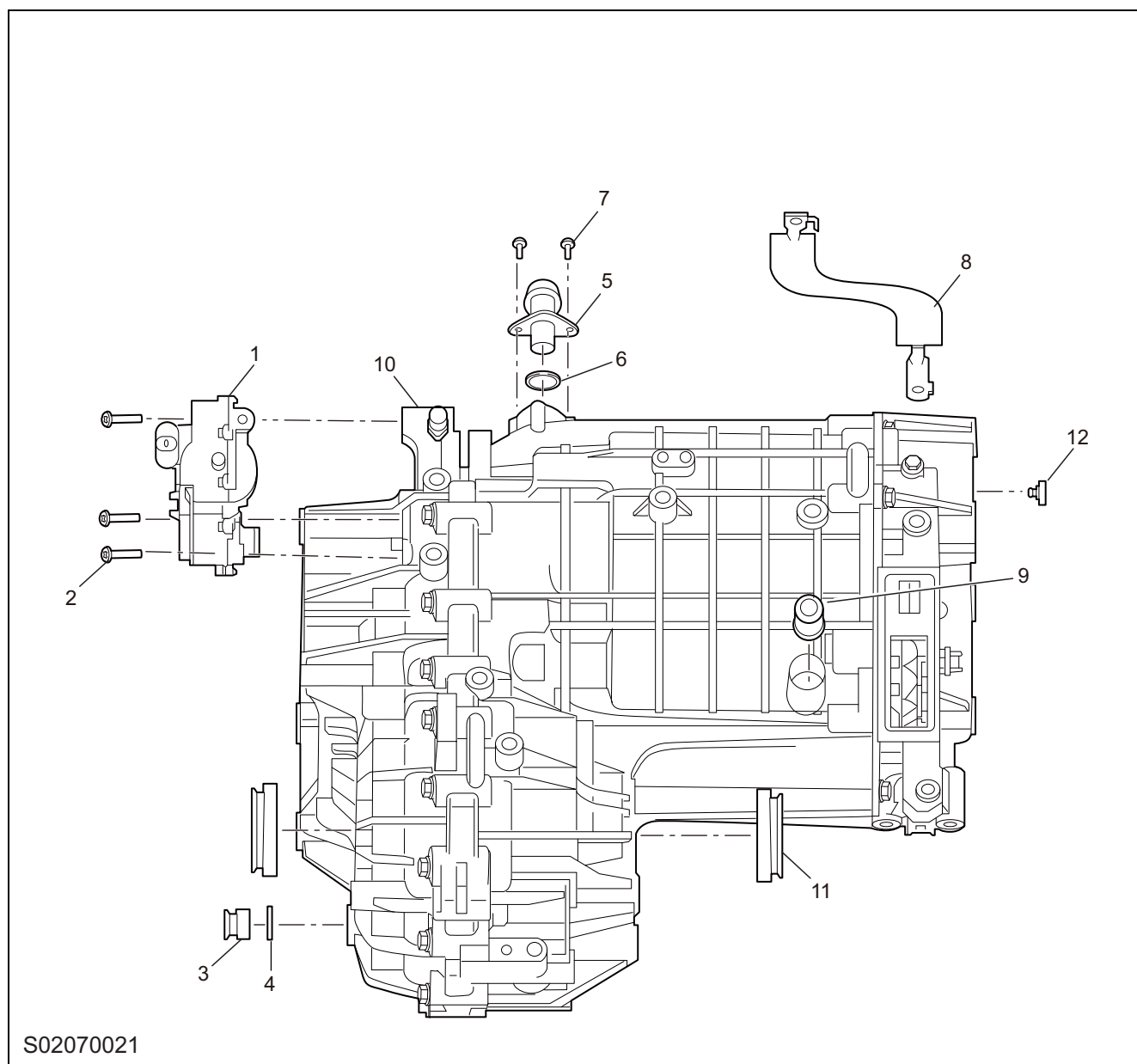

- | | | | |
|----|---|----|-----------------------------------|
| 1 | Electric parking actuator assembly | 11 | Differential oil seal 40 × 66 × 9 |
| 2 | Electric parking actuator assembly bolt M6 × 25 | 12 | Breather valve |
| 3 | Hexagon socket head plug M18 × 1.5 | | |
| 4 | Oil plug gasket ?18 × ?24 × 2 | | |
| 5 | Water pipe fitting | | |
| 6 | Cooling water pipe O-ring | | |
| 7 | Water pipe fitting bolt M4 × 10 | | |
| 8 | Ground wire | | |
| 9 | Water pipe fitting assembly | | |
| 10 | Breather plug assembly | | |

Exploded View of Reducer

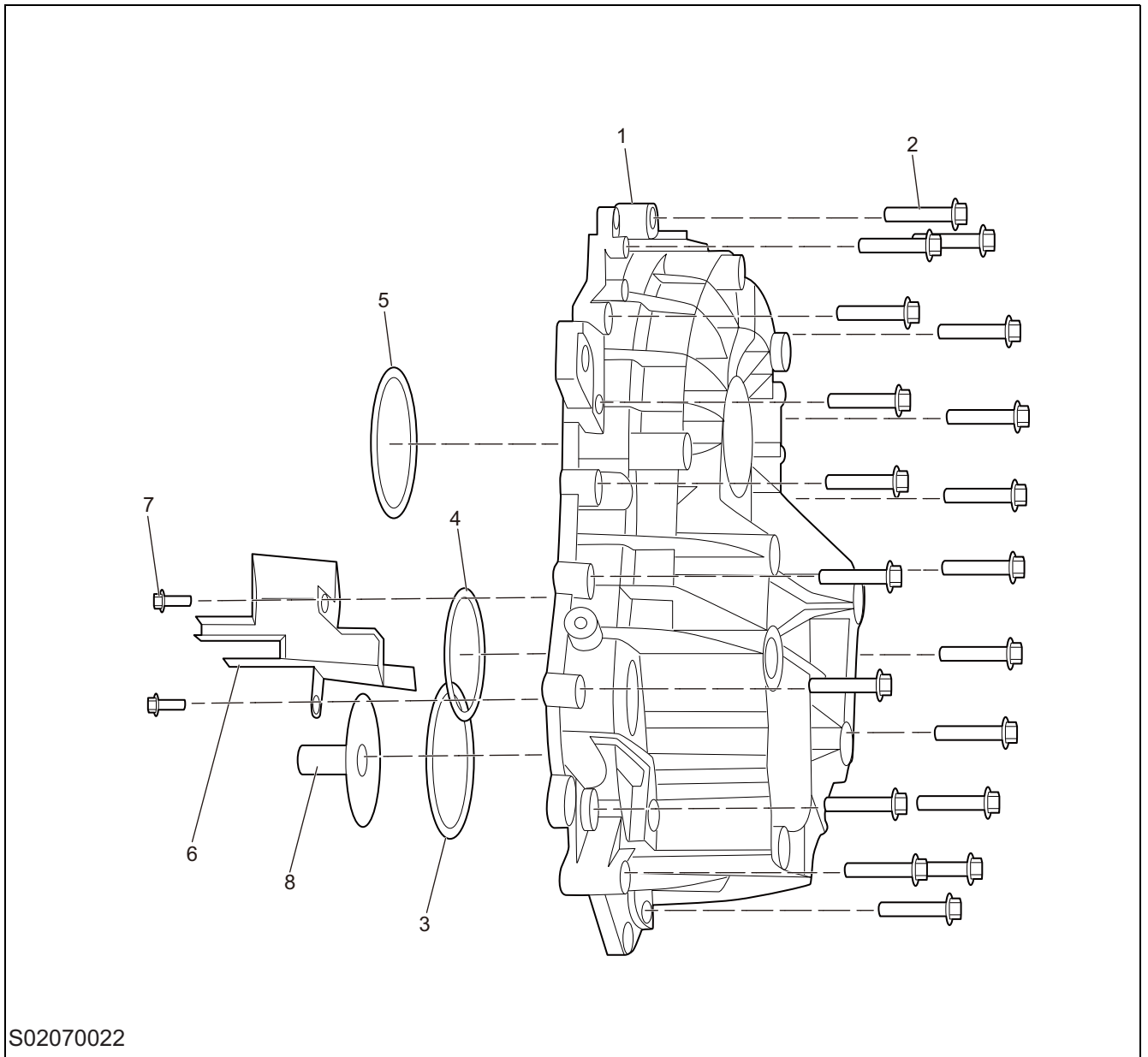

- 1 Reducer rear housing
- 2 Rear housing closing bolt M8 × 40
- 3 Input shaft bearing adjustment gasket
- 4 Intermediate shaft bearing adjustment gasket
- 5 Differential bearing adjustment gasket
- 6 Oil guide groove
- 7 Oil guide groove bolt M6 × 16
- 8 Input shaft oil guide nipple

Electric Drive System

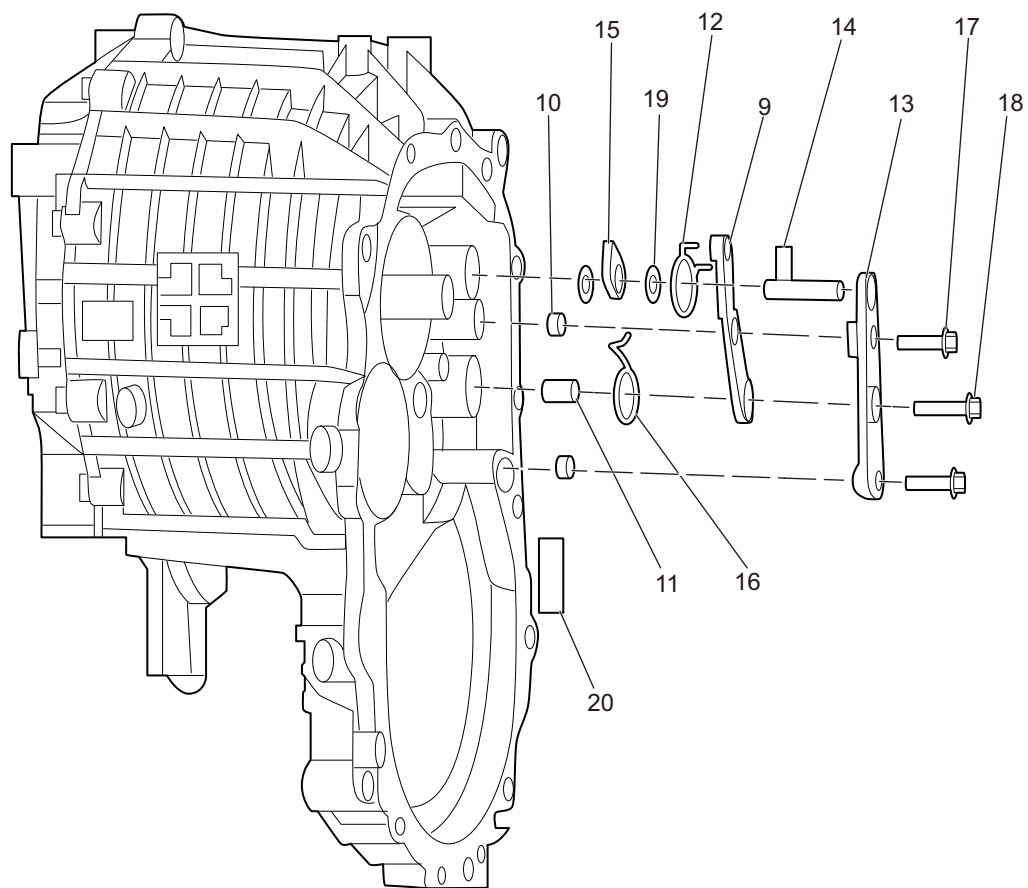

S02070023

- | | | | |
|----|------------------------|----|-------------------------------|
| 9 | Parking ratchet | 15 | Cam |
| 10 | Dowel | 16 | Rotary spring |
| 11 | Pin (hollow) | 17 | Supporting plate bolt M8 × 45 |
| 12 | Torsional spring | 18 | Ratchet shaft bolt M8 × 55 |
| 13 | Parking support | 19 | Gasket |
| 14 | Ratchet rotating shaft | 20 | Magnetic steel |

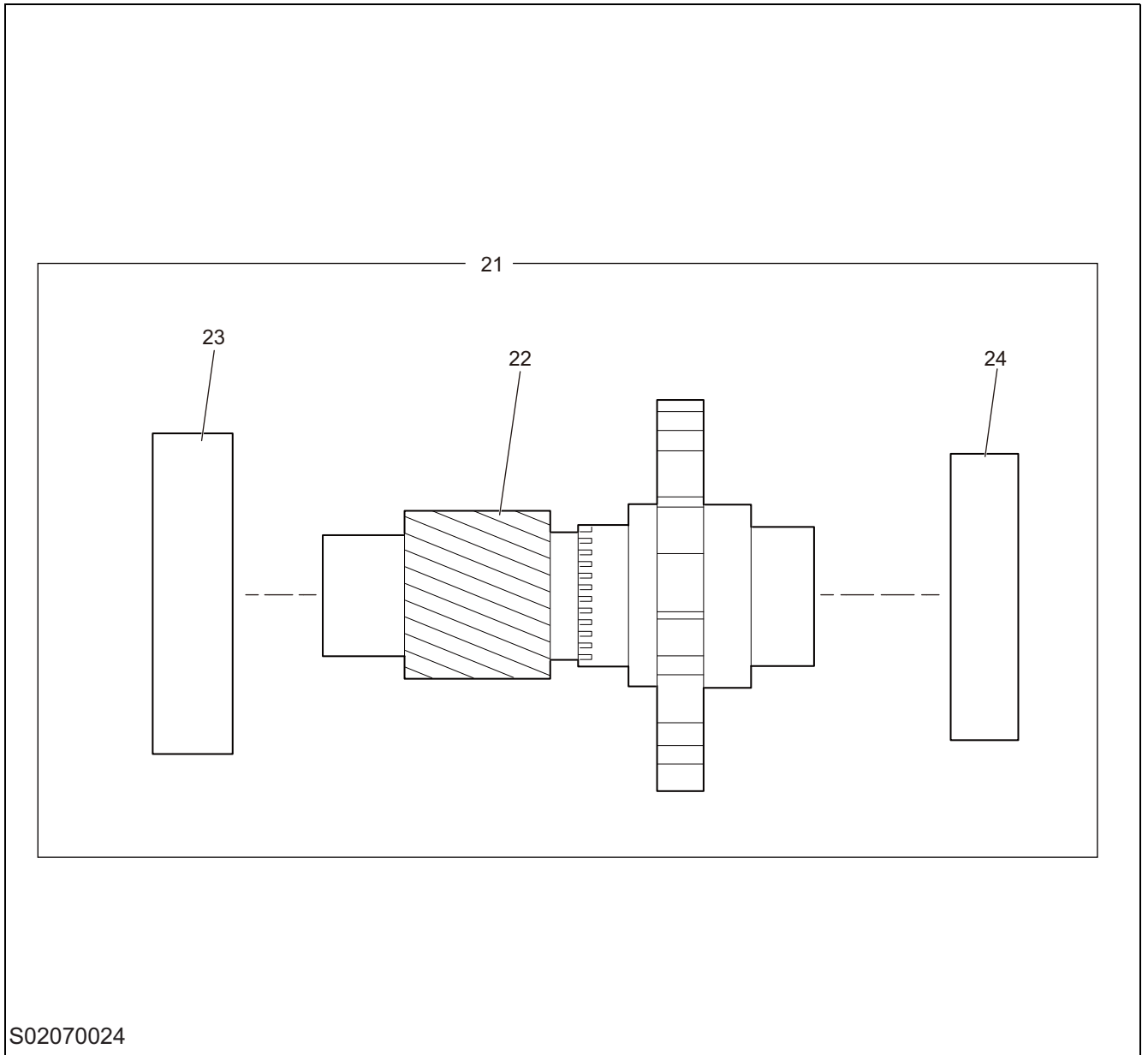

S02070024

- 21 Input shaft assembly
- 22 Input shaft bearing
- 23 Input shaft deep groove ball bearing $40 \times 80 \times 18$
- 24 Input shaft deep groove ball bearing $35 \times 90 \times 23$

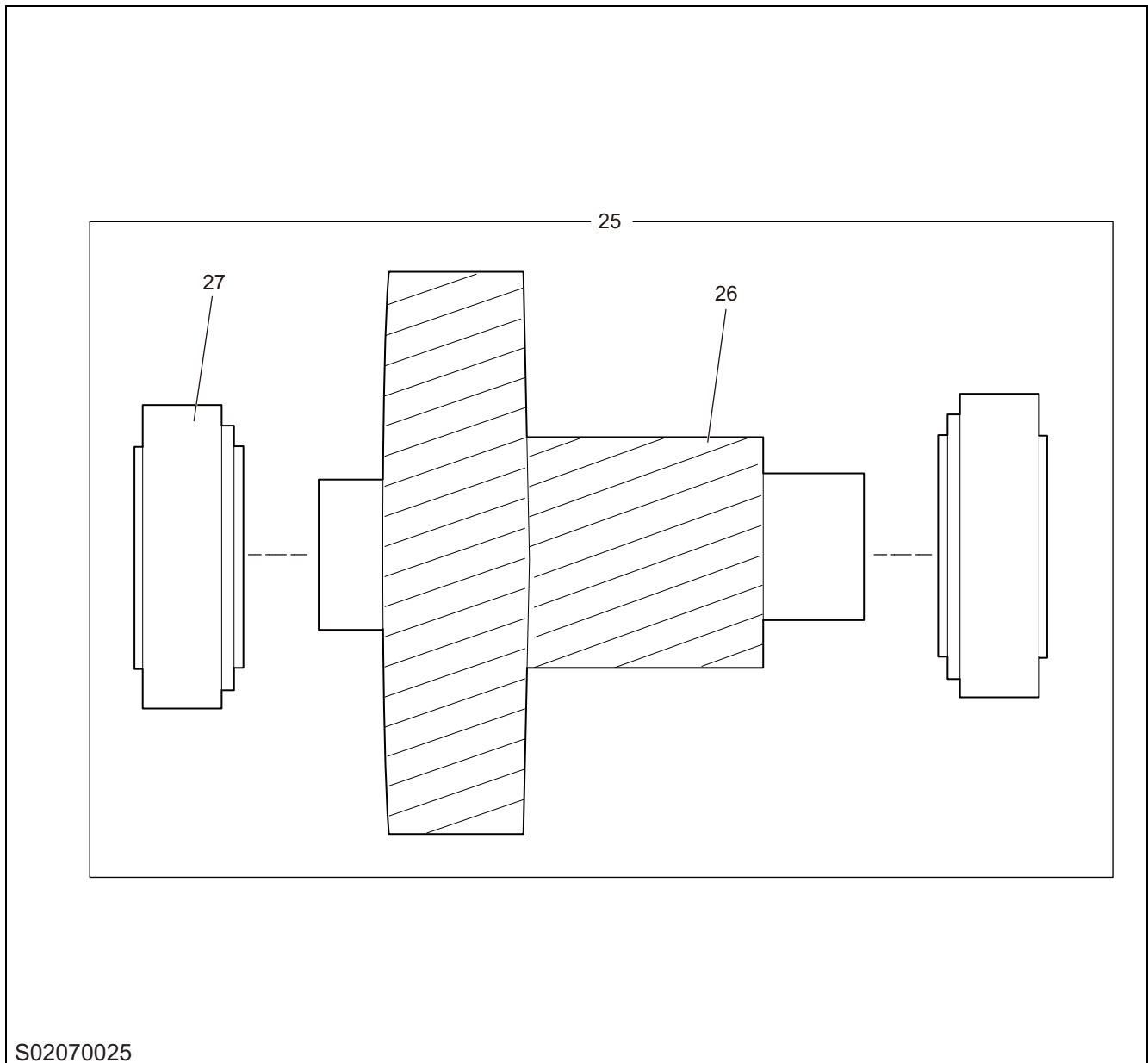

S02070025

25 Intermediate shaft assembly

26 Intermediate shaft welding assembly

27 Intermediate shaft cone bearing $35 \times 72 \times 24.25$

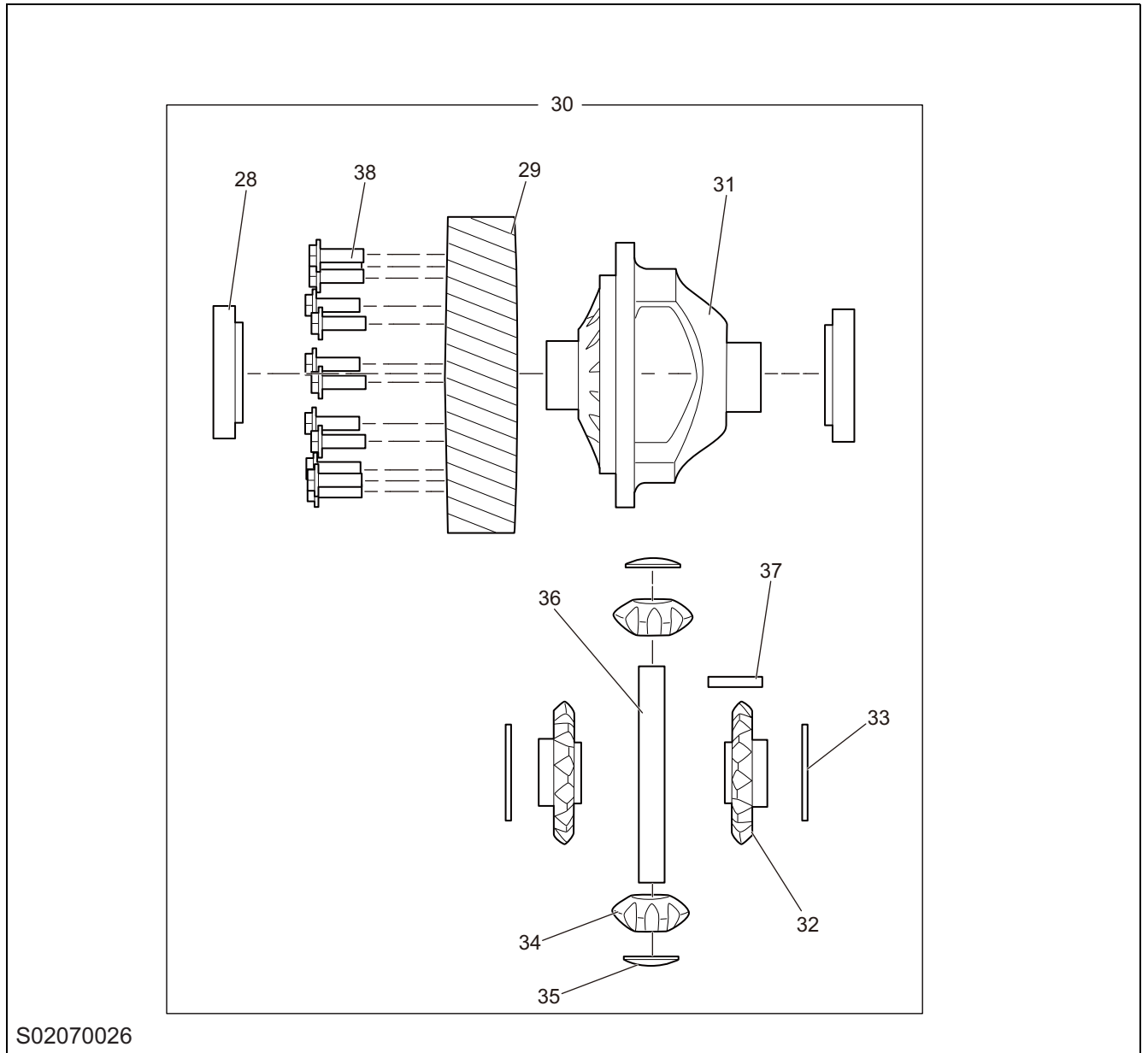

- S02070026
- | | | | |
|----|---|----|-----------------------------------|
| 28 | Differential cone bearing 45 × 85 × 20.75 | 34 | Planet gear |
| 29 | Main reduction gear | 35 | Planet gear gasket |
| 30 | Differential assembly | 36 | Planet shaft |
| 31 | Differential housing | 37 | Coil spring pin D6 |
| 32 | Axle shaft gear | 38 | Main reduction gear bolt M10 × 33 |
| 33 | Axle shaft gear gasket | | |

Electric Drive System

Service Guide

Reducer Oil Drain and Refill

Drain

- 1 Lift the vehicle and place the appropriate container under the transmission.
- 2 Disconnect the sound package strap.

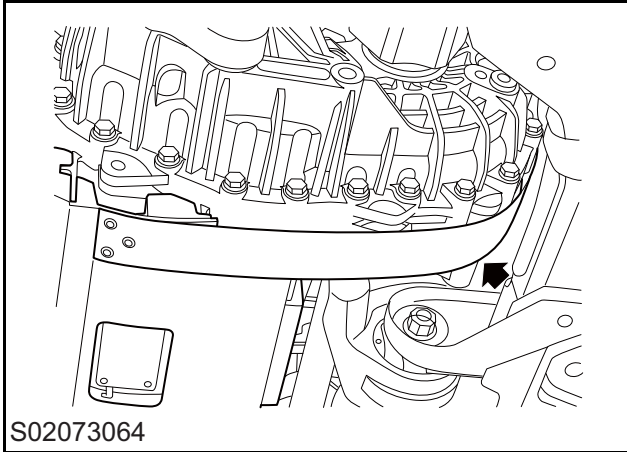

- 3 Clean up the sundries around the oil plug.
- 4 Remove the drain plug (1) and the gasket.

Caution: Oil plug gasket is a disposable part, which shall be discarded after being removed.

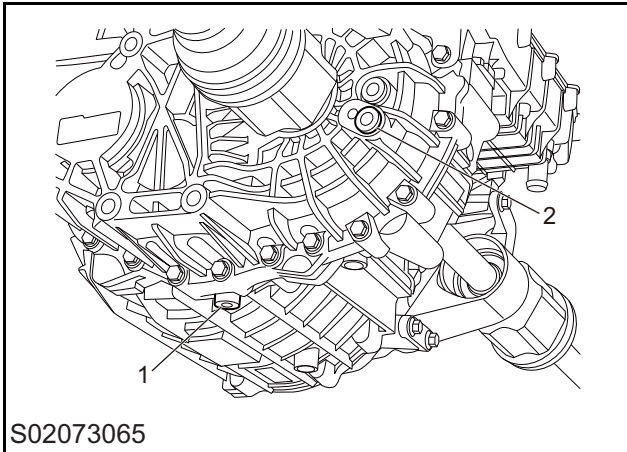

- 5 Drain the transmission oil.

Refill

- 1 Remove the filler plug (2) and the gasket, and discard the gasket.

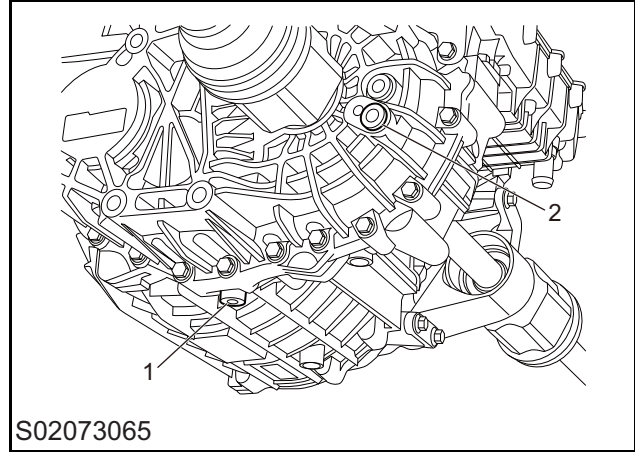

- 2 Clean the oil drain port as well as the oil filler.
- 3 Place the new drain plug gasket onto the drain plug, install and tighten the drain plug to 50 ± 5 Nm, and check the torque.
- 4 Use an appropriate and clean funnel to fill the transmission oil into the transmission through the oil filler until it reaches the specified value.

Caution: The lubricating oil type is Castrol BOT 352B1 gear oil.

- 5 Place a new filler plug gasket onto the filler plug, install and tighten the filler plug to 50 ± 5 Nm, and check the torque.
- 6 Clean oil stains at the filler plug.
- 7 Connect the sound package strap.
- 8 Lower the vehicle to the ground.

Water Outlet Pipe Fitting Replacement

Removal

- 1 Drain the coolant.
- 2 Remove the radiator inlet pipe.
- 3 Remove 2 M4 × 10 bolts (1) at the water outlet pipe fitting.
- 4 Remove the water outlet pipe fitting (2).

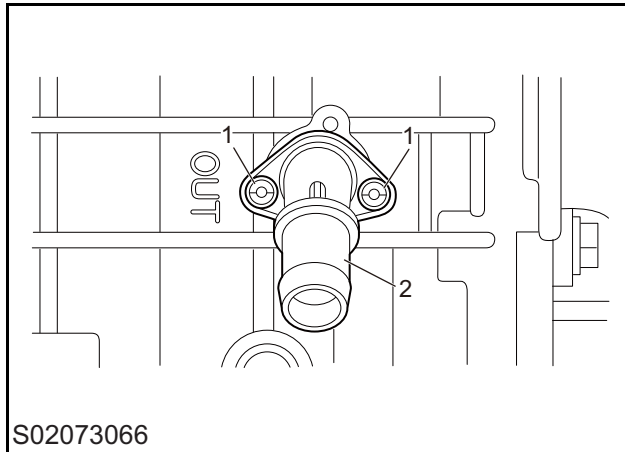

Installation

- 1 Install the water outlet pipe fitting.
- 2 Install the water outlet pipe fitting bolt, tighten it to 3 ± 0.3 Nm, and check the torque.
- 3 Install the radiator inlet pipe.
- 4 Refill the coolant.

Axle Shaft Oil Seal Replacement

Removal

- 1 Drain the reducer oil.
- 2 Remove the axle shaft.
- 3 Clean up the sundries around the axle shaft oil seal.
- 4 Remove and discard the oil seal carefully, take care not to damage the housing oil seal assembly cylinder surface.

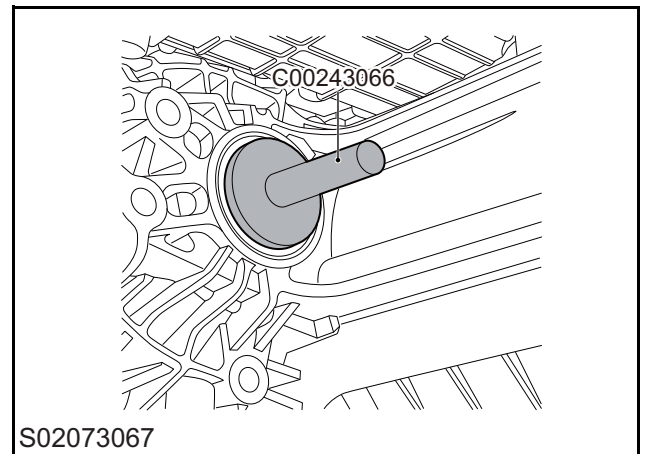

Installation

- 1 Clean the axle shaft oil seal hole.
- Use a new axle shaft oil seal, and knock the axle shaft oil seal in place with the tool C00243066.

Caution: *The flat end of oil seal faces up with no trimming.*

- 2 Install the vehicle axle shaft, and avoid the axle shaft spline from scratching the lip of oil seal.
- 3 Refill the transmission oil.

Electric Drive System

EPP Electric Parking Actuator Replacement

Removal

- 1 Remove the reducer suspension. Refer to "Reducer Suspension Replacement".
- 2 Remove 3 M6 × 25 bolts (1) of the electric parking actuator.
- 3 Remove the electric parking actuator (2).

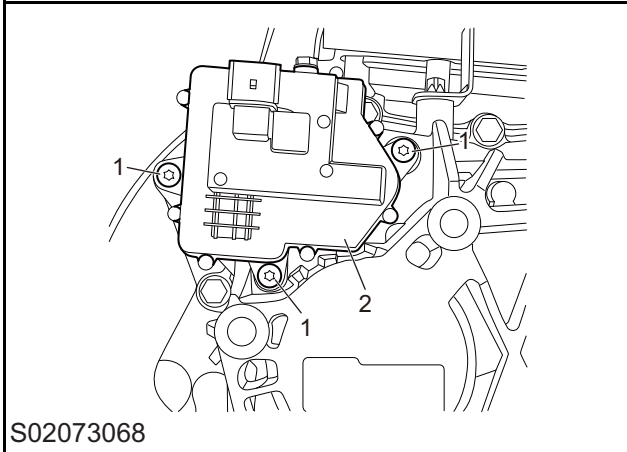

Installation

- 1 Apply oil to the O-ring, and install the electric parking actuator.

Caution: It is required to rotate the ratchet shaft to a certain degree for actuator installation.

Caution: Cooperation at the missing teeth of the actuator and the ratchet shaft.

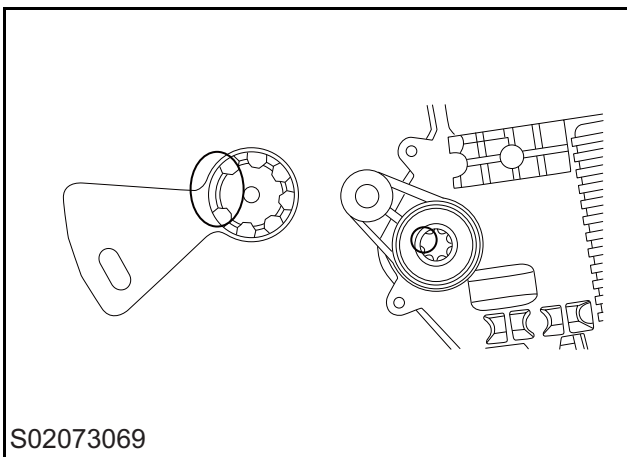

- 2 Tighten 3 M6 × 25 bolts to 11 ± 1 Nm and check the torque.

Caution: Check the O-ring for damage.

- 3 Install the reducer suspension. Refer to "Reducer Suspension Replacement".

Breather Plug Assembly Replacement

Removal

- 1 Remove the reducer suspension. Refer to "Reducer Suspension Replacement".
- 2 Remove the EPP electric parking actuator. Refer to "EPP Electric Parking Actuator Replacement".
- 3 Clean up the sundries around the breather plug assembly and keep it clean.
- 4 Remove the breather plug assembly (1).

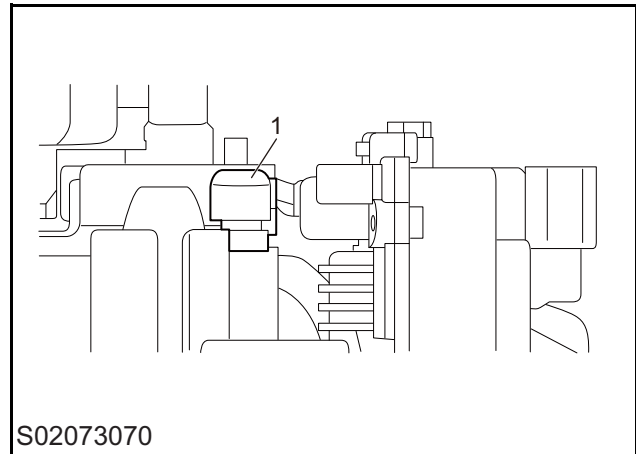

Installation

- 1 Clean up the sundries around the air breather.
- 2 Install a new breather plug assembly, tighten it to 10 Nm, and check the torque.
- 3 Install the EPP electric parking actuator. Refer to "EPP Electric Parking Actuator Replacement".
- 4 Install the reducer suspension. Refer to "Reducer Suspension Replacement".

PEB Assembly Replacement

Removal

- 1 Drain the transmission oil.
- 2 Remove the electric drive assembly.
- 3 Remove 12 M5 × 16 bolts (1) of the rotary transformer cover.
- 4 Remove the rotary transformer cover (2).

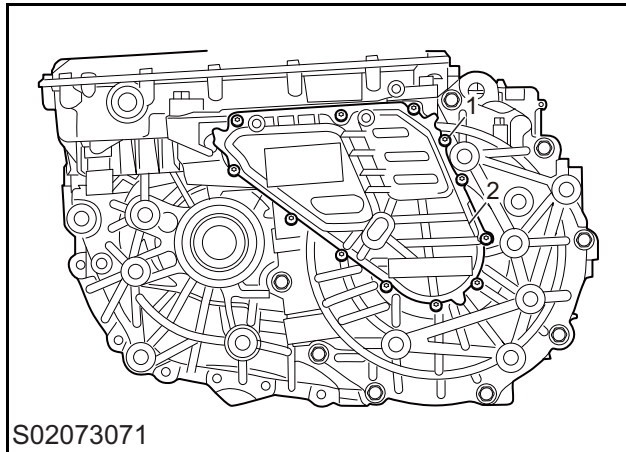

- 5 Disconnect the rotary transformer stator connector.
- 6 Disconnect the temperature sensor connector.
- 7 Remove the harness fastener.
- 8 Remove 3 M6 × 16 connecting bolts (1) of the three-phase harness.

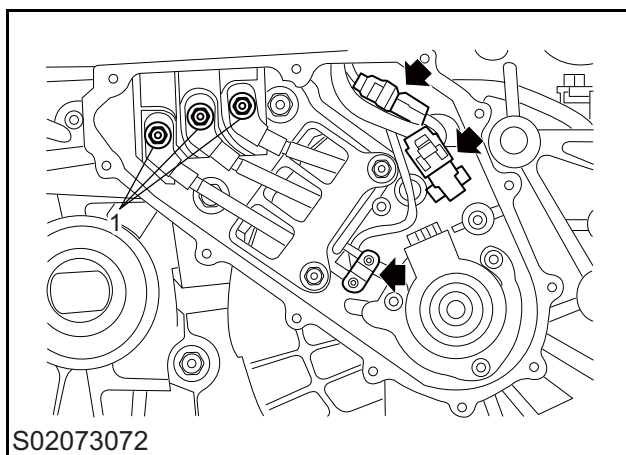

- 9 Remove 1 M8 × 45 retaining bolt (1) of the shock pad.
- 10 Remove 4 M8 × 30 retaining bolts (2) of the PEB.
- 11 Remove the PEB assembly (3) and shock pad.

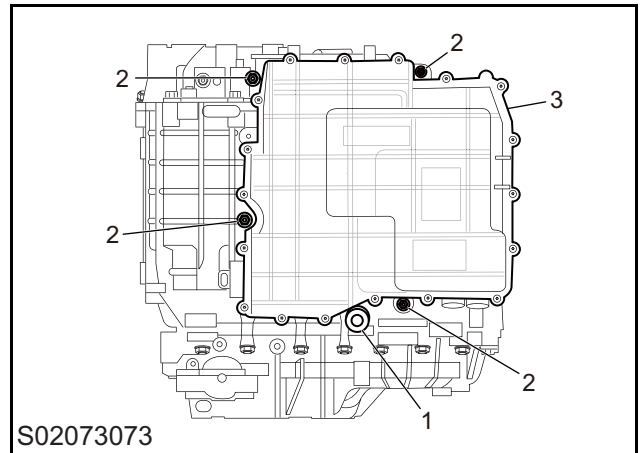

- 12 Remove the PEB motor seal ring.

Caution: Check the seal ring for damage, if damaged, discard it.

Installation

- 1 Install the PEB motor seal ring.
- 2 Install the PEB assembly and shock pad.
- 3 Install the PEB retaining bolts, tighten them to 30 ± 5 Nm, and check the torque.
- 4 Install the shock pad retaining bolts, tighten them to 30 ± 5 Nm, and check the torque.
- 5 Install the bolts connecting the three-phase harness to the PEB, tighten them to 9 ± 1 Nm, and check the torque.

Caution: Three-phase harnesses cannot contact each other, and there is a gap of about 6mm between the harnesses and the housing.

- 6 Connect the temperature sensor connector.
- 7 Connect the rotary transformer stator connector.
- 8 Install the harness fastener.
- 9 Install the rotary transformer cover.
- 10 Install the connecting bolts of the rotary transformer cover, tighten them to 4.5 ± 0.5 Nm, and check the torque.
- 11 Install the electric drive assembly.

Electric Drive System

Rear Housing Assembly Replacement

Removal

- 1 Drain the reducer oil. Refer to "Reducer Oil Drain and Refill".
- 2 Remove the electric drive assembly.
- 3 Remove 19 M8 × 40 flange bolts of the housing.
- 4 Remove the rear housing, clear the sealant on the junction surface between the main housing and the rear housing.
- 5 Remove 2 M6 × 16 bolts (1) of the oil guide groove.
- 6 Remove the oil guide groove (2).
- 7 Remove the intermediate shaft cone bearing outer ring (3) and the differential cone bearing outer ring (4).
- 8 Remove the bearing gasket.
- 9 Remove the input shaft oil guide nipple (5).

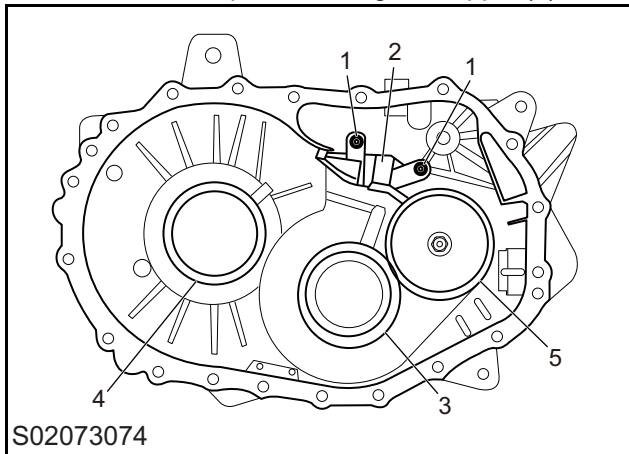

Installation

- 1 Install the input shaft oil guide nipple.
- 2 If the bearing is not replaced, use the original gasket.

Caution: Three gaskets must be put in their original positions.

- 3 If the bearing is replaced, measure and select the gasket. Install a new gasket. Refer to "Selection of Gasket".
- 4 Knock the differential cone bearing outer ring in place.
- 5 Knock the intermediate shaft cone bearing outer ring in place.
- 6 Install the oil guide groove.

- 7 Apply a circle of sealant on the main housing flange.

Caution: The sealant model is Loctite 5900, and it is required that the glue line should be uniform without glue breaking.

- 8 Close the housing; install 19 flange bolts, tighten them to 35 Nm, and check the torque.
- 9 Install the electric drive assembly.
- 10 Refill the reducer oil. Refer to "Reducer Oil Drain and Refill".

Selection of Gasket

- 1 Measure and record the distances a, b and c between the front housing large flange and the end surfaces of the differential cone bearing, intermediate shaft cone bearing and input shaft ball bearing outer rings respectively.

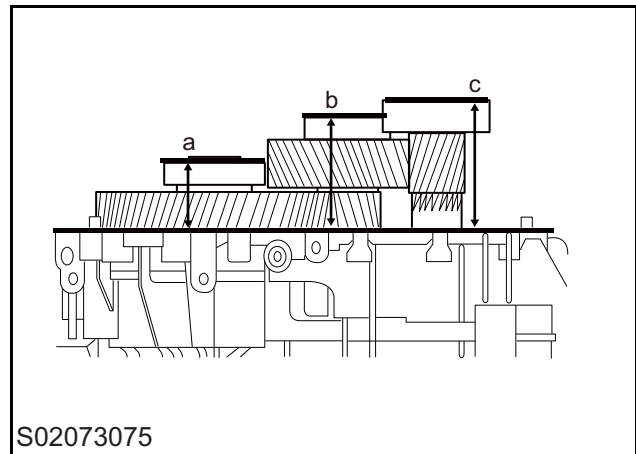

- 2 Measure and record the distances d, e and f between the rear housing large flange and the bottom end surfaces of the differential, intermediate shaft and input shaft bearing holes respectively.

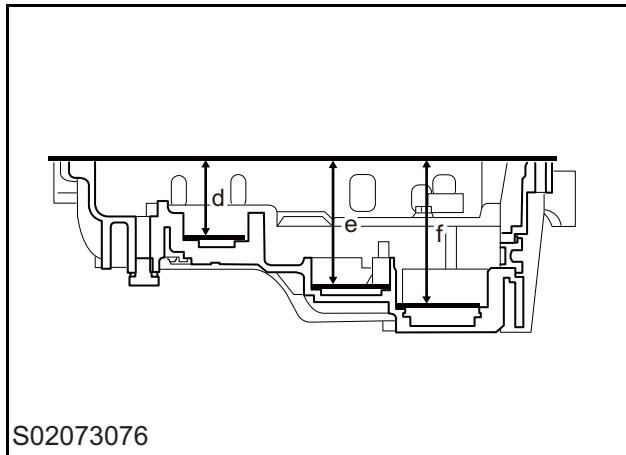

- 3 Calculate the thickness $d-a$ of differential cone bearing adjustment gasket, and select the gasket according to the table below.

Differential		
Minimum value \geq	Maximum value <	Selection of gasket
1.4	1.45	1.55
1.45	1.50	1.60
1.50	1.55	1.65
1.55	1.60	1.70
1.60	1.65	1.75
1.65	1.70	1.80
1.70	1.75	1.85
1.75	1.80	1.90
1.80	1.90	1.95
1.90	1.95	2.00
1.95	2.00	2.05
2.00	2.05	2.10
2.05	2.10	2.15
2.10	2.15	2.20
2.15	2.20	2.25

- 4 Calculate the thickness $e-b$ of intermediate shaft cone bearing adjustment gasket, and select the gasket according to the table below.

Intermediate shaft		
Minimum value \geq	Maximum value <	Selection of gasket
0.95	1.00	1.10
1.00	1.05	1.15
1.05	1.10	1.20
1.10	1.15	1.25
1.15	1.20	1.30
1.20	1.25	1.35
1.25	1.30	1.40
1.30	1.35	1.45
1.35	1.40	1.50
1.40	1.45	1.55
1.45	1.50	1.60
1.50	1.55	1.65
1.55	1.60	1.70
1.60	1.65	1.75
1.65	1.70	1.80

- 5 Calculate the thickness $f-c$ of input shaft cone bearing adjustment gasket, and select the gasket according to the table below.

Input shaft		
Minimum value \geq	Maximum value <	Selection of gasket
1.55	1.65	1.45
1.65	1.75	1.55
1.75	1.85	1.65
1.85	1.95	1.75
1.95	2.05	1.85
2.05	2.15	1.95
2.15	2.25	2.05
2.25	2.35	2.15
2.35	2.45	2.25
2.45	2.55	2.35
2.55	2.65	2.45

Parking Mechanism Replacement

Removal

- 1 Remove the rear housing assembly. Refer to "Rear Housing Assembly Replacement".
- 2 Remove 2 M8 × 45 bolts (1) of the supporting plate.
- 3 Remove 1 M8 × 55 bolt (2) of the ratchet shaft.
- 4 Remove the parking support (3).

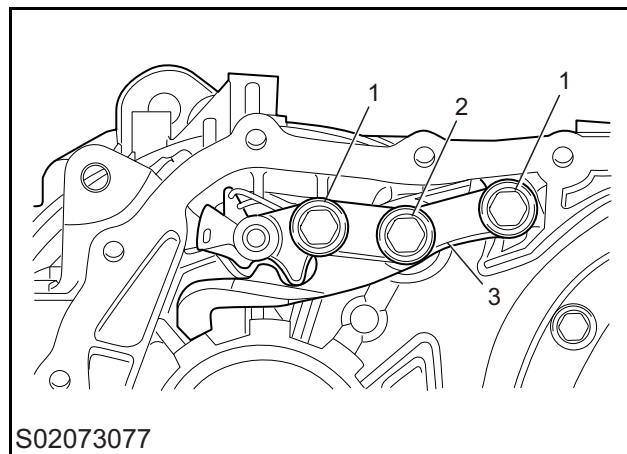

- 5 Remove the rotary spring, cam, two gaskets and ratchet rotating shaft.
- 6 Remove the torsional spring and parking ratchet.

Installation

- 1 Assemble the torsional spring and parking ratchet and install them into the main housing in place.
- 2 Assemble the rotary spring, cam, two gaskets and ratchet rotating shaft and install them into the main housing in place.

Caution: The spline end of the ratchet rotating shaft faces up.

- 3 Install the parking support to the main housing in place.
- 4 Install M8 × 55 bolts of the ratchet shaft into the main housing, tighten them to 16 ± 1.5 Nm and check the torque.
- 5 Install 2 M8 × 45 bolts of the supporting plate into the main housing, tighten them to 16 ± 1.5 Nm and check the torque.
- 6 Install the rear housing assembly. Refer to "Rear Housing Assembly Replacement".

Input Shaft Assembly, Intermediate Shaft Assembly and Differential Assembly Replacement

Removal

- 1 Remove the rear housing assembly. Refer to "Rear Housing Assembly Replacement".
- 2 Remove the magnetic steel.
- 3 Remove the input shaft assembly.
- 4 Remove the intermediate shaft assembly and differential assembly.
- 5 Remove the intermediate shaft cone bearing outer ring (1) and the differential cone bearing outer ring (2) in the main housing.

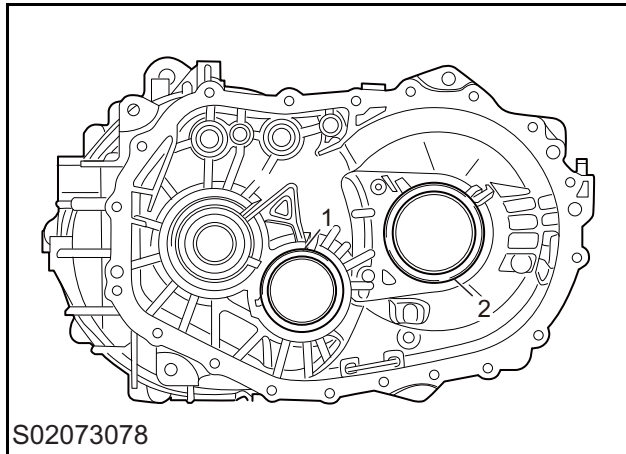

Installation

- 1 Knock the differential cone bearing outer ring in place.
- 2 Knock the intermediate shaft cone bearing outer ring in place.
- 3 Install the input shaft assembly, intermediate shaft assembly and differential assembly.
- 4 Install the magnetic steel.
- 5 Install the rear housing assembly. Refer to "Rear Housing Assembly Replacement".

Input Shaft Assembly Replacement

Removal

- 1 Remove the rear housing assembly. Refer to "Rear Housing Assembly Replacement".
- 2 Remove the input shaft assembly.
- 3 Pull out the deep groove ball bearings on both ends of the input shaft with the puller.

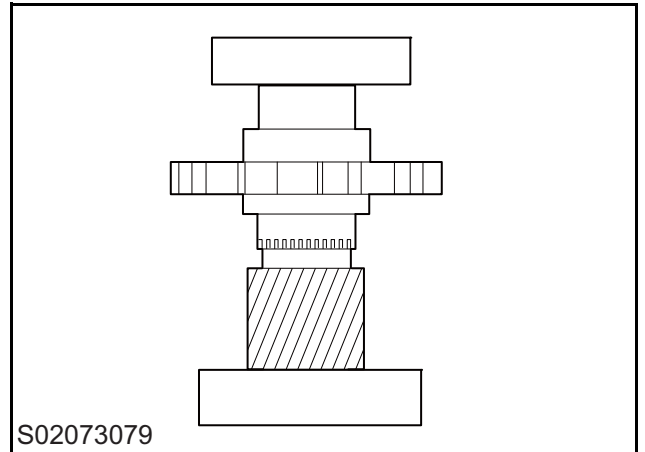

Installation

- 1 Knock the bearings on both ends of the input shaft in place.

Caution: The bearings on both ends are mounted with the brown plastic frames facing outwards.

- 2 Install the rear housing assembly. Refer to "Rear Housing Assembly Replacement".

Electric Drive System

Intermediate Shaft Assembly Replacement

Removal

- 1 Remove the rear housing assembly. Refer to "Rear Housing Assembly Replacement".
- 2 Remove the cone bearing inner rings on both ends of the intermediate shaft with the puller.

S02073080

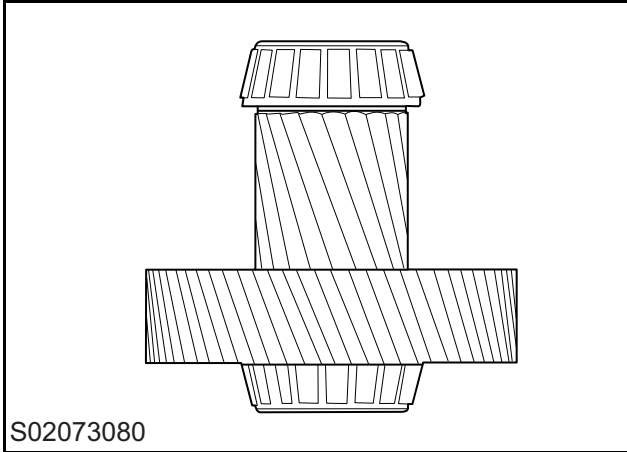

Installation

- 1 Knock two cone bearing inner rings in place.
- 2 Install the rear housing assembly. Refer to "Rear Housing Assembly Replacement".

Differential Assembly Replacement

Removal

- 1 Remove the rear housing assembly. Refer to "Rear Housing Assembly Replacement".
- 2 Remove two differential cone bearing inner rings with the puller.
- 3 Remove 12 M10 × 33 hexagon flange bolts.

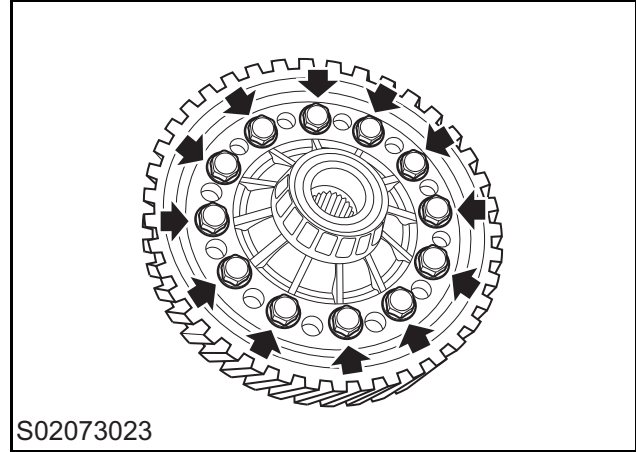

S02073023

- 4 Remove the main reduction gear.
- 5 Remove the planet shaft coil spring pin.
- 6 Remove the planet shaft, and take the planet gear, axle shaft gear and gasket out of the differential.

Installation

- 1 Check the gasket for damage or scratch, if yes, replace the gasket.
- 2 Install the axle shaft gear gasket and the axle shaft gear into the differential housing in place.
- 3 Install the planet gear gasket and the planet gear into the differential housing in place.
- 4 Install the planet shaft into the differential housing in place.

Caution: The planet shaft hole should be aligned with the differential housing hole.

- 5 Install the planet shaft coil spring pin.
- 6 Install the main reduction gear into the differential housing.
- 7 Install 12 M10 × 33 hexagon flange bolts in the order shown, tighten them to 55 Nm+42° , and check the torque.

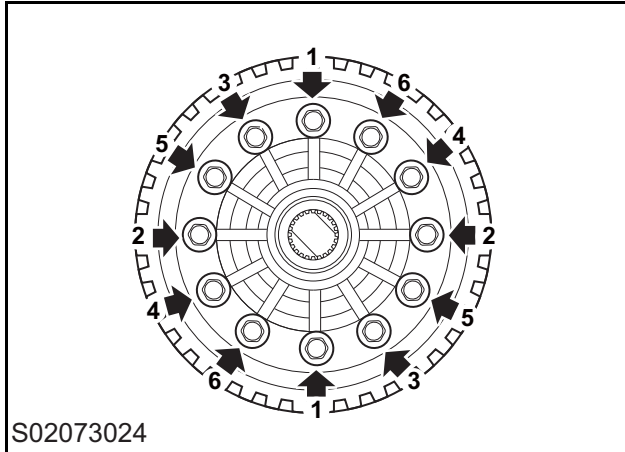

- 8 Knock two cone bearing inner rings in place.
- 9 Install the rear housing assembly. Refer to "Rear Housing Assembly Replacement".

Reducer Suspension Replacement

Removal

- 1 Disconnect the negative battery cable.
- 2 Do not remove the refrigerant pipe, but remove the left A/C compressor. Refer to "A/C Compressor Replacement (Left)".
- 3 Use an appropriate tool to support the drive motor.
- 4 Remove 3 bolts (1) connecting the reducer suspension to the motor.
- 5 Remove the bolt (2) connecting the reducer suspension to the suspension beam.
- 6 Remove the reducer suspension (3).

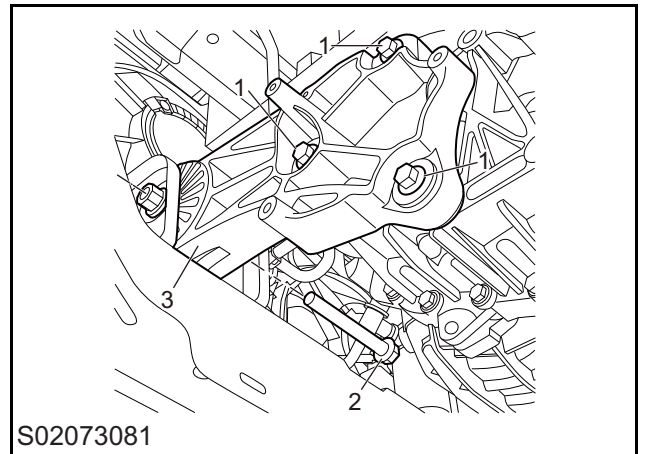

Installation

- 1 Install the reducer suspension.
- 2 Install the bolts connecting the reducer suspension to the suspension beam, tighten them to 180 ± 10 Nm and check the torque.
- 3 Install 3 bolts connecting the reducer suspension to the motor, tighten them to 110 ± 10 Nm and check the torque.
- 4 Install the left A/C compressor. Refer to "A/C Compressor Replacement (Left)".
- 5 Connect the negative battery cable.

Electric Drive System

Drive Motor Suspension Replacement

Removal

- 1 Disconnect the negative battery cable.
- 2 If equipped, do not remove the refrigerant pipe, but remove the right A/C compressor. Refer to "A/C Compressor Replacement (Right)".
- 3 Use an appropriate tool to support the drive motor.
- 4 Remove the bolt (1) fixing the drive motor suspension upper bracket.
- 5 Remove 3 bolts (2) connecting the drive motor suspension to the motor.
- 6 Remove the bolt (3) connecting the drive motor suspension to the suspension beam.
- 7 Remove the drive motor suspension (4).

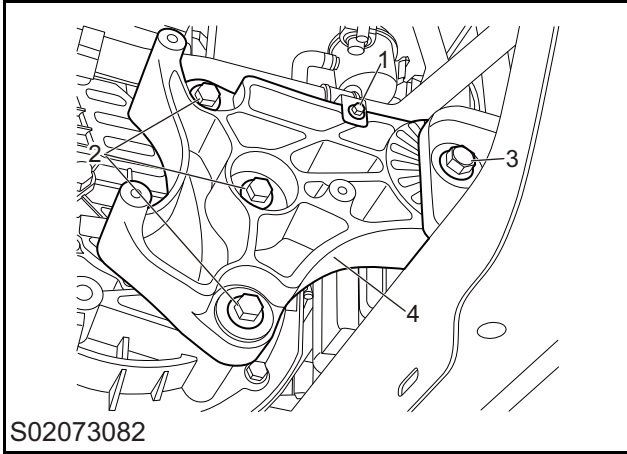

Installation

- 1 Install the drive motor suspension.
- 2 Install the bolts connecting the drive motor suspension to the suspension beam, tighten them to 180 ± 10 Nm and check the torque.
- 3 Install 3 bolts connecting the drive motor suspension to the motor, tighten them to 110 ± 10 Nm and check the torque.
- 4 Install the water pipe bracket bolts, tighten them to 9 ± 1 Nm, and check the torque.
- 5 If equipped, install the right A/C compressor. Refer to "A/C Compressor Replacement (Right)".
- 6 Connect the negative battery cable.

Rear Suspension Assembly Replacement

Removal

- 1 Disconnect the negative battery cable.
- 2 Use an appropriate tool to support the drive motor.
- 3 Remove 3 bolts (1) connecting the rear suspension assembly to the motor.
- 4 Remove the bolt (2) connecting the rear suspension assembly to the subframe.
- 5 Remove the rear suspension assembly (3).

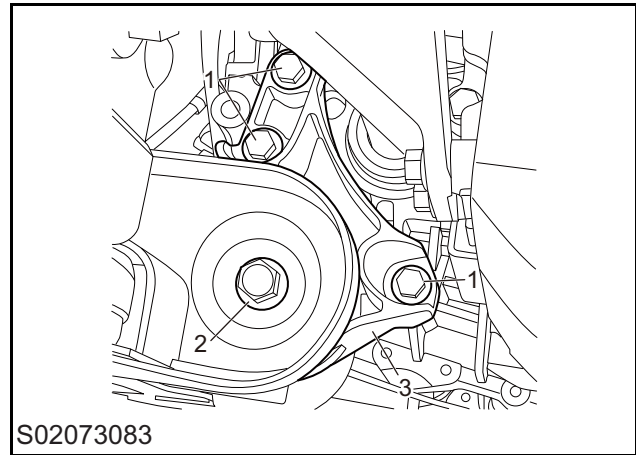

Installation

- 1 Install the rear suspension assembly.
- 2 Install the bolts connecting the rear suspension assembly to the subframe, tighten them to 180 ± 10 Nm and check the torque.
- 3 Install 3 bolts connecting the rear suspension assembly to the motor, tighten them to 110 ± 10 Nm and check the torque.
- 4 Connect the negative battery cable.

Electric Drive System Assembly Replacement

Removal

- 1 Disconnect the negative battery cable.
- 2 Remove the manual service disconnect. Refer to "Manual Service Disconnect Replacement".
- 3 Drain the coolant. Refer to "Coolant Drain".
- 4 Drain the reducer oil. Refer to "Reducer Oil Drain and Refill".
- 5 Remove the left/right axle shaft. Refer to "Axle Shaft Replacement".
- 6 Remove the A/C compressor. Refer to "A/C Compressor Replacement".
- 7 Disconnect the motor controller to charging and distribution unit hose from the motor.

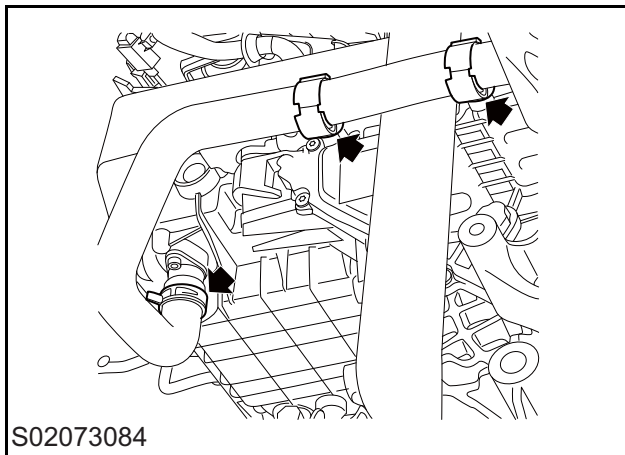

- 8 Disconnect the radiator inlet pipe.

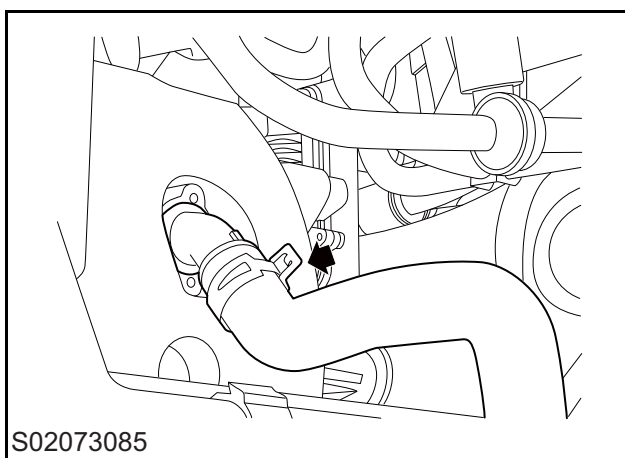

- 9 Remove the high-voltage harness from the charging and distribution unit end.

- 10 Remove the high-voltage harness bracket bolt.

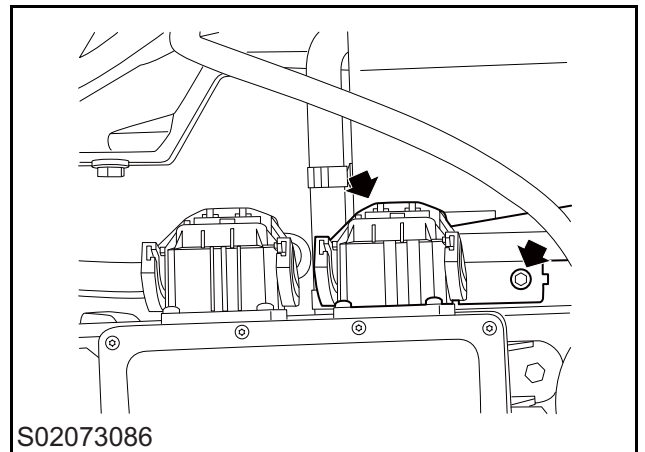

- 11 Disconnect the ground wire.
- 12 The electric drive system assembly will be supported by an appropriate tool.
- 13 Remove the rear suspension assembly. Refer to "Rear Suspension Assembly Replacement".
- 14 Remove the suspension beam assembly bolt (1).
- 15 Remove the suspension beam assembly (2) and the electric drive assembly together.

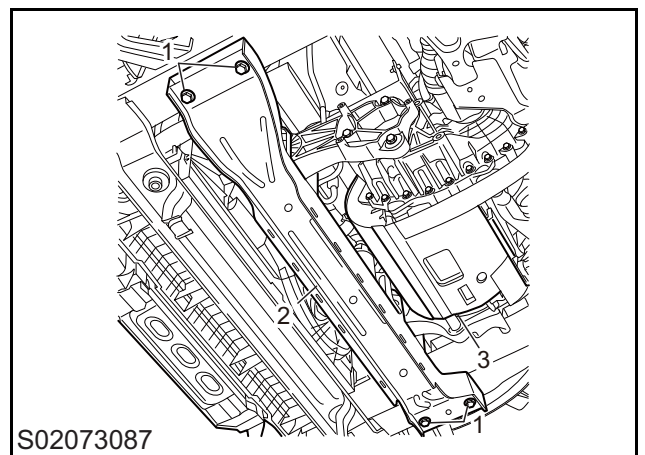

- 16 Remove the drive motor suspension. Refer to "Drive Motor Suspension Replacement".
- 17 Remove the reducer suspension. Refer to "Reducer Suspension Replacement".
- 18 Separate the suspension beam assembly and the electric drive system assembly.

Installation

- 1 Install the electric drive system assembly.

Electric Drive System

- 2 Install the reducer suspension. Refer to "Reducer Suspension Replacement".
- 3 Install the rear suspension. Refer to "Rear Suspension Assembly Replacement".
- 4 Install the drive motor suspension. Refer to "Drive Motor Suspension Replacement".
- 5 Install the suspension beam assembly.
- 6 Install the suspension beam assembly bolts, tighten them to 180 ± 10 Nm and check the torque.
- 7 Install the ground wire.
- 8 Install the high-voltage harness to the charging and distribution unit.
- 9 Install the radiator inlet pipe and the motor controller to charging and distribution unit hose.
- 10 Install the A/C compressor. Refer to "A/C Compressor Replacement".
- 11 Install the left/right axle shaft. Refer to "Axle Shaft Replacement".
- 12 Refill the reducer oil. Refer to "Reducer Oil Drain and Refill".
- 13 Refill the coolant. Refer to "Coolant Drain".
- 14 Install the manual service disconnect. Refer to "Manual Service Disconnect Replacement".
- 15 Connect the negative battery cable.
- 16 Perform the self-learning operation to the electric drive assembly again.

Suspension Beam Assembly Replacement

Removal

- 1 Disconnect the negative battery cable.
- 2 Use an appropriate tool to support the drive motor assembly.
- 3 Remove the bolt connecting the reducer suspension to the suspension beam. Refer to "Reducer Suspension Replacement".
- 4 Remove the bolt connecting the drive motor suspension to the suspension beam. Refer to "Drive Motor Suspension Replacement".
- 5 Remove the suspension beam assembly bolt (1).
- 6 Remove the suspension beam assembly (2).

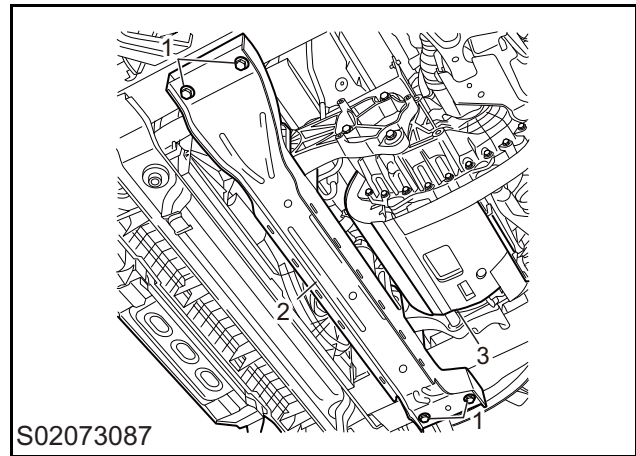

S02073087

Installation

- 1 Install the suspension beam assembly.
- 2 Install the rear suspension beam assembly bolts, tighten them to 180 ± 10 Nm and check the torque.
- 3 Install the bolt connecting the reducer suspension to the suspension beam assembly. Refer to "Reducer Suspension Replacement".
- 4 Install the bolt connecting the drive motor suspension to the suspension beam assembly. Refer to "Drive Motor Suspension Replacement".
- 5 Connect the negative battery cable.

Main Power Switch Replacement

Removal

- 1 Disconnect the negative battery cable.
- 2 Move the driver seat forward.
- 3 Disconnect the main power switch harness.
- 4 Remove the main power switch nut (1).
- 5 Remove the main power switch (2).

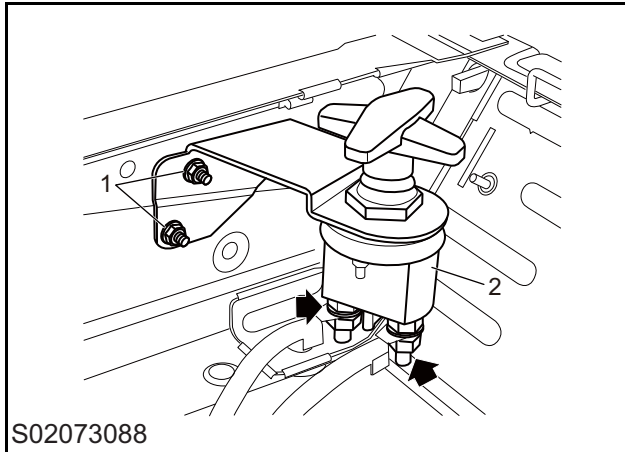

Installation

- 1 Install the main power switch.
- 2 Install the main power switch nuts, tighten them to 9 ± 1 Nm, and check the torque.
- 3 Connect the main power switch harness.
- 4 Restore the driver seat.
- 5 Connect the negative battery cable.

Electric Drive System

Description and Operation

Overview

The three-in-one electric drive assembly integrates the high-speed permanent magnet synchronous motor (with the maximum speed of 16000rpm), motor control power unit (with the power density of 30kW/L), high-speed reducer, electric parking system (integrated electric parking controller).

Reducer Component

The driveline realizes the transmission and deceleration of torque through the engagement of different gears on the input shaft and the intermediate shaft, thus transmitting the motor power to the wheels more effectively. The motor torque is transmitted from the motor to the transmission input shaft through splines. Then the torque is transmitted through the input shaft gear to the intermediate shaft pinion and the main reduction driven gear, and then to the drive shaft. After the vehicle is started and during the driving process, the speed of the vehicle can be altered by changing the speed and direction of the motor in order to realize the shift between drive and reverse gears.

Differential

The differential allows the wheels to rotate at different speeds with the same amount of torque in the center. The pinion integrated with the intermediate shaft engages the main reduction driven gear on the differential assembly. When the intermediate shaft rotates and the wheels move in a straight line, torque is applied to the entire assembly and the planet gear does not rotate. The torque is transmitted to the wheel through the drive shaft. When cornering, the inner wheels travel a short distance at a slow speed, causing the planet gears to rotate, while the outer axle shaft gears provide the outer wheels with a faster speed.

Special Tools

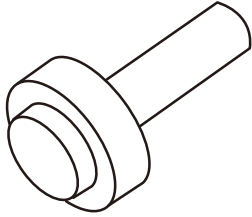
SN.	Tool Number/ Description	Illustration
1	C00243066 Differential Oil Seal Assembly Tool	 C00243066

Power and Control System

Specification

Fastener Specifications

Name	Torque (Nm)
Bolt - Power Battery to Longitudinal Beam	110 ± 10 Nm
Bolt - Power Battery to Adapter Bracket	110 ± 10 Nm
Bolt - Adapter Bracket to Vehicle Body	110 ± 10 Nm
Bolt - Charging and Distribution Unit	22 ± 2 Nm
Nut - Charging and Distribution Unit	22 ± 2 Nm
Bolt - Battery Block	22 ± 2 Nm
Bolt - Battery Bracket	22 ± 2 Nm
Bolt - Complete Vehicle Controller Bracket	9 ± 1 Nm
Nut - Complete Vehicle Controller Bracket	9 ± 1 Nm
Bolt - Complete Vehicle Controller	5 ± 1 Nm
Nut - Power Battery High-voltage Output Harness Assembly Bracket	9 ± 1 Nm
Bolt - Power Battery High-voltage Output Harness Assembly Bracket	9 ± 1 Nm
Bolt - Low-speed Alarm Module	9 ± 1 Nm

Power and Control System

Layout

Power and Control System Layout

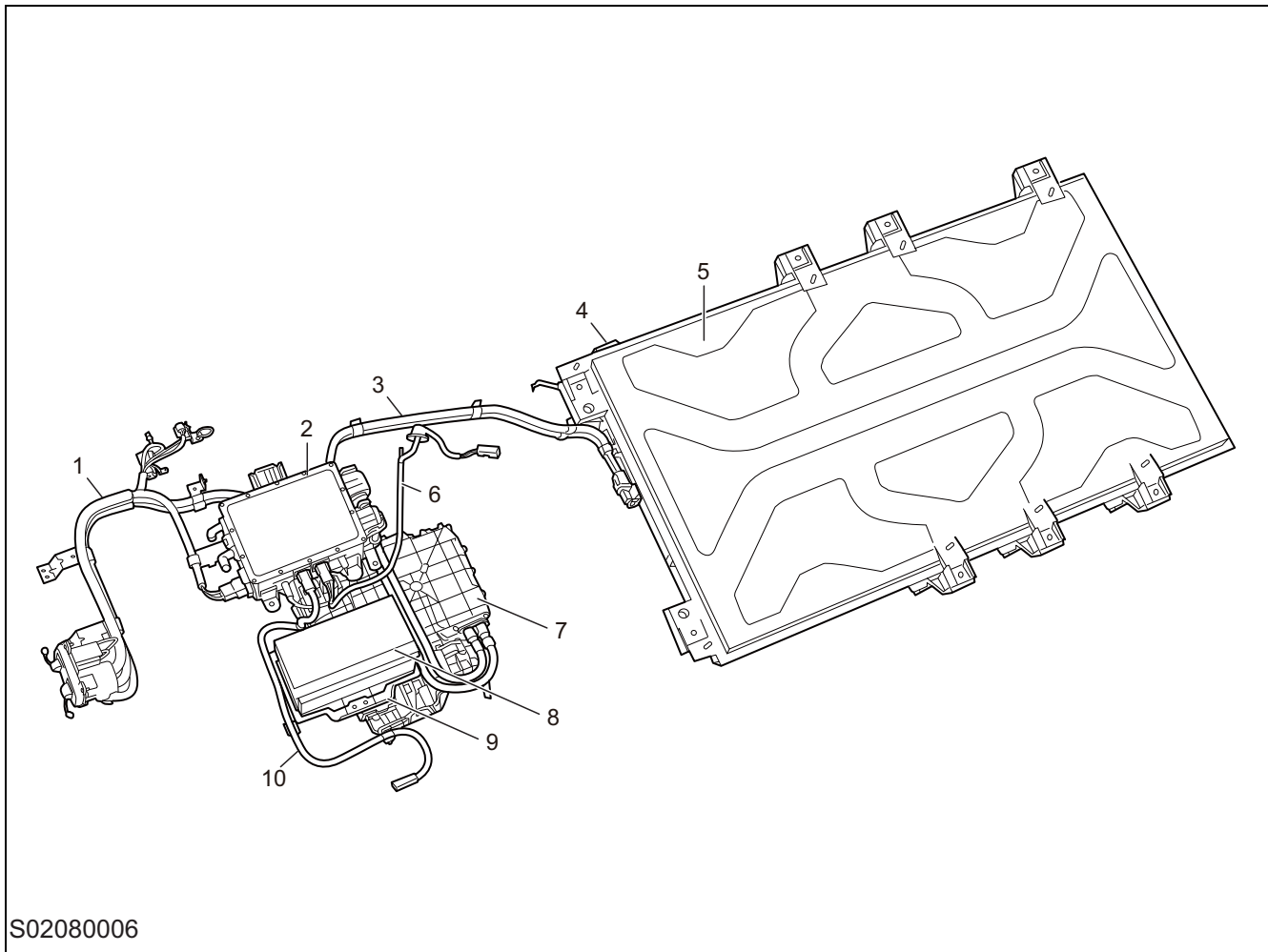

- 1 Integral AC/DC charging harness assembly
- 2 Charging and distribution unit
- 3 Power battery high-voltage output harness assembly
- 4 Service switch
- 5 Power battery
- 6 Front electric heater high-voltage harness assembly
- 7 Three-in-one electric drive assembly
- 8 Battery
- 9 Battery bracket
- 10 Front air compressor harness assembly

Service Guide

Power Battery Replacement (88.55Kwh Battery)

Removal

- 1 Turn off the key power of the complete vehicle and wait for 3-5 minutes.
- 2 Remove the service switch. Refer to "Service Switch Replacement".
- 3 Lift the vehicle to the appropriate height.
- 4 Disconnect the low-voltage harness connector from the battery.
- 5 Disconnect the power battery high-voltage output harness.
- 6 Disconnect the battery ground wire.
- 7 Use an appropriate bracket to support the weight of the rear battery.
- 8 Remove 10 bolts (1) connecting the battery to the adapter bracket.
- 9 Remove 4 bolts (2) connecting the rear battery to the longitudinal beam.
- 10 And lower the bracket, remove the power battery (3).
- 11 If necessary, remove the adapter bracket to vehicle body bolt (4) and the adapter bracket.

- 3 Install 10 bolts connecting the battery to the adapter bracket, tighten them to 110 ± 10 Nm and check the torque.
- 4 Install 4 bolts connecting the rear battery to the longitudinal beam, tighten them to 110 ± 10 Nm and check the torque.
- 5 Connect the power battery high-voltage output harness.
- 6 Connect the battery ground wire.
- 7 Connect the harness connector to the battery.
- 8 Install the service switch. Refer to "Service Switch Replacement".
- 9 Perform the self-learning operation to the power battery again.

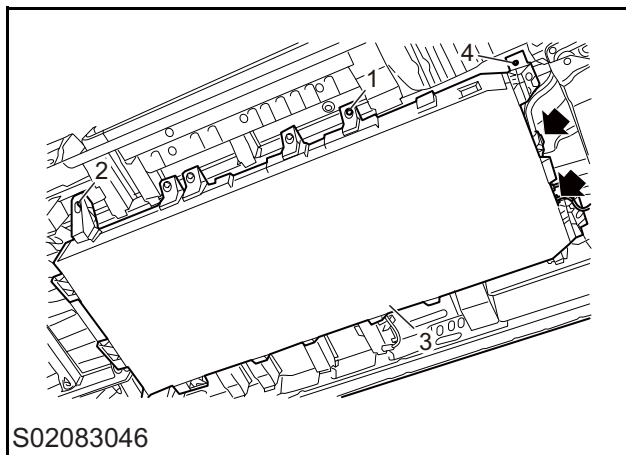

Installation

- 1 If necessary, install the bolts connecting the adapter bracket to the vehicle body, tighten them to 110 ± 10 Nm, and check the torque.
- 2 Lift the bracket and install the power battery.

Power and Control System

Power Battery Replacement (51.5Kwh/72Kwh Battery)

Removal

- 1 Turn off the key power of the complete vehicle and wait for 3-5 minutes.
- 2 Remove the service switch. Refer to "Service Switch Replacement".
- 3 Lift the vehicle to the appropriate height.
- 4 Disconnect the low-voltage harness connector from the battery.
- 5 Disconnect the power battery high-voltage output harness.
- 6 Disconnect the battery ground wire.
- 7 Use an appropriate bracket to support the weight of the rear battery.
- 8 Remove 8 bolts (1) connecting the battery to the adapter bracket.
- 9 And lower the bracket, remove the power battery (2).
- 10 If necessary, remove the adapter bracket to vehicle body bolt (3) and the adapter bracket.

- 5 Connect the battery ground wire.
- 6 Connect the harness connector to the battery.
- 7 Install the service switch. Refer to "Service Switch Replacement".
- 8 Perform the self-learning operation to the power battery again.

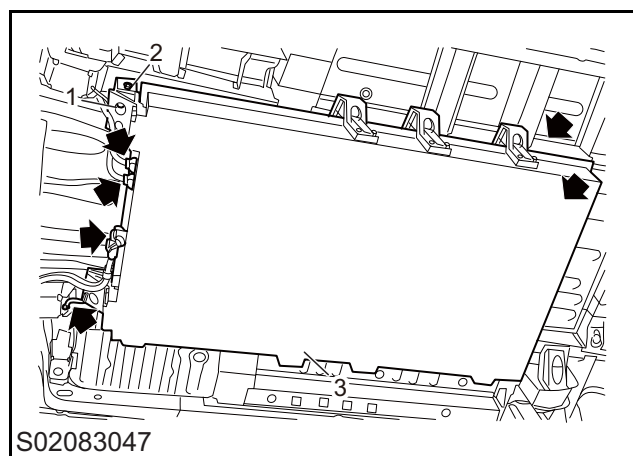

Installation

- 1 If necessary, install the bolts connecting the adapter bracket to the vehicle body, tighten them to 110 ± 10 Nm, and check the torque.
- 2 Lift the bracket and install the power battery.
- 3 Install 8 bolts connecting the battery to the adapter bracket, tighten them to 110 ± 10 Nm and check the torque.
- 4 Connect the power battery high-voltage output harness.

Service Switch Replacement (Type I)

Removal

- 1 Disconnect the negative battery cable.
- 2 Press the lock button on the black handle.

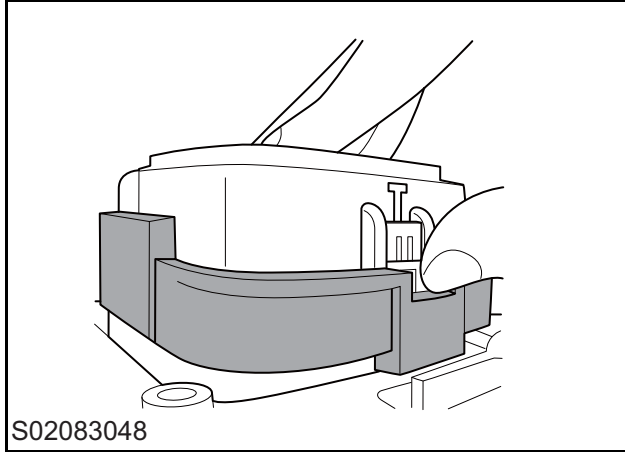

- 3 Pull out the lock button on the black handle upwards.

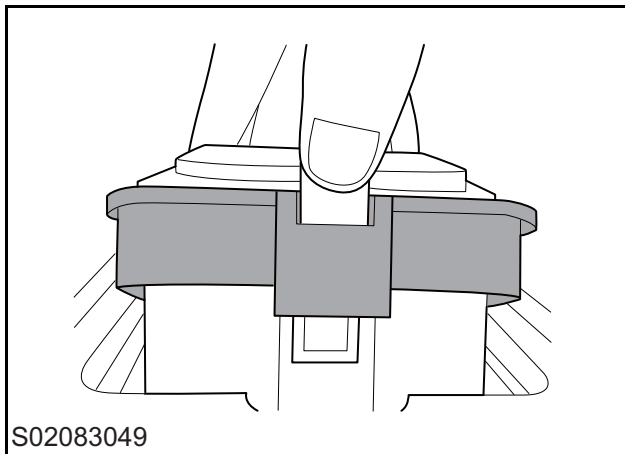

- 4 And rotate the black handle to about 60° and stop.

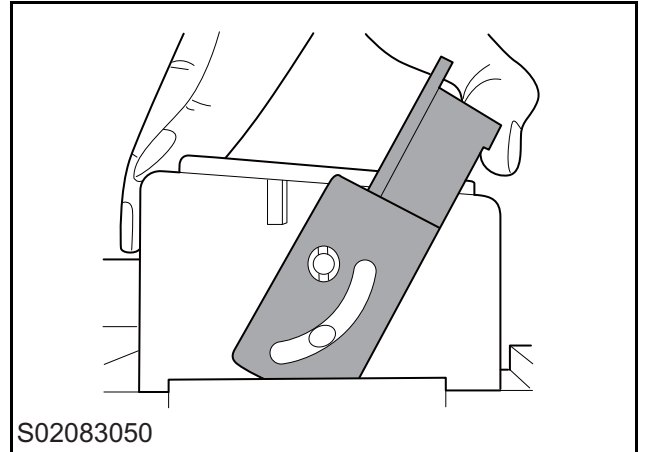

- 5 Press the elastic button inwards.

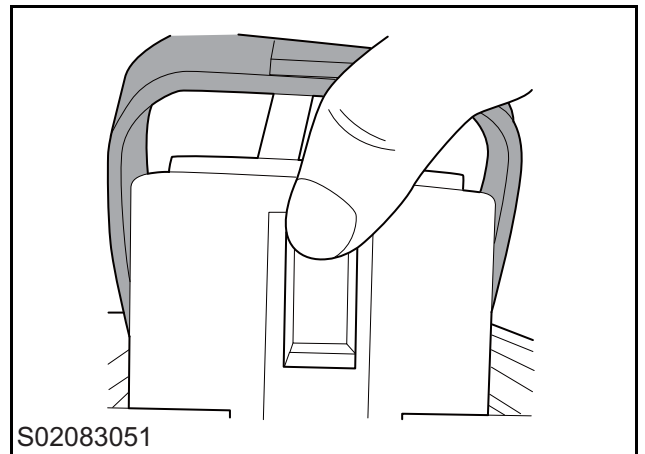

- 6 Rotate the handle to 90° , and pull out the plug.

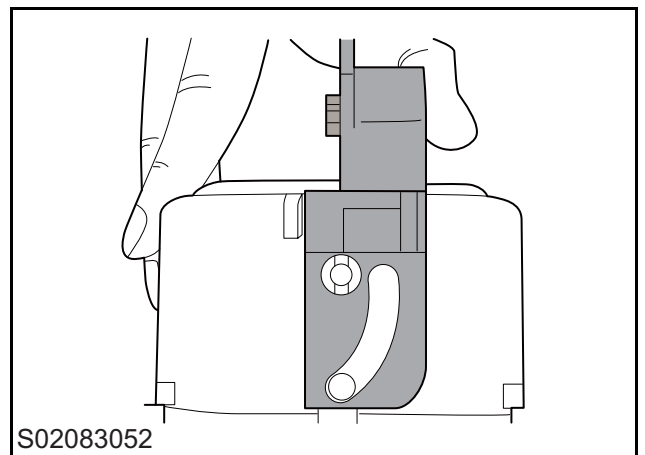

Installation

- 1 Insert the service switch.
- 2 Rotate the black handle to horizontal state until a "click" sound of hook is heard.
- 3 Press the lock button on the black handle.
- 4 Connect the negative battery cable

Power and Control System

Service Switch Replacement (Type II)

Removal

- 1 Disconnect the negative battery cable.
- 2 Unlock the locking mechanism.

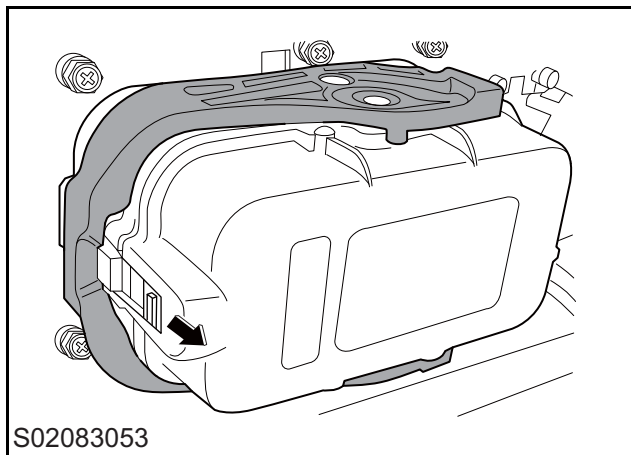

- 3 Press the lock button and rotate the handle to 90°.

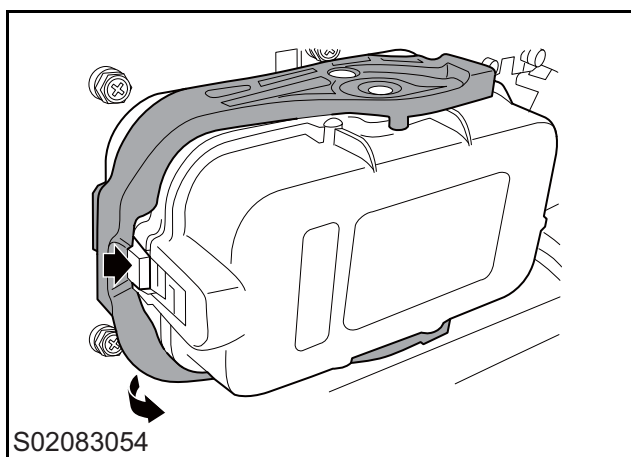

- 4 Pull outward again to remove the service switch (1) from the socket.

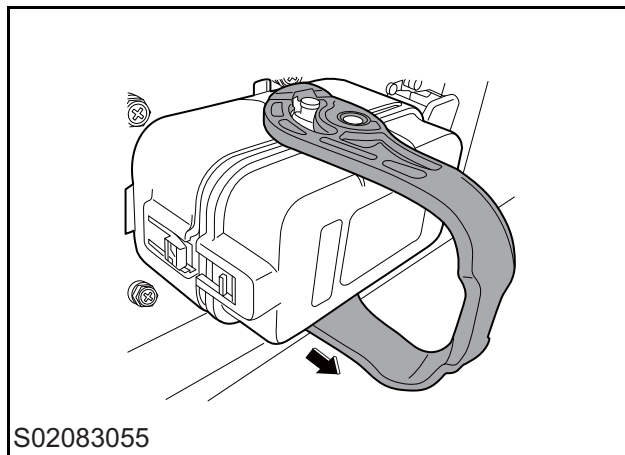

Installation

- 1 Insert the service switch.
- 2 Rotate the black handle to horizontal state until a "click" sound of hook is heard.
- 3 Press the lock button to lock the handle.
- 4 Connect the negative battery cable.

Sound Absorbing Cover Replacement

Removal

- 1 Remove the sound absorbing cover clip (1).
- 2 Remove the sound absorbing cover (2).

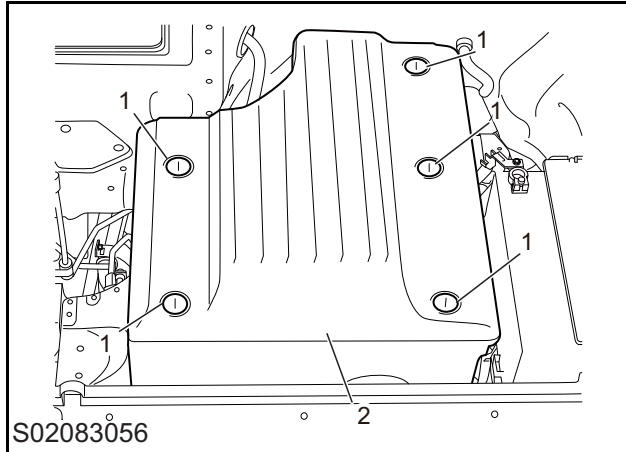

Installation

- 1 Install the sound absorbing cover.
- 2 Install the sound absorbing cover clip.

Charging and Distribution Unit Replacement

Removal

- 1 Turn off the key power of the complete vehicle and wait for 3-5 minutes.
- 2 Disconnect the negative battery cable.
- 3 Remove the service switch. Refer to "Service Switch Replacement".
- 4 Remove the sound absorbing cover. Refer to "Sound Absorbing Cover Replacement".
- 5 Drain the cooling system coolant.
- 6 Disconnect the motor controller harness.
- 7 Disconnect the power battery high-voltage harness.
- 8 Disconnect the front air compressor high-voltage harness from the front electric heater.
- 9 If equipped, disconnect the rear air compressor high-voltage harness from the rear electric heater.
- 10 Disconnect the engine compartment harness.
- 11 Disconnect the DC charging harness.
- 12 Disconnect the water inlet and outlet pipes.
- 13 Disconnect the ground wire from the charging and distribution unit harness connector.
- 14 Remove the charging and distribution unit bolt (1) and nut (2).
- 15 Remove the sound absorbing cover mounting bracket (3).
- 16 Remove the charging and distribution unit (4).

Power and Control System

S02083057

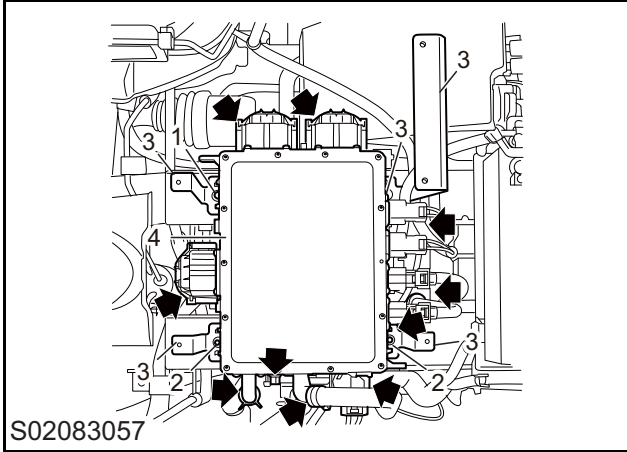

Installation

- 1 Install the charging and distribution unit.
- 2 Install the charging and distribution unit bolt and nut, tighten them to 22 ± 2 Nm, and check the torque.
- 3 Install the charging and distribution unit low-voltage harness connector and ground wire.
- 4 Connect the water inlet and outlet pipes.
- 5 Install all the high-voltage harnesses connected to the charging and distribution unit.
- 6 Install the sound absorbing cover. Refer to "Sound Absorbing Cover Replacement".
- 7 Refill the cooling system coolant.
- 8 Install the service switch. Refer to "Service Switch Replacement".
- 9 Connect the negative battery cable.

Battery Replacement

Removal

- 1 Turn off the key power of the complete vehicle and wait for 3-5 minutes.
- 2 Remove the service switch. Refer to "Service Switch Replacement".
- 3 Open the bonnet.
- 4 Remove the positive/negative battery cable.
- 5 Remove 2 battery block bolts (1).
- 6 Remove the battery block (2).
- 7 Remove the battery(3).

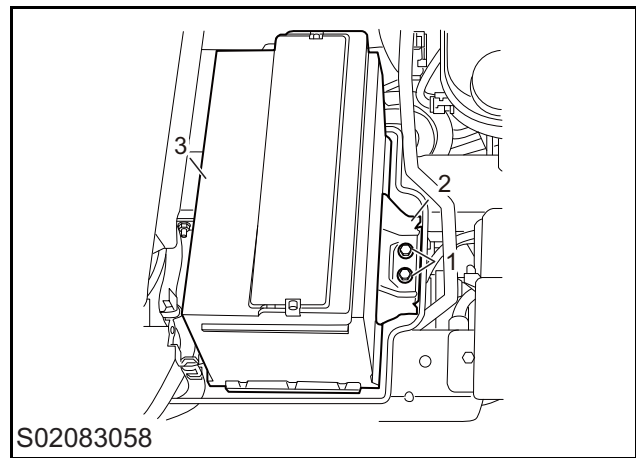

Installation

- 1 Install the battery.
- 2 Install the battery block.
- 3 Install the battery block bolts, tighten them to 22 ± 2 Nm and check the torque.
- 4 Install the bonnet.
- 5 Install the service switch. Refer to "Service Switch Replacement".
- 6 Connect the positive and negative battery cables.

Battery Bracket Replacement

Removal

- 1 Turn off the key power of the complete vehicle and wait for 3-5 minutes.
- 2 Remove the service switch. Refer to "Service Switch Replacement".
- 3 Open the bonnet.
- 4 Remove the battery. Refer to "Battery Replacement".
- 5 Remove 4 battery bracket bolts (1).
- 6 Remove the battery bracket (2).

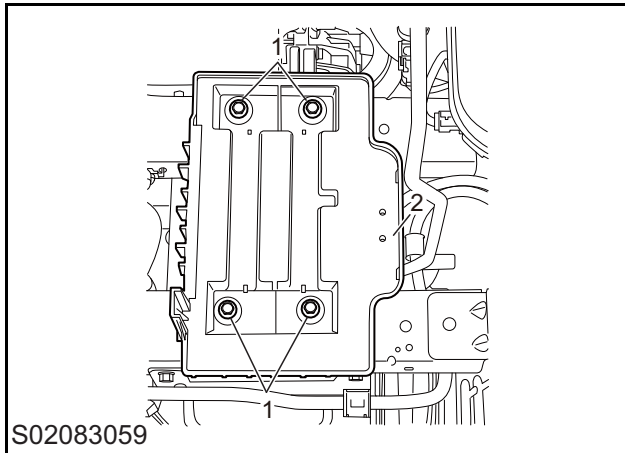

Installation

- 1 Install the battery bracket.
- 2 Install 4 battery bracket bolts, tighten them to 22 ± 2 Nm and check the torque.
- 3 Install the complete vehicle controller. Refer to "Complete Vehicle Controller Replacement".
- 4 Install the battery. Refer to "Battery Replacement".
- 5 Install the service switch. Refer to "Service Switch Replacement".

Positive Battery Harness Replacement

Removal

- 1 Turn off the key power of the complete vehicle and wait for 3-5 minutes.
- 2 Disconnect the negative battery cable.
- 3 Remove the service switch. Refer to "Service Switch Replacement".
- 4 Disconnect the positive battery harness from the steering gear.
- 5 Disconnect the positive battery harness from the air compressor.
- 6 Disconnect the positive battery harness from the water pump.
- 7 Disconnect the nut (1) connecting the positive battery harness to the vehicle body.
- 8 Disconnect the positive battery harness from the vehicle body.

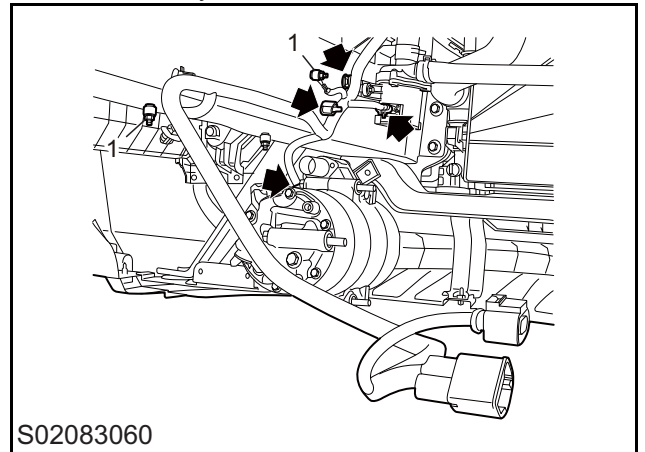

- 9 Disconnect the positive battery harness from the charging and distribution unit.
- 10 Disconnect the positive battery harness from the sensor.
- 11 Disconnect the positive battery harness from the battery.
- 12 Disconnect the positive battery harness from the fuse box.
- 13 Remove the positive battery harness (1).

Power and Control System

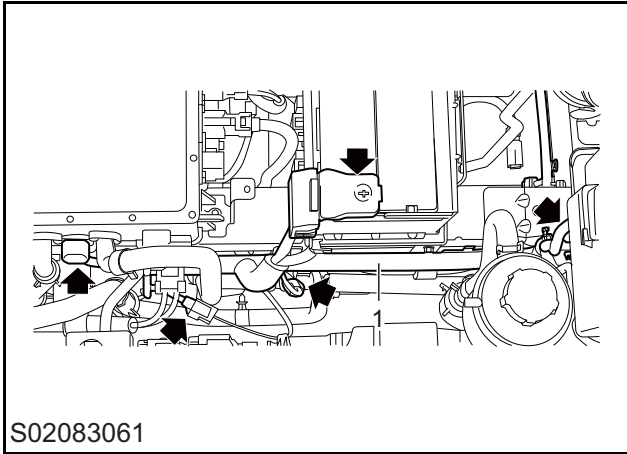

Installation

- 1 Install the positive battery harness.
- 2 Connect the positive battery harness to the fuse box.
- 3 Connect the positive battery harness to the charging and distribution unit.
- 4 Connect the positive battery harness to the battery.
- 5 Install the nut connecting the positive battery harness to the vehicle body and tighten it.
- 6 Connect the positive battery harness to the steering gear, air compressor and water pump.
- 7 Install the sound absorbing cover. Refer to "Sound Absorbing Cover Replacement".
- 8 Install the service switch. Refer to "Service Switch Replacement".
- 9 Connect the negative battery cable.

Negative Battery Harness Replacement

Removal

- 1 Turn off the key power of the complete vehicle and wait for 3-5 minutes.
- 2 Remove the nut (1) connecting the negative battery harness to the battery.
- 3 Remove the service switch. Refer to "Service Switch Replacement".
- 4 Remove the bolt (2) connecting the negative battery harness to the charging and distribution unit.
- 5 Disconnect the negative battery harness from the charging and distribution unit.

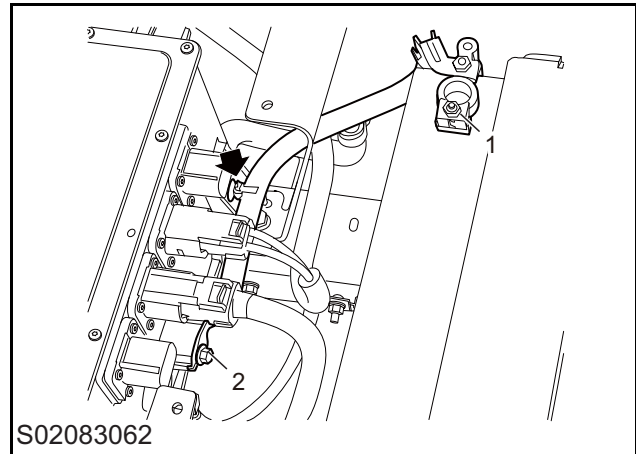

- 6 Raise the vehicle.
- 7 Remove the nut (2) connecting the negative battery harness to the vehicle body.
- 8 Disconnect the negative battery harness from the vehicle body.
- 9 Remove the negative battery harness (3).

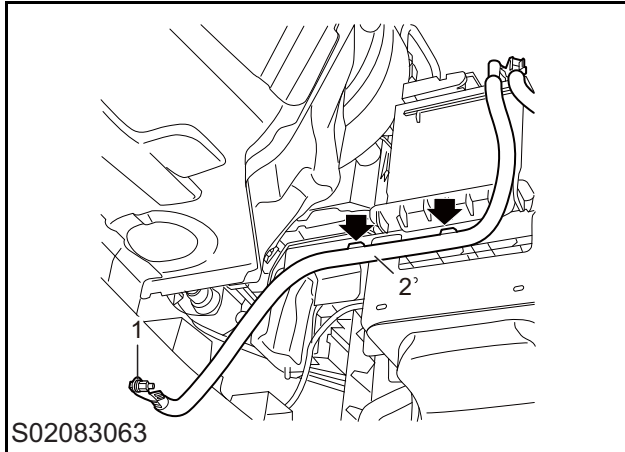

Installation

- 1 Install the negative battery harness.
- 2 Connect the negative battery harness to the vehicle body.
- 3 Install the nut connecting the negative battery harness to the vehicle body and tighten it.
- 4 Install the bolt connecting the negative battery harness to the charging and distribution unit and tighten it.
- 5 Install the sound absorbing cover. Refer to "Sound Absorbing Cover Replacement".
- 6 Install the service switch. Refer to "Service Switch Replacement".
- 7 Install the nut connecting the negative battery harness to the battery and tighten it.

Integral AC/DC Charging Harness Assembly Replacement

Removal

- 1 Turn off the key power of the complete vehicle and wait for 3-5 minutes.
- 2 Disconnect the negative battery cable.
- 3 Remove the service switch. Refer to "Service Switch Replacement".
- 4 Remove the radiator grille assembly.
- 5 Remove the sound absorbing cover. Refer to "Sound Absorbing Cover Replacement".
- 6 Remove the DC charging harness assembly to mounting plate bolt (1).
- 7 Remove the DC charging harness assembly to mounting plate nut (2).
- 8 Remove the DC charging harness assembly bracket bolt (3).

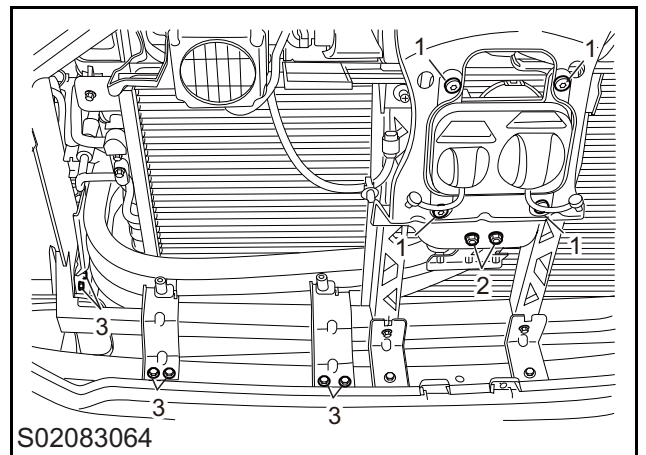

- 9 Disconnect the high-voltage harness from the charging and distribution unit.
- 10 Disconnect the low-voltage harness from the integral AC/DC charging harness.
- 11 Remove the integral AC/DC charging harness bracket bolt (1).
- 12 Remove the ground harness nut (2).
- 13 Remove the integral AC/DC charging harness assembly (3).

Power and Control System

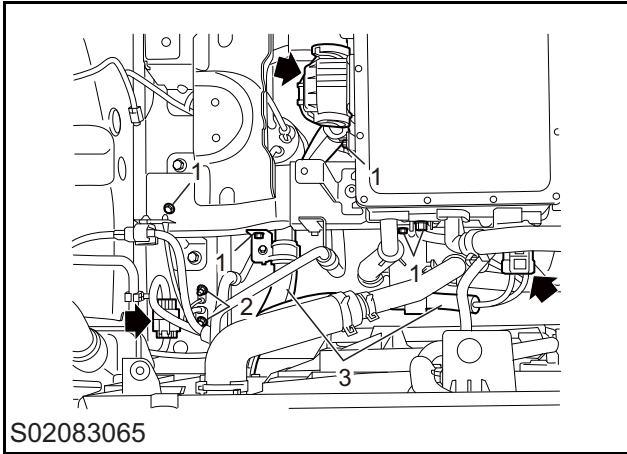

Installation

- 1 Install the integral AC/DC charging harness assembly.
- 2 Connect the high-voltage harness to the charging and distribution unit.
- 3 Connect the low-voltage harness to the integral AC/DC charging harness.
- 4 Install the ground harness nut.
- 5 Install the integral AC/DC charging harness bracket bolts, tighten them to 9 ± 1 Nm, and check the torque.
- 6 Install the integral AC/DC charging harness assembly bolts, tighten them to 9 ± 1 Nm, and check the torque.
- 7 Install the radiator grille assembly.
- 8 Install the sound absorbing cover. Refer to "Sound Absorbing Cover Replacement".
- 9 Install the service switch. Refer to "Service Switch Replacement".
- 10 Connect the negative battery cable.

Power Battery High-voltage Output Harness Assembly Replacement

Removal

- 1 Turn off the key power of the complete vehicle and wait for 3-5 minutes.
- 2 Disconnect the negative battery cable.
- 3 Remove the service switch. Refer to "Service Switch Replacement".
- 4 Remove the sound absorbing cover. Refer to "Sound Absorbing Cover Replacement".
- 5 Remove the power battery high-voltage output harness assembly bracket bolt (1).
- 6 Disconnect the power battery high-voltage output harness assembly from the charging and distribution unit.

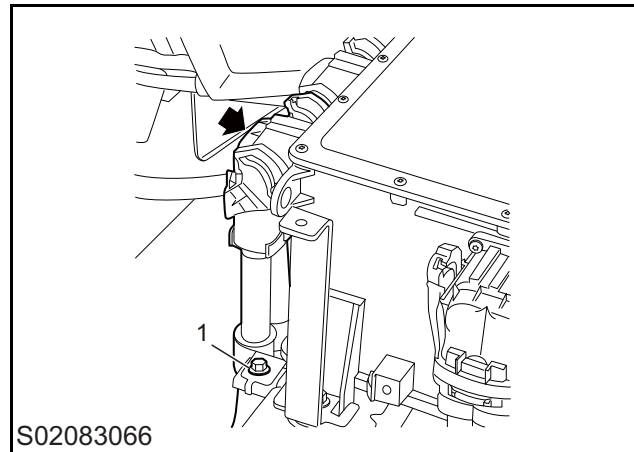

- 7 Raise the vehicle.
- 8 Remove the power battery high-voltage output harness assembly bracket bolt (1).
- 9 Remove the power battery high-voltage output harness assembly bracket nut (2).
- 10 Disconnect the power battery high-voltage output harness assembly from the power battery.
- 11 Remove the power battery high-voltage output harness assembly (3).

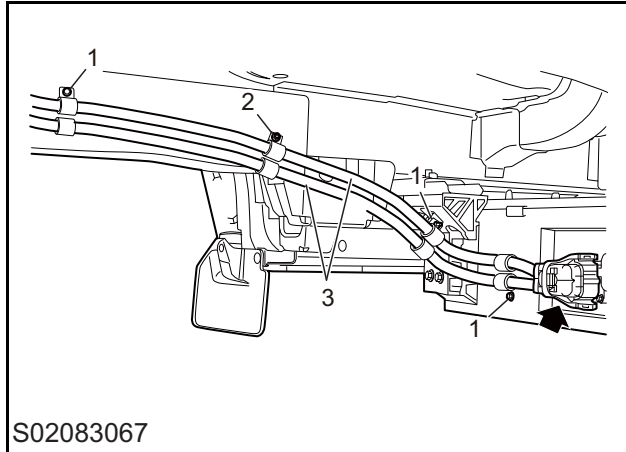

Installation

- 1 Install the power battery high-voltage output harness assembly.
- 2 Connect the high-voltage harness to the charging and distribution unit.
- 3 Connect the power battery high-voltage output harness assembly to the power battery.
- 4 Install the power battery high-voltage output harness assembly bracket nut, tighten it to 9 ± 1 Nm and check the torque.
- 5 Install the power battery high-voltage output harness assembly bracket bolt, tighten it to 9 ± 1 Nm and check the torque.
- 6 Connect the power battery high-voltage output harness assembly to the charging and distribution unit.
- 7 Install the sound absorbing cover. Refer to "Sound Absorbing Cover Replacement".
- 8 Install the service switch. Refer to "Service Switch Replacement".
- 9 Connect the negative battery cable.

Front Electric Heater High-voltage Harness Assembly Replacement

Removal

- 1 Turn off the key power of the complete vehicle and wait for 3-5 minutes.
- 2 Disconnect the negative battery cable.
- 3 Remove the service switch. Refer to "Service Switch Replacement".
- 4 Remove the front passenger footwell air duct.
- 5 Remove the middle lower guard plate.
- 6 Disconnect the front electric heater high-voltage harness assembly from the front electric heater.

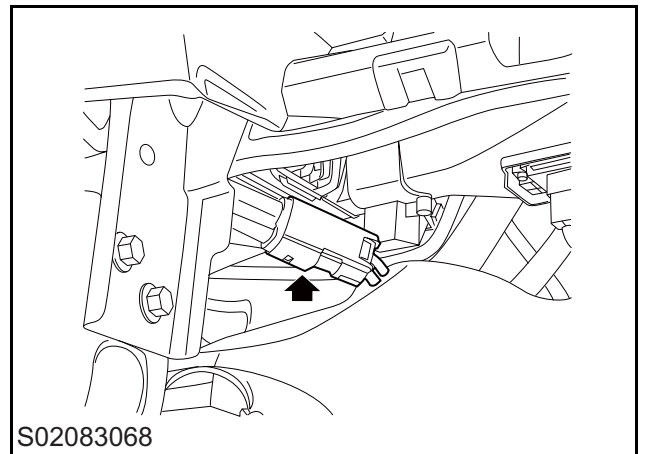

- 7 Remove the sound absorbing cover. Refer to "Sound Absorbing Cover Replacement".
- 8 Disconnect the front electric heater high-voltage harness assembly from the charging and distribution unit.
- 9 Disconnect the front electric heater high-voltage harness assembly from the vehicle body.
- 10 Remove the front electric heater high-voltage harness assembly (1).

Power and Control System

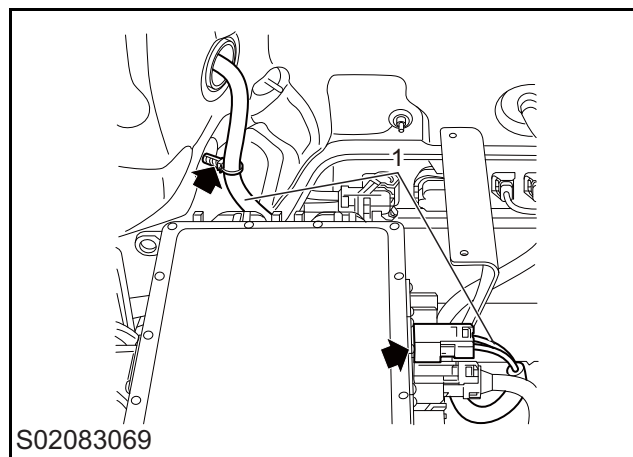

Installation

- 1 Install the front electric heater high-voltage harness assembly.
- 2 Connect the front electric heater high-voltage harness assembly to the vehicle body.
- 3 Connect the front electric heater high-voltage harness assembly to the charging and distribution unit.
- 4 Connect the front electric heater high-voltage harness assembly to the front electric heater.
- 5 Install the sound absorbing cover. Refer to "Sound Absorbing Cover Replacement".
- 6 Install the front passenger footwell air duct.
- 7 Install the middle lower guard plate.
- 8 Install the service switch. Refer to "Service Switch Replacement".
- 9 Connect the negative battery cable.

Rear Electric Heater High-voltage Harness Assembly Replacement

Removal

- 1 Turn off the key power of the complete vehicle and wait for 3-5 minutes.
- 2 Disconnect the negative battery cable.
- 3 Remove the service switch. Refer to "Service Switch Replacement".
- 4 Remove the sound absorbing cover. Refer to "Sound Absorbing Cover Replacement".
- 5 Disconnect the rear electric heater high-voltage harness assembly from the charging and distribution unit.
- 6 Disconnect the rear electric heater high-voltage harness assembly from the vehicle body.
- 7 Remove the rear electric heater high-voltage harness assembly bracket nut (1).

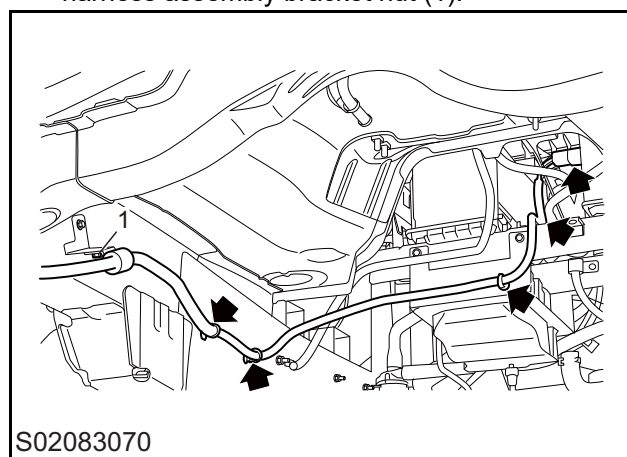

- 8 Disconnect the front electric heater high-voltage harness assembly from the vehicle body.
- 9 Disconnect the rear electric heater high-voltage harness assembly from the rear electric heater.
- 10 Remove the rear electric heater high-voltage harness assembly (1).

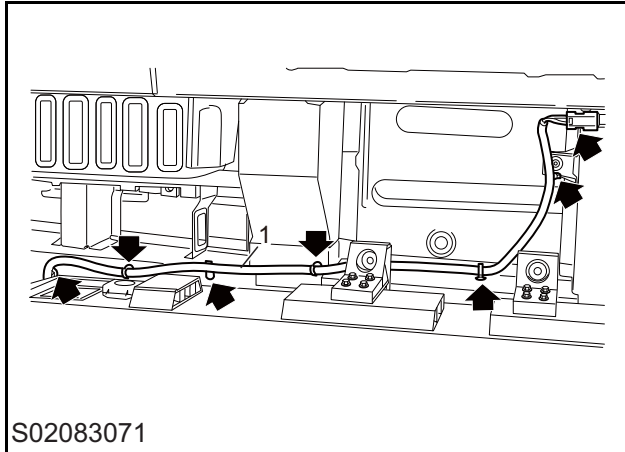

Installation

- 1 Install the rear electric heater high-voltage harness assembly.
- 2 Connect the rear electric heater high-voltage harness assembly to the vehicle body.
- 3 Connect the rear electric heater high-voltage harness assembly to the charging and distribution unit.
- 4 Connect the front electric heater high-voltage harness assembly to the rear electric heater.
- 5 Install the rear electric heater high-voltage harness assembly bracket nut and tighten it.
- 6 Install the sound absorbing cover. Refer to "Sound Absorbing Cover Replacement".
- 7 Install the service switch. Refer to "Service Switch Replacement".
- 8 Connect the negative battery cable.

Front Air Compressor Harness Assembly Replacement

Removal

- 1 Turn off the key power of the complete vehicle and wait for 3-5 minutes.
- 2 Disconnect the negative battery cable.
- 3 Remove the service switch. Refer to "Service Switch Replacement".
- 4 Do not disconnect the refrigerant pipe of the air compressor, but remove the left air compressor assembly.
- 5 Disconnect the front air compressor harness assembly from the front air compressor.
- 6 Remove the front air compressor harness assembly bracket bolt (1).

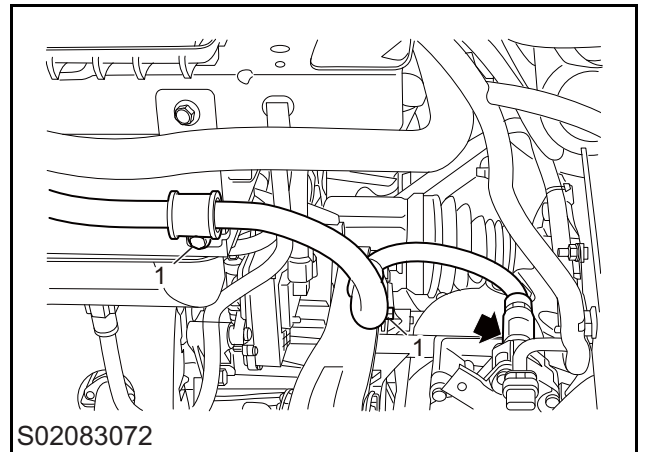

- 7 Remove the sound absorbing cover. Refer to "Sound Absorbing Cover Replacement".
- 8 Disconnect the front air compressor harness assembly from the charging and distribution unit.
- 9 Disconnect the front air compressor harness assembly from the vehicle body.
- 10 Remove the front air compressor harness assembly (1).

Power and Control System

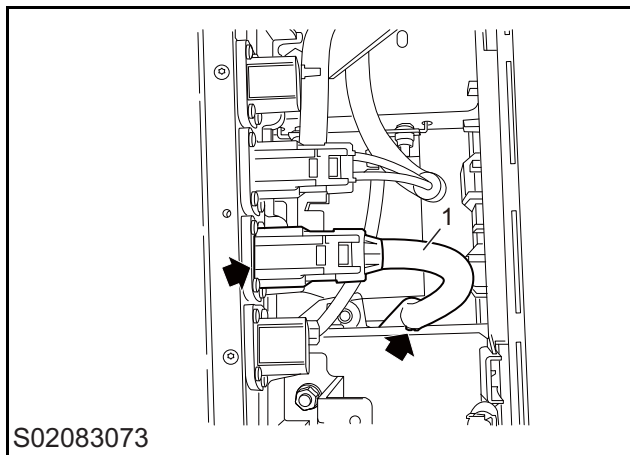

Installation

- 1 Install the front air compressor harness assembly.
- 2 Connect the front air compressor harness assembly to the vehicle body.
- 3 Connect the front air compressor harness assembly to the charging and distribution unit.
- 4 Connect the front air compressor harness assembly to the front air compressor.
- 5 Install the front air compressor harness assembly bracket bolt, tighten it to 9 ± 1 Nm and check the torque.
- 6 Install the sound absorbing cover. Refer to "Sound Absorbing Cover Replacement".
- 7 Install the air compressor assembly.
- 8 Install the service switch. Refer to "Service Switch Replacement".
- 9 Connect the negative battery cable.

Rear Air Compressor Harness Assembly Replacement

Removal

- 1 Turn off the key power of the complete vehicle and wait for 3-5 minutes.
- 2 Disconnect the negative battery cable.
- 3 Raise the vehicle.
- 4 Remove the service switch. Refer to "Service Switch Replacement".
- 5 Disconnect the rear air compressor harness assembly from the front air compressor.
- 6 Remove the rear air compressor harness assembly bracket nut (1).

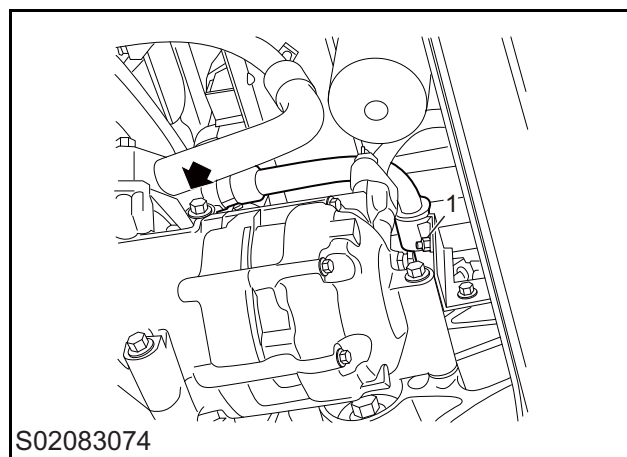

- 7 Remove the sound absorbing cover. Refer to "Sound Absorbing Cover Replacement".
- 8 Disconnect the rear air compressor harness assembly from the charging and distribution unit.
- 9 Disconnect the bolt (1) connecting the rear air compressor harness assembly to the vehicle body.
- 10 Remove the rear air compressor harness assembly (2).

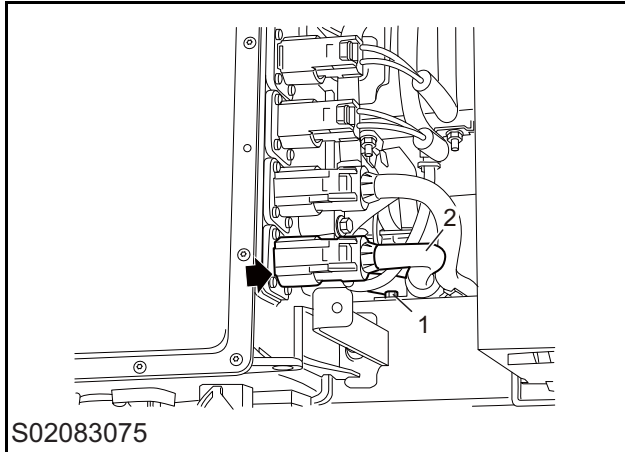

Installation

- 1 Install the rear air compressor harness assembly.
- 2 Install the bolt connecting the rear air compressor harness assembly to the vehicle body, tighten it to 9 ± 1 Nm and check the torque.
- 3 Connect the rear air compressor harness assembly to the charging and distribution unit.
- 4 Connect the rear air compressor harness assembly to the rear air compressor.
- 5 Install the rear air compressor harness assembly bracket nut, tighten it to 9 ± 1 Nm and check the torque.
- 6 Install the sound absorbing cover. Refer to "Sound Absorbing Cover Replacement".
- 7 Install the service switch. Refer to "Service Switch Replacement".
- 8 Connect the negative battery cable.

Low-speed Alarm Module Replacement

Removal

- 1 Disconnect the negative battery cable.
- 2 Remove the front grille assembly.
- 3 Disconnect the electrical connector of the low-speed alarm module.
- 4 Remove 2 low-speed alarm module bolts (1).
- 5 Remove the low-speed alarm module (2).

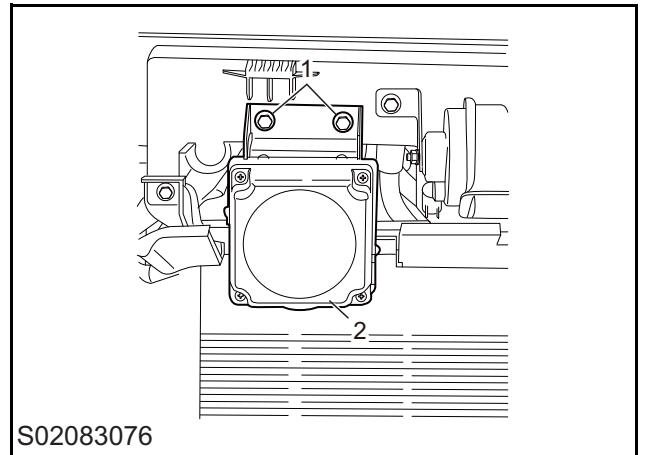

Installation

- 1 Install the low-speed alarm module.
- 2 Install 2 low-speed alarm module bolts, tighten them to 9 ± 1 Nm and check the torque.
- 3 Connect the electrical connector of the low-speed alarm module.
- 4 Install the front grille assembly.
- 5 Connect the negative battery cable.

Power and Control System

Electric Vehicle Communication Controller Replacement

Removal

- 1 Disconnect the negative battery cable.
- 2 Remove the service switch. Refer to "Service Switch Replacement".
- 3 Remove the complete vehicle controller. Refer to "Complete Vehicle Controller Replacement".
- 4 Disconnect the electrical connector of the electric vehicle communication controller.
- 5 Remove the bracket bolt (1).
- 6 Remove the bracket (2) and the electric vehicle communication controller together.

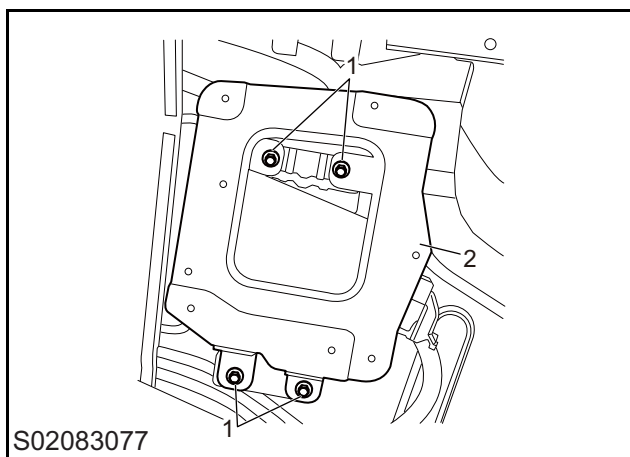

- 7 Remove the electric vehicle communication controller bolt (1).
- 8 Remove the electric vehicle communication controller (2).

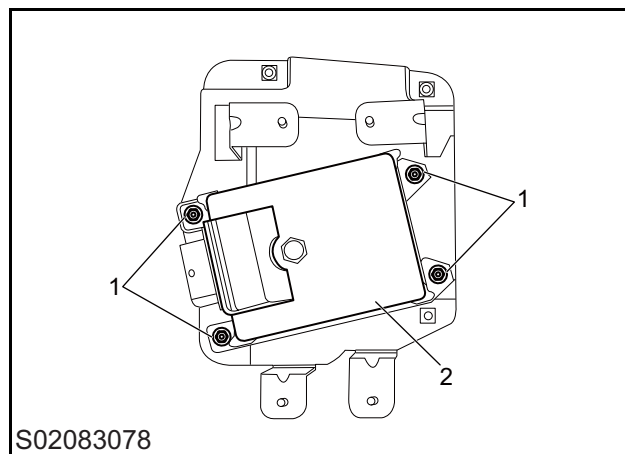

Installation

- 1 Install the electric vehicle communication controller and its bracket.
- 2 Install the electric vehicle communication controller bolts, tighten them to 9 ± 1 Nm, and check the torque.
- 3 Install the bracket and the electric vehicle communication controller assembly to the vehicle body.
- 4 Install the bracket bolts, tighten them to 9 ± 1 Nm, and check the torque.
- 5 Connect the electrical connector of the electric vehicle communication controller.
- 6 Install the complete vehicle controller. Refer to "Complete Vehicle Controller Replacement".
- 7 Install the service switch. Refer to "Service Switch Replacement".
- 8 Connect the negative battery cable.

Complete Vehicle Controller Replacement

Removal

- 1 Disconnect the negative battery cable.
- 2 Remove the service switch. Refer to "Service Switch Replacement".
- 3 Disconnect the electrical connector of the complete vehicle controller.
- 4 Remove the complete vehicle controller bolt (1).
- 5 Remove the complete vehicle controller (2).

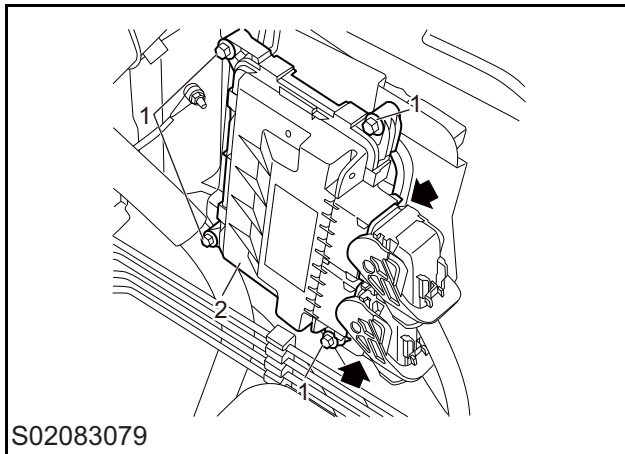

Installation

- 1 Install the complete vehicle controller.
- 2 Install the complete vehicle controller bolts, tighten them to 9 ± 1 Nm and check the torque.
- 3 Connect the electrical connector of the complete vehicle controller.
- 4 Install the service switch. Refer to "Service Switch Replacement".
- 5 Connect the negative battery cable.
- 6 Perform the self-learning operation to the complete vehicle controller again.

Power Cooling System

Specification

Fastener Specifications

Name	Torque (Nm)
Bolt - Electric Water Pump	5 ± 1 Nm
Bolt - Cooling Module Supporting Plate	22 ± 2 Nm
Bolt - Motor to Radiator Hose Bracket	9 ± 1 Nm

Parameter Specification

Coolant Capacity

Items	Grade	Capacity
Coolant (Electric Drive System), L	D-35(-35 °C)	6

Power Cooling System

Layout

Cooling System Layout

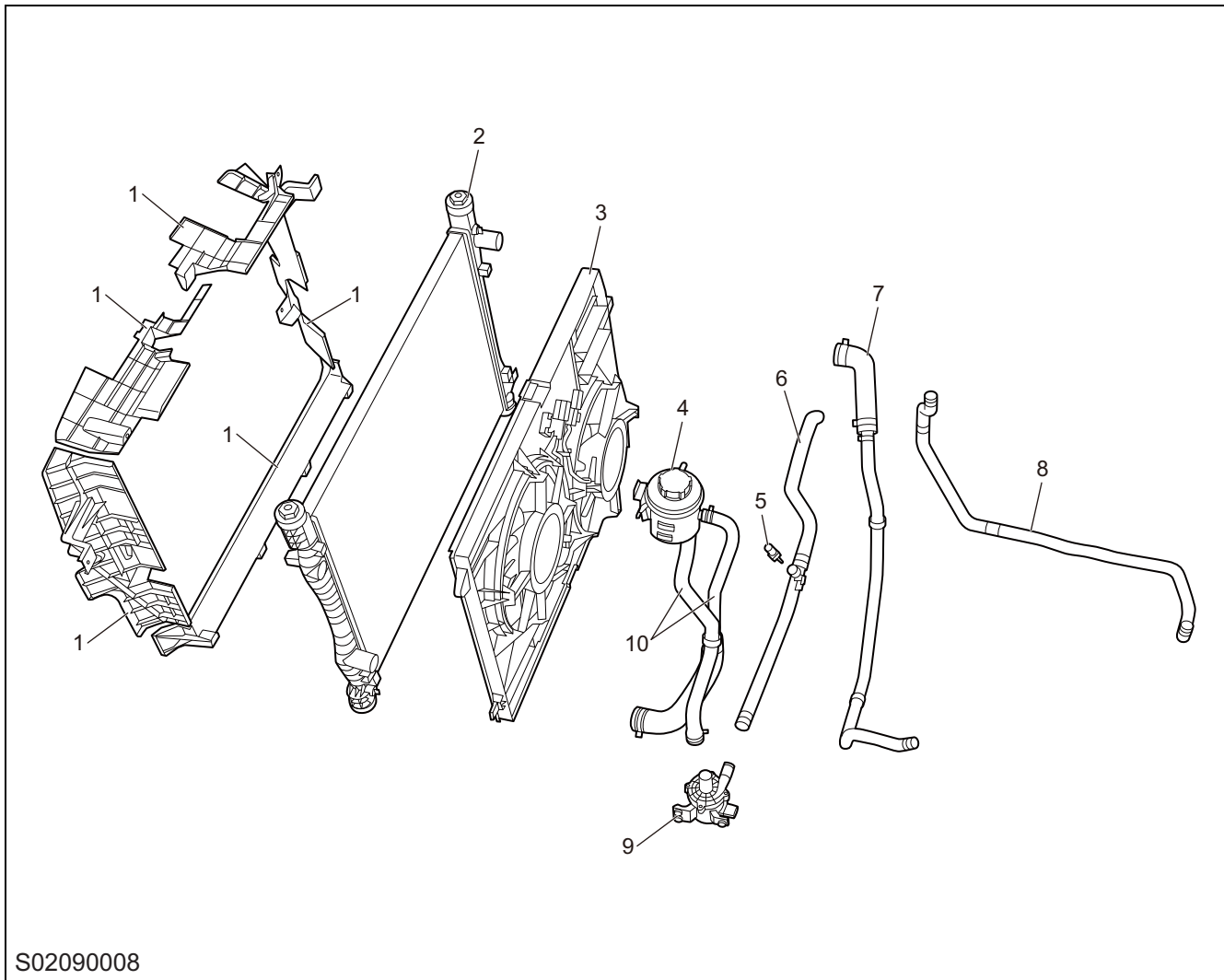

- 1 Air intake deflector
- 2 Radiator
- 3 Fan with shroud assembly
- 4 Expansion tank
- 5 Water temperature sensor
- 6 Electric water pump to motor controller hose
- 7 Radiator inlet pipe
- 8 Motor controller to motor hose
- 9 Electric water pump
- 10 Expansion tank to water pump hose

Service Guide

Motor Coolant Drain and Refill

Drain

- 1 Remove the expansion tank cap.

Warning: Spilled steam or coolant can cause injuries such as burns, so do not open the expansion tank cap when the cooling system is still hot.

- 2 Raise the vehicle.
- 3 Secure a suitable container to collect the coolant.
- 4 Disconnect the clamp at the electric drive end of the radiator inlet hose.
- 5 Drain the coolant.

Refill

- 1 Install the clamp at the electric drive end of the radiator inlet hose.
- 2 Refill the coolant, until the coolant reaches the MAX line of the expansion tank and remains stationary.
- 3 Connect the scan tool, conduct actuator test - VCU- motor cooling water pump enabling operation, to make the electric water pump work, and the coolant in the expansion tank will be immediately drained; then immediately refill the coolant between MIN and MAX, and repeat the process 3-5 times until the liquid level of the expansion tank is stable.

Caution: Always refill the coolant within 13 seconds after the antifreeze of the expansion tank is drained, otherwise it may trigger the water pump dry-run protection mechanism.

- 4 Continue to run the water pump for 15 minutes after the liquid level is stable, and the liquid level of the expansion tank has no decline.
- 5 Check the coolant level of the expansion tank, and check the cooling system for leakage.
- 6 Install the expansion tank cap.
- 7 Lower the vehicle.

Electric Water Pump Replacement

Removal

- 1 Disconnect the negative battery cable.
- 2 Remove the service switch. Refer to "Service Switch Replacement".
- 3 Drain the coolant of electric drive system.
- 4 Lift the vehicle to the appropriate height.
- 5 Disconnect the water pipe of the electric water pump.
- 6 Remove the retaining bolt (1) of the electric water pump.
- 7 Remove the electric water pump (2).

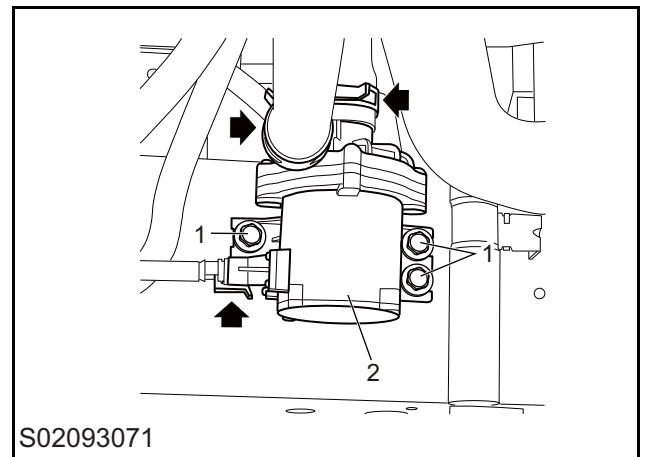

Installation

- 1 Install the electric water pump.
- 2 Install the electric water pump retaining bolts, tighten them to 5 ± 1 Nm, and check the torque.
- 3 Connect the water pipe of the electric water pump.
- 4 Fill the coolant of electric drive system.
- 5 Install the service switch. Refer to "Service Switch Replacement".
- 6 Connect the negative battery cable.

Power Cooling System

Water Temperature Sensor Replacement

Removal

- 1 Disconnect the negative battery cable.
- 2 Remove the service switch. Refer to "Service Switch Replacement".
- 3 Drain the coolant of electric drive system.
- 4 Disconnect the electrical connector of the water temperature sensor.
- 5 Remove the water temperature sensor (1).

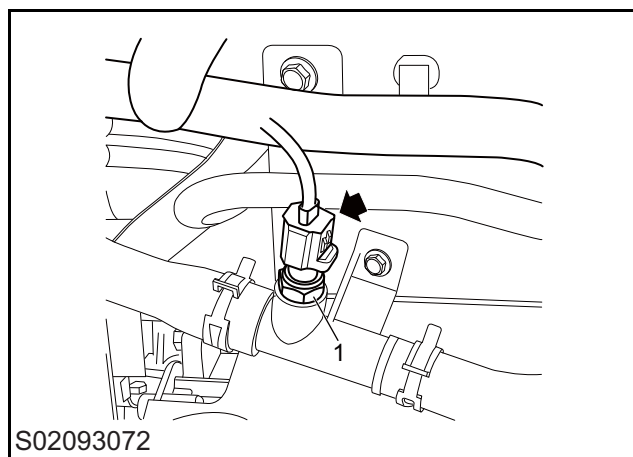

Installation

- 1 Install the water temperature sensor.
- 2 Connect the electrical connector of the water temperature sensor.
- 3 Fill the coolant of electric drive system.
- 4 Install the service switch. Refer to "Service Switch Replacement".
- 5 Connect the negative battery cable.

Expansion Tank Replacement

Removal

- 1 Disconnect the negative battery cable.
- 2 Drain the coolant of electric drive system.
- 3 Disconnect the hose from the expansion tank.
- 4 Remove the expansion tank (1) upwards.
- 5 If necessary, remove the bracket bolt (2) and the bracket (3).

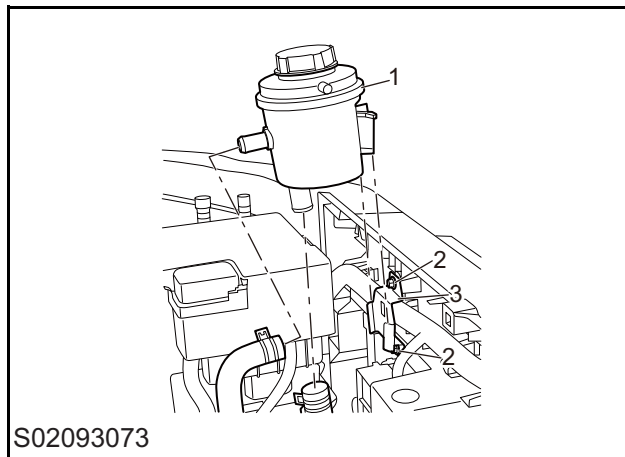

Installation

- 1 If necessary, install the bracket and the bracket bolt and tighten them.
- 2 Install the expansion tank on the bracket.
- 3 Install the hose connected to the expansion tank.
- 4 Fill the coolant of electric drive system.
- 5 Install the service switch. Refer to "Service Switch Replacement".
- 6 Connect the negative battery cable.

Electric Water Pump to Motor Controller Hose Replacement

Removal

- 1 Disconnect the negative battery cable.
- 2 Remove the service switch. Refer to "Service Switch Replacement".
- 3 Drain the coolant of electric drive system.
- 4 Disconnect the electric water pump to motor controller hose from the charging and distribution unit.
- 5 Disconnect the electric water pump to motor controller hose from the electric water pump.
- 6 Disconnect the water temperature sensor harness connector from the electric water pump to motor controller hose.
- 7 Remove the electric water pump to motor controller hose bracket bolt (1).
- 8 Remove the electric water pump to motor controller hose (2).

- 7 Install the service switch. Refer to "Service Switch Replacement".
- 8 Connect the negative battery cable.

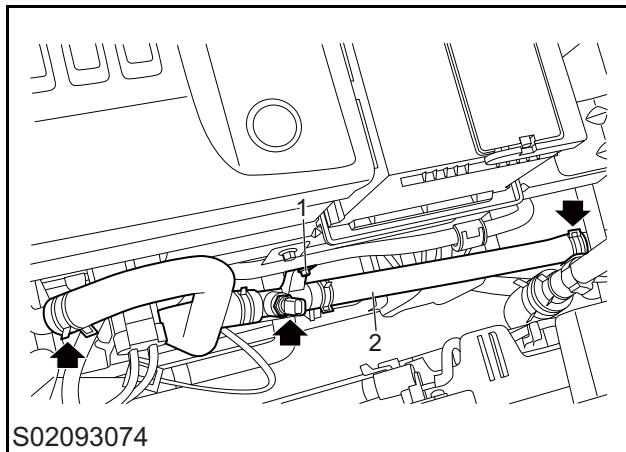

Installation

- 1 Install the electric water pump to motor controller hose.
- 2 Install the electric water pump to motor controller hose bracket bolt and tighten it.
- 3 Connect the electric water pump to motor controller hose to the electric water pump.
- 4 Install the electric water pump to motor controller hose to the charging and distribution unit.
- 5 Install the water temperature sensor harness connector.
- 6 Fill the coolant of electric drive system.

Power Cooling System

Radiator Inlet Pipe Replacement

Removal

- 1 Disconnect the negative battery cable.
- 2 Remove the service switch. Refer to "Service Switch Replacement".
- 3 Drain the coolant of electric drive system.
- 4 Disconnect the radiator inlet pipe from the radiator.
- 3 Connect the radiator inlet pipe to the vehicle body.
- 4 Connect the radiator inlet pipe to the radiator.
- 5 Fill the coolant of electric drive system.
- 6 Install the service switch. Refer to "Service Switch Replacement".
- 7 Connect the negative battery cable.

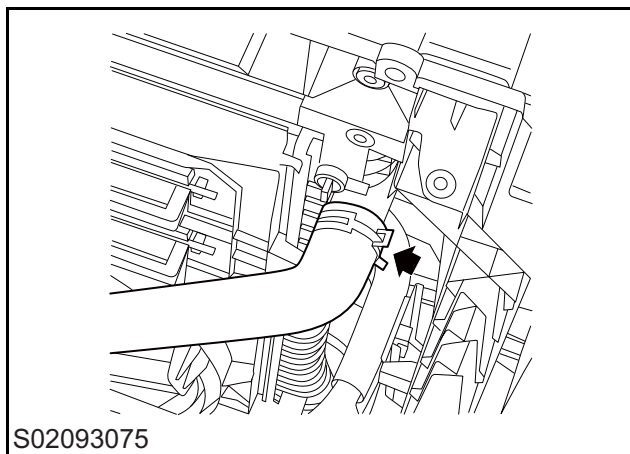

- 5 Disconnect the radiator inlet pipe from the electric drive assembly.
- 6 Disconnect the radiator inlet pipe from the vehicle body.
- 7 Disconnect the radiator inlet pipe from the harness clip.
- 8 Remove the radiator inlet pipe (1).

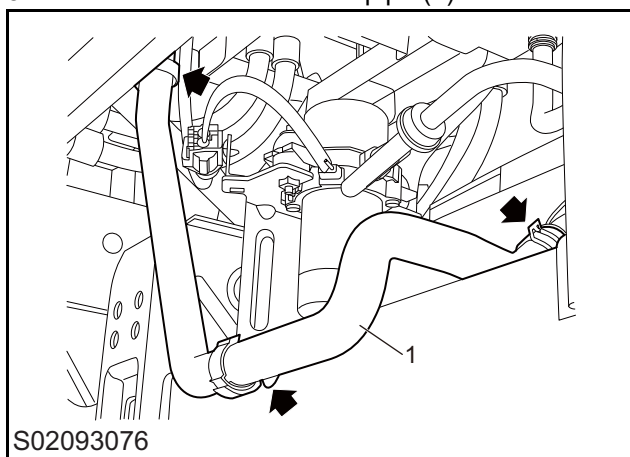

Installation

- 1 Install the radiator inlet pipe.
- 2 Connect the radiator inlet pipe to the electric drive assembly.

Expansion Tank to Water Pump Hose Replacement

Removal

- 1 Disconnect the negative battery cable.
- 2 Remove the service switch. Refer to "Service Switch Replacement".
- 3 Drain the coolant of electric drive system.
- 4 Disconnect the expansion tank to water pump hose from the expansion tank.
- 5 Disconnect the expansion tank to water pump hose from the radiator.
- 6 Disconnect the expansion tank to water pump hose from the electric water pump.
- 7 Remove the expansion tank to water pump hose (1).

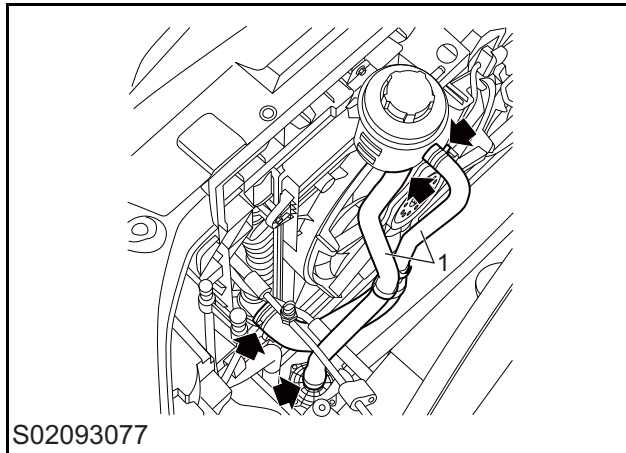

Installation

- 1 Install the electric water pump to charger water pipe.
- 2 Install the expansion tank to water pump hose to the electric water pump.
- 3 Install the expansion tank to water pump hose to the radiator.
- 4 Install the expansion tank to water pump hose to the expansion tank.
- 5 Fill the coolant of electric drive system.
- 6 Install the service switch. Refer to "Service Switch Replacement".
- 7 Connect the negative battery cable.

Motor Controller to Motor Hose Replacement Removal

- 1 Disconnect the negative battery cable.
- 2 Remove the service switch. Refer to "Service Switch Replacement".
- 3 Drain the coolant of electric drive system.
- 4 Disconnect the motor controller to motor hose from the charging and distribution unit.
- 5 Disconnect the motor controller to motor hose from the vehicle body.

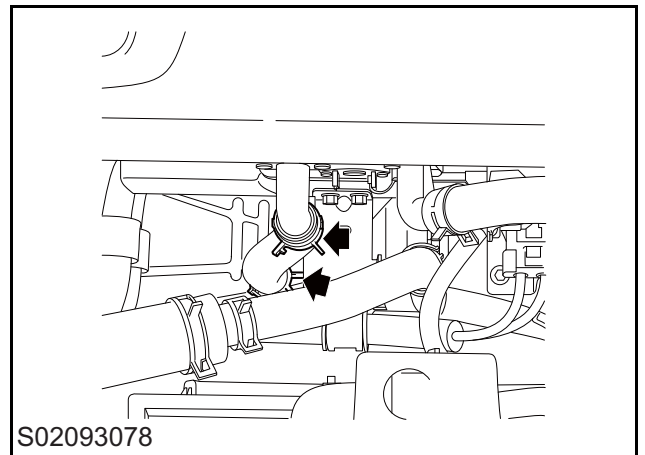

- 6 If the right A/C compressor is equipped, do not remove the refrigerant pipe, but remove the right A/C compressor.
- 7 Disconnect the motor controller to motor hose from the electric drive assembly.
- 8 Remove the motor controller to motor hose bracket bolt (1).
- 9 Remove the motor controller to motor hose (2).

Power Cooling System

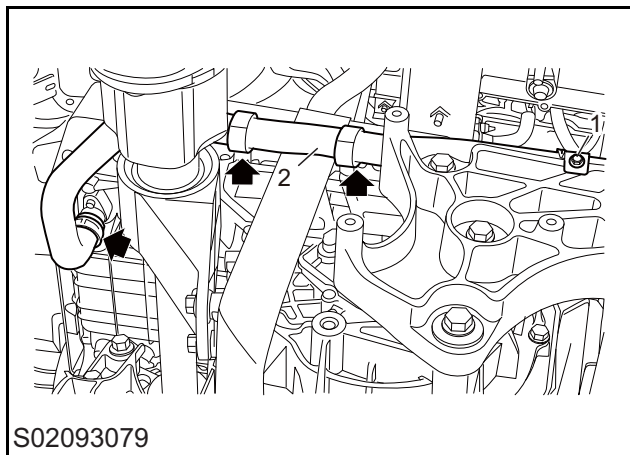

Installation

- 1 Install the motor controller to motor hose.
- 2 Install the motor controller to motor hose to the electric drive assembly.
- 3 Install the motor controller to motor hose bracket bolt and tighten it.
- 4 If the right A/C compressor is equipped, install the right A/C compressor.
- 5 Fix the motor controller to motor hose to the vehicle body.
- 6 Install the motor controller to motor hose to the charging and distribution unit.
- 7 Fill the coolant of electric drive system.
- 8 Install the service switch. Refer to "Service Switch Replacement".
- 9 Connect the negative battery cable.

Air Intake Deflector Replacement (Upper)

Removal

- 1 Remove the radiator grille.
- 2 Remove the air intake deflector bolt (1) and clip (2).
- 3 Remove the upper air intake deflector (3).

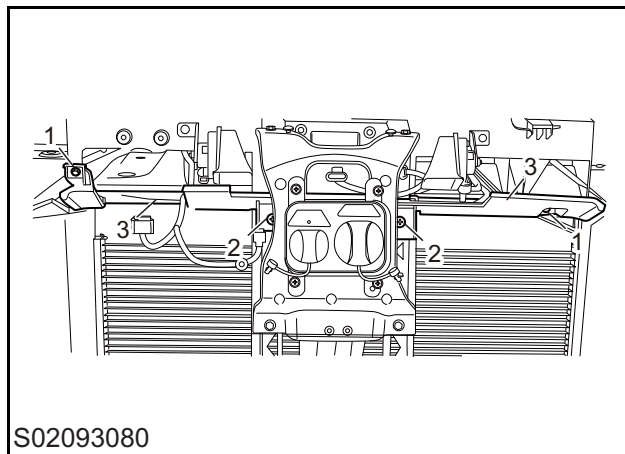

Installation

- 1 Install the upper air intake deflector.
- 2 Install the air intake deflector clip and bolt and tighten them.
- 3 Install the radiator grille.

Air Intake Deflector Replacement (Lower)

Removal

- 1 Remove the front bottom deflector.
- 2 Remove the air intake deflector clip (1) and bolt (2).
- 3 Remove the lower air intake deflector (3).

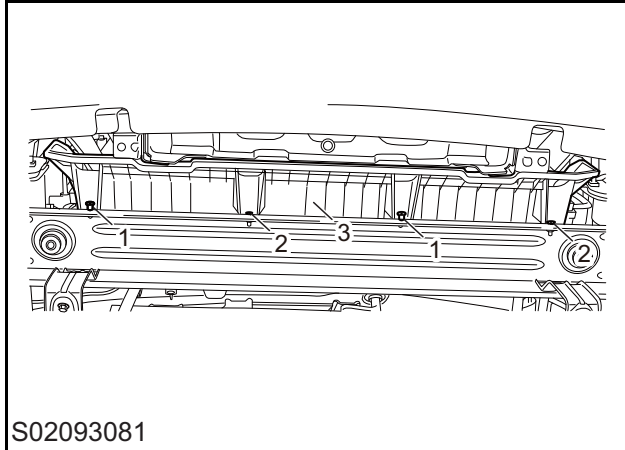

Installation

- 1 Install the lower air intake deflector.
- 2 Install the air intake deflector clip and bolt and tighten them.
- 3 Install the front bottom deflector.

Air Intake Deflector Replacement (Both Sides)

Removal

- 1 Remove the radiator grille.
- 2 Remove the air intake deflector bolt (1).
- 3 Remove the air intake deflectors (2) on both sides.

Caution: For the left side, it is required to remove the charging harness bracket bolt, and remove the charging harness.

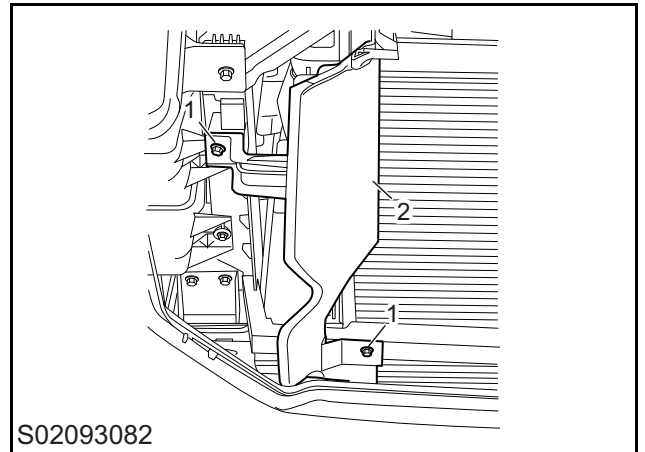

Installation

- 1 Install the air intake deflectors on both sides.
- 2 Install the air intake deflector bolt and tighten it.
- 3 Install the radiator grille.

Power Cooling System

Cooling Module Assembly Replacement

Removal

- 1 Disconnect the negative battery cable.
- 2 Remove the service switch. Refer to "Service Switch Replacement".
- 3 Drain the coolant.
- 4 Recover the refrigerant.
- 5 Remove the front bumper. Refer to "Front Bumper Assembly Replacement".
- 6 Remove the front grille. Refer to "Front Grille Replacement".
- 7 Remove the air intake deflector. Refer to "Air Intake Deflector Replacement".
- 8 Disconnect the cooling water pipe.
- 9 Disconnect the refrigerant pipe.
- 10 Remove the cooling module supporting plate bolt (1).
- 11 Remove the cooling module supporting plate (2).
- 12 Remove the cooling module assembly (3).

- 4 Install the cooling module supporting plate.
- 5 Install the cooling module supporting plate bolts, tighten them to 22 ± 2 Nm and check the torque.
- 6 Install the front grille. Refer to "Front Grille Replacement".
- 7 Install the front bumper. Refer to "Front Bumper Assembly Replacement".
- 8 Refill the refrigerant.
- 9 Refill the coolant.
- 10 Install the service switch. Refer to "Service Switch Replacement".
- 11 Connect the negative battery cable.

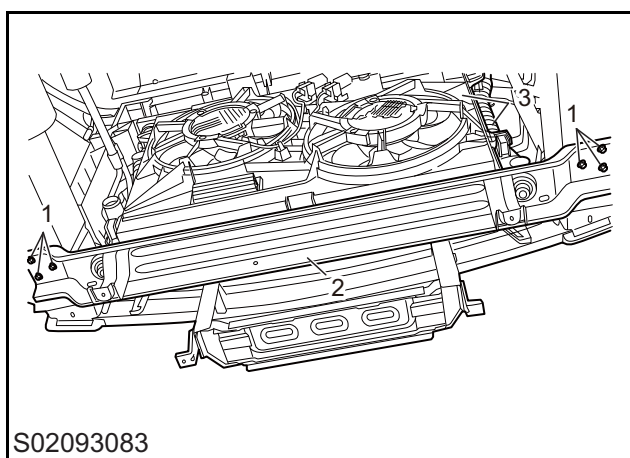

- 13 If necessary, separate the condenser assembly, the fan with shroud assembly and the radiator assembly.

Installation

- 1 If necessary, assemble the condenser assembly, the fan with shroud assembly and the radiator assembly.
- 2 Install the fan with shroud assembly bolt and the condenser assembly bolt, tighten them to 9 ± 1 Nm, and check the torque.
- 3 Install the cooling module assembly.

Shift Manipulation Control System

Specification

Fastener Specifications

Name	Torque (Nm)
Nut - Transmission Control Lever	20 ± 2 Nm

Shift Manipulation Control System

Layout

Shift Manipulation Control Layout

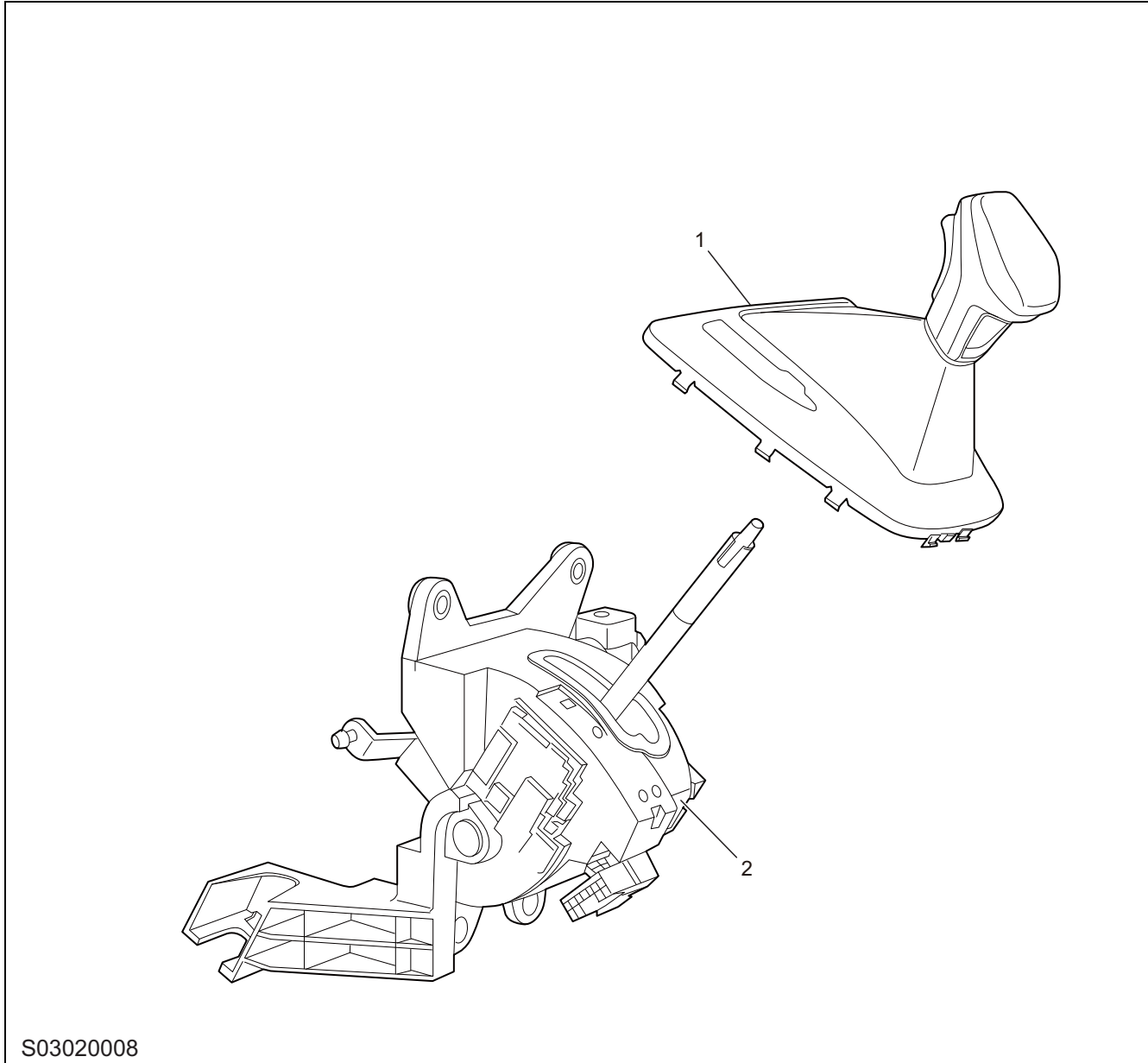

S03020008

1 Transmission control handle assembly

2 Transmission control lever assembly

Service Guide

Shifting Handle Assembly Replacement

Removal

- 1 Pry the shifting lever protecting sleeve.
- 2 Carefully pull up the shifting lever handle, and remove the shifting handle assembly (1) from the shifting lever.

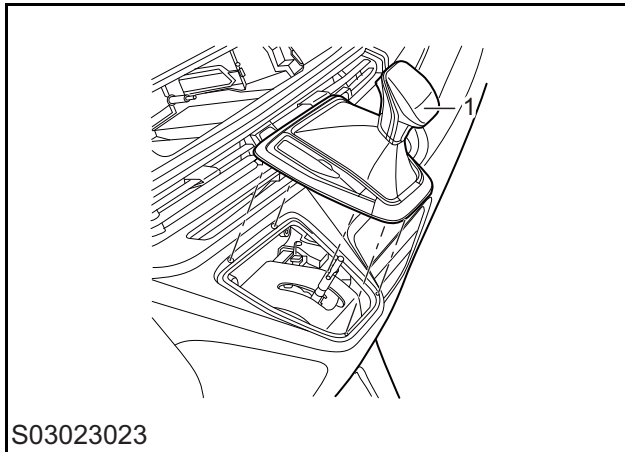

Installation

- 1 Locate the protecting sleeve on the shifting lever of gear shifter.
- 2 Press the handle into shifting lever and in place.
- 3 Clamp the shifting handle assembly onto the center console lower panel assembly.

Transmission Control Lever Assembly Replacement

Removal

- 1 Disconnect the negative battery cable.
- 2 Remove the instrument panel lower body assembly. Refer to "Instrument Panel Lower Body Assembly Replacement".
- 3 Disconnect the electrical connector of the control lever.
- 4 Remove 4 transmission control lever nuts (1).
- 5 Remove the transmission control lever assembly (2).

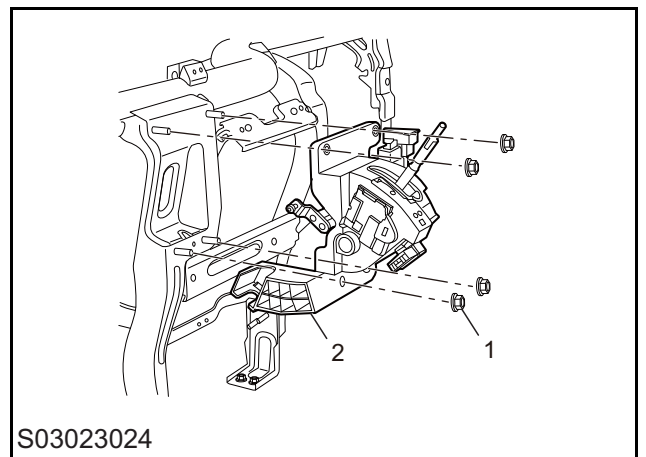

Installation

- 1 Locate the transmission control lever to the instrument panel beam.
- 2 Install 4 transmission control lever nuts, tighten them to 20 ± 2 Nm, and check the torque.
- 3 Connect the electrical connector of the control lever.
- 4 Install the instrument panel lower body assembly. Refer to "Instrument Panel Lower Body Assembly Replacement".
- 5 Connect the negative battery cable.

Brake System

Specification

Fastener Specifications

Name	Torque (Nm)
Nut - Vacuum Booster	18.5 ± 1.5 Nm
Bolt - Electronic Vacuum Pump	9 ± 1 Nm
Bolt - Electronic Vacuum Pump Bracket	23 ± 2 Nm
Bolt - Vacuum Cylinder	23 ± 2 Nm
Bolt - PDU Retaining Bracket Assembly	50 ± 5 Nm

Brake System

Layout

Brake Booster Pipeline Layout

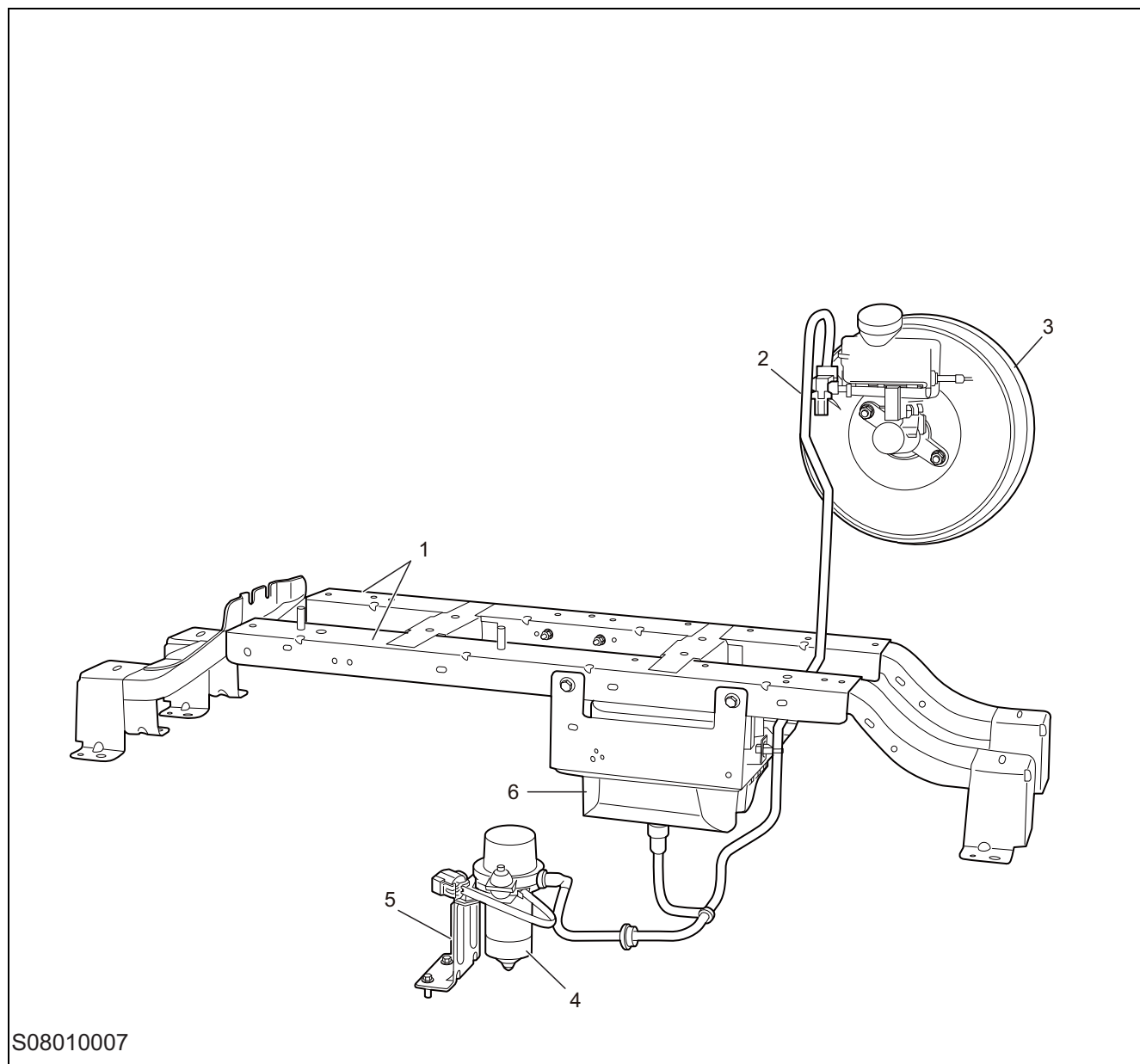

- 1 PDU retaining bracket assembly
- 2 Vacuum tube assembly
- 3 Vacuum booster assembly

- 4 Electronic vacuum pump
- 5 Electronic vacuum pump bracket
- 6 Vacuum cylinder assembly

Service Guide

Vacuum Booster Assembly Replacement

Removal

- 1 Disconnect the negative battery cable.
- 2 Disconnect the vacuum tube vacuum sensor connector, and then disconnect the vacuum tube (1) from the vacuum booster.

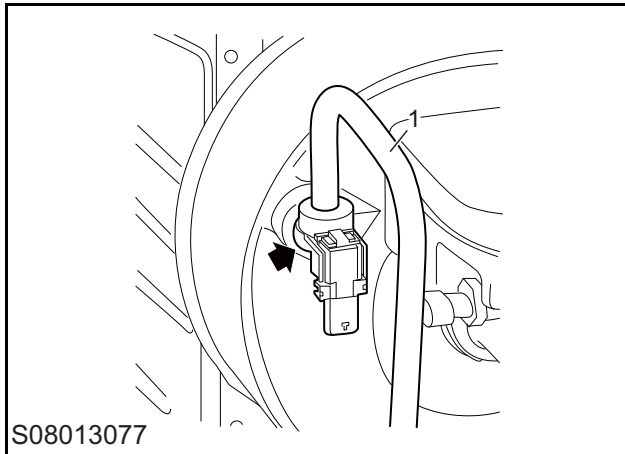

Caution: Be careful not to apply too much force during disassembly to avoid damage to the joint of vacuum tube. Be careful not to damage the connector when installing and removing the vacuum tube with the vacuum sensor and pay attention to waterproof protection.

- 3 Remove the elastic clips and lock pins fixing the vacuum booster push rod to the brake pedal.
- 4 Remove 4 nuts (2) of the vacuum booster.
- 5 Remove the vacuum booster assembly (1) and pads from the vehicle.

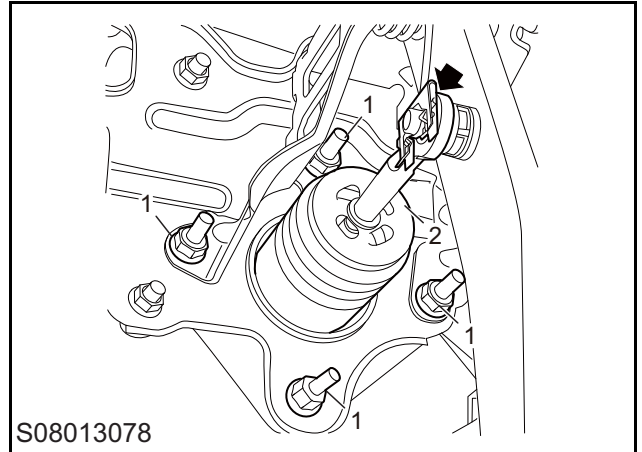

Installation

- 1 Install the vacuum booster assembly and pads.
- 2 Install 4 nuts of the vacuum booster, tighten them to 18.5 ± 1.5 Nm and check the torque.
- 3 Install the elastic clips and lock pins connecting the vacuum booster to the brake pedal.
- 4 Connect the vacuum tube to the vacuum booster.

Caution: Be careful not to let dust and impurities enter the vacuum tube. If it is hard to install the vacuum tube, specified grease for vacuum tube installation is required to lubricate the vacuum tube. It cannot be replaced by other liquids or lubricants.

- 5 Connect the vacuum booster vacuum sensor connector.
- 6 Bleed the brake system.
- 7 Connect the negative battery cable.

Brake System

Electronic Vacuum Pump Replacement

Removal

- 1 Disconnect the negative battery cable.
- 2 Remove the front bottom deflector.
- 3 Disconnect the harness from the vacuum pump connector.
- 4 Disconnect the vacuum pump connector from the bracket.
- 5 Disconnect the vacuum tube from the vacuum pump.
- 6 Remove the bolt (1) of the electronic vacuum pump.
- 7 Remove the electronic vacuum pump (2).

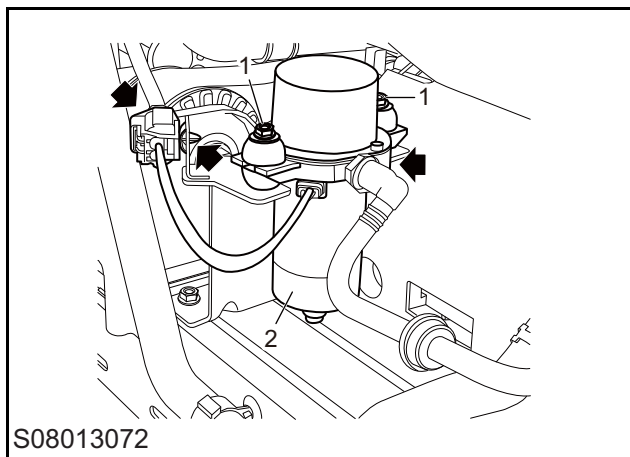

Installation

- 1 Install the electronic vacuum pump.
- 2 Install the electronic vacuum pump bolts, tighten them to 9 ± 1 Nm, and check the torque.
- 3 Connect the quick connector of the vacuum tube to the vacuum pump.
- 4 Connect the connector of the vacuum pump.
- 5 Install the front bumper assembly. Refer to "Front Bumper Assembly Replacement".
- 6 Connect the negative battery cable.

Electronic Vacuum Pump Bracket Replacement

Removal

- 1 Disconnect the negative battery cable.
- 2 Remove the electronic vacuum pump. Refer to "Electronic Vacuum Pump Replacement".
- 3 Remove the electronic vacuum pump bracket bolt (1).
- 4 Remove the electronic vacuum pump bracket (2).

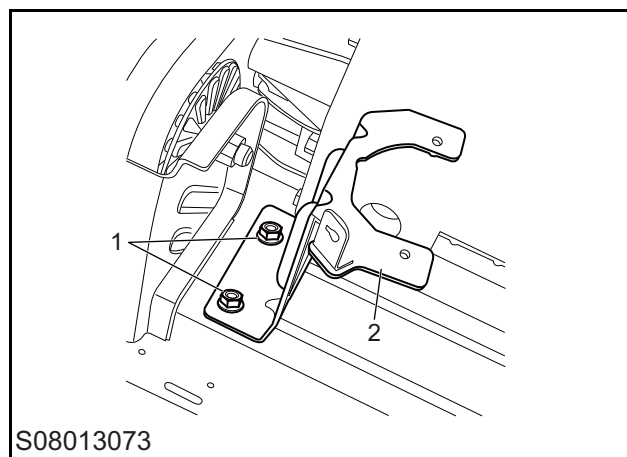

Installation

- 1 Install the electronic vacuum pump bracket.
- 2 Install the electronic vacuum pump bracket bolts, tighten them to 23 ± 2 Nm, and check the torque.
- 3 Install the electronic vacuum pump. Refer to "Electronic Vacuum Pump Replacement".
- 4 Connect the negative battery cable.

Vacuum Cylinder Replacement

Removal

- 1 Raise the vehicle.
- 2 Remove the suspension beam assembly. Refer to "Suspension Beam Assembly Replacement".
- 3 Disconnect the vacuum cylinder from the vacuum tube.
- 4 Remove the bolt (1) - vacuum cylinder to vehicle body.
- 5 Remove the vacuum cylinder (2).

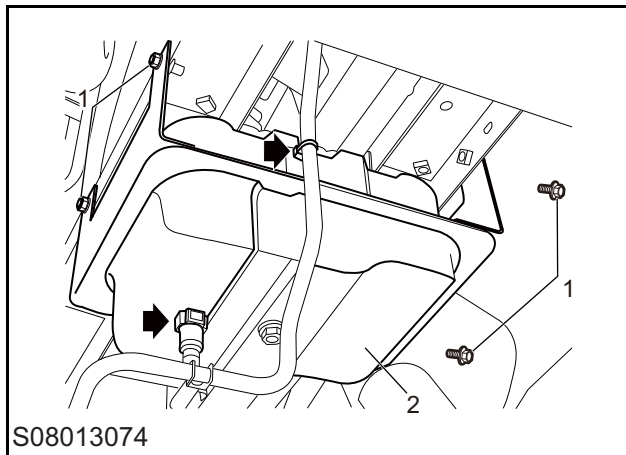

Installation

- 1 Install the vacuum cylinder.
- 2 Install the vacuum cylinder bolts, tighten them to 23 ± 2 Nm, and check the torque.
- 3 Connect the vacuum tube to the vacuum cylinder.
- 4 Install the suspension beam assembly. Refer to "Suspension Beam Assembly Replacement".
- 5 Lower the vehicle.

Vacuum Tube Assembly Replacement

Removal

- 1 Disconnect the negative battery cable.
- 2 Disconnect the vacuum tube assembly from the vacuum pump.
- 3 Disconnect the vacuum cylinder from the vacuum tube.

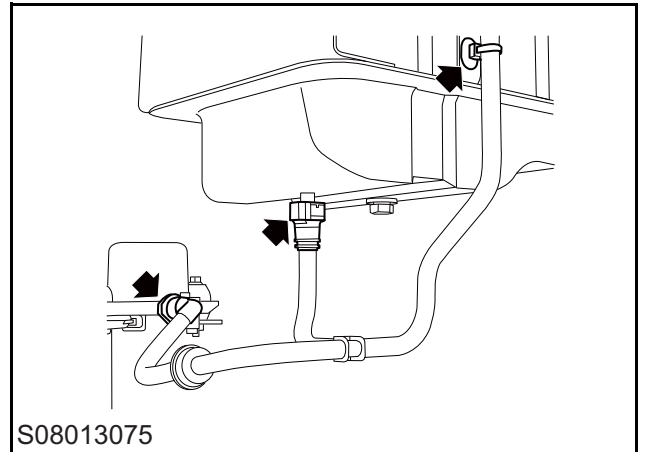

- 4 Disconnect the vacuum tube vacuum sensor connector.
- 5 Remove the vacuum tube (1) from the vacuum booster.

Caution: Be careful not to apply too much force during disassembly to avoid damage to the joint of vacuum tube. Be careful not to damage the connector when installing and removing the vacuum tube with the vacuum sensor and pay attention to waterproof protection.

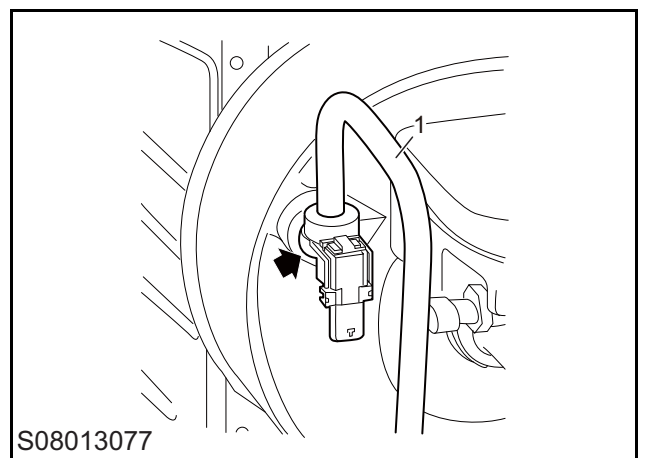

Installation

- 1 Install the vacuum tube.

Brake System

- 2 Connect the vacuum tube vacuum sensor connector.
- 3 Connect the vacuum cylinder to the vacuum tube.
- 4 Connect the vacuum tube assembly to the vacuum pump.
- 5 Disconnect the negative battery cable.

PDU Retaining Bracket Assembly Replacement

Removal

- 1 Disconnect the negative battery cable.
- 2 Remove the manual service disconnect. Refer to "Manual Service Disconnect Replacement".
- 3 Drain the coolant. Refer to "Coolant Drain".
- 4 Remove the charging and distribution unit. Refer to "Charging and Distribution Unit Replacement".
- 5 Remove the battery bracket. Refer to "Battery Bracket Replacement".
- 6 Remove the fuse box and its bracket.
- 7 Remove the vacuum cylinder retaining bolt. Refer to "Vacuum Cylinder Replacement".
- 8 Remove the PDU retaining bracket assembly bolt (1).
- 9 Remove the PDU retaining bracket assembly (2).

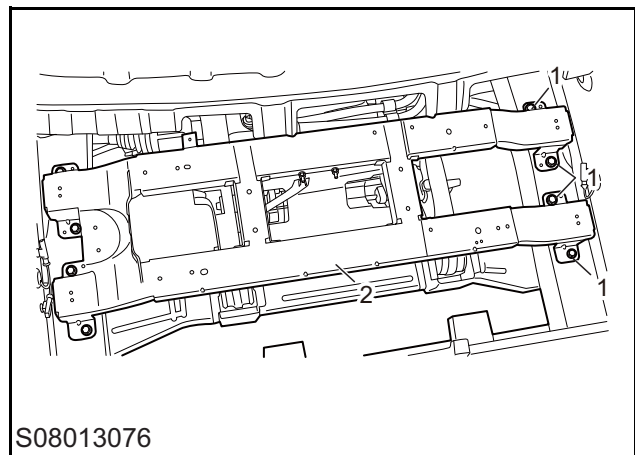

Installation

- 1 Install the PDU retaining bracket assembly.
- 2 Install the PDU retaining bracket assembly bolts, tighten them to 50 ± 5 Nm, and check the torque.
- 3 Install the vacuum cylinder retaining bolt. Refer to "Vacuum Cylinder Replacement".
- 4 Install the fuse box and its bracket.
- 5 Install the battery bracket. Refer to "Battery Bracket Replacement".
- 6 Install the charging and distribution unit. Refer to "Charging and Distribution Unit Replacement".
- 7 Refill the coolant. Refer to "Coolant Drain".

- 8 Install the manual service disconnect. Refer to "Manual Service Disconnect Replacement".
- 9 Disconnect the negative battery cable.

Brake System

Description and Operation

Electric Vacuum Assist Brake System

The vacuum sensor integrated in the vacuum tube assembly detects the vacuum in the vacuum booster all the time. The vacuum signal is transmitted to the VCU and when the VCU detects the vacuum in the vacuum booster is below the required range, it will control the electronic vacuum pump to turn on. The vacuum pump operates to extract air in the vacuum tube/vacuum cylinder and vacuum booster and increase the vacuum, until the vacuum in the vacuum booster reaches the required value. The vacuum pump stops working. Therefore, it can ensure sufficient boost when applying the brake pedal.

Operating voltage: 9 - 16V

Max. vacuum: -86kPa

Operating temperature: -40 - 120 °C

Heating, Ventilation and Air Conditioning

Specification

Fastener Specifications

Name	Torque (Nm)
Bolt - A/C Compressor	22 ± 2 Nm
Bolt - A/C Compressor Exhaust Pipe to Compressor Assembly	22 ± 2 Nm
Bolt - A/C Compressor Inlet Pipe to Compressor Assembly	22 ± 2 Nm
Bolt - A/C Compressor Exhaust Pipe to Condenser Assembly	9 ± 1 Nm
Bolt - Condenser Outlet Pipe Assembly to Condenser Assembly	9 ± 1 Nm
Bolt - Condenser Outlet Pipe Assembly Bracket	9 ± 1 Nm
Nut - Condenser Outlet Pipe Assembly	9 ± 1 Nm

Parameters

Compressor type	SHS-33H4203
Compressor displacement	33CC
Compressor voltage	
• Low voltage	12V DC
• High Voltage	400V DC
Compressor motor output power	2.4kW@5000rpm
Rotational speed of compressor	
• Minimum speed	800rpm
• Maximum speed	8500rpm
A/C lubricating oil type	SP-A2
Total lubricating oil filling level	120 ± 15g
Refrigerant type	R1234yf
Refrigerant charge	660 ± 20g
Evaporator temperature sensor	
• Compressor ON	4 °C
• Compressor OFF	1 °C
Pressure protection	
• High-pressure protection opening pressure	3.14Mpa
• Low-pressure protection opening pressure	0.19Mpa
PTC	5kW

Layout

Front A/C Layout

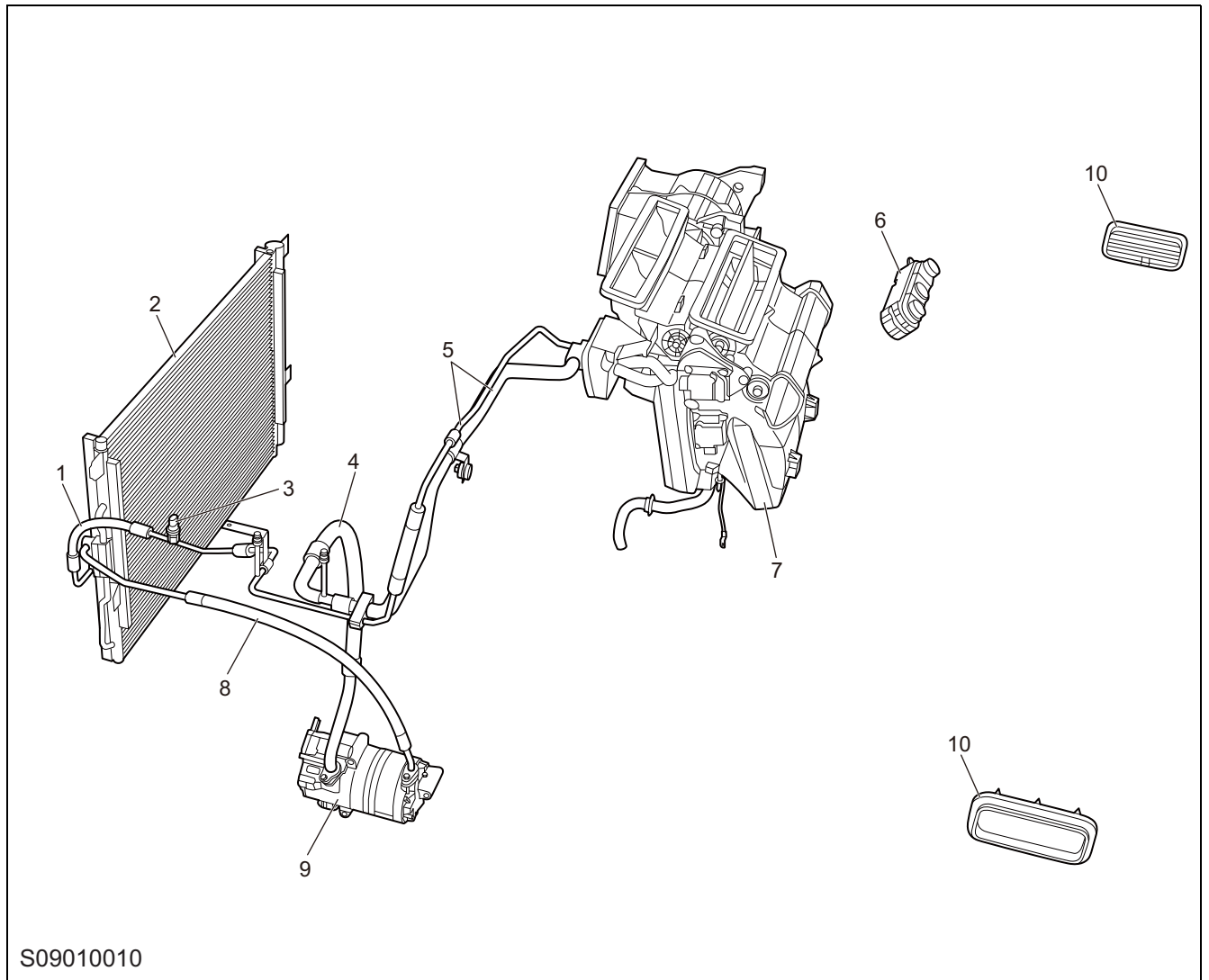

- | | | | |
|---|--------------------------------------|----|----------------------------------|
| 1 | Condenser outlet pipe assembly | 6 | Front A/C assembly |
| 2 | Condenser assembly | 7 | Front A/C control panel |
| 3 | Pressure/temperature sensor | 8 | A/C compressor assembly |
| 4 | Compressor inlet pipe assembly | 9 | Compressor exhaust pipe assembly |
| 5 | Front A/C inlet/outlet pipe assembly | 10 | Compartment air outlet assembly |

Heating, Ventilation and Air Conditioning

Service Guide

Refrigerant Drain and Refill

Drain

- 1 First connect 3 pipes onto the manifold gauge as required.
- 2 Respectively connect the red high-pressure pipe and blue low-pressure pipe onto the filling valves of A/C system.
- 3 Prepare one measuring cup, place the yellow intermediate pipe into the measuring cup and cover it with a clean cloth to prevent the refrigerant oil from spraying out.
- 4 Slowly turn on the blue and red knobs on the manifold gauge, and then refrigerant and refrigeration oil will flow out slowly.
- 5 After the refrigerant in the system is drained completely, tighten the high and low pressure knobs on the gauge, and remove the pipe.
- 6 The refrigeration oil drained out is sucked into the system in virtue of the vacuum in the system and manifold gauge after vacuuming the system.

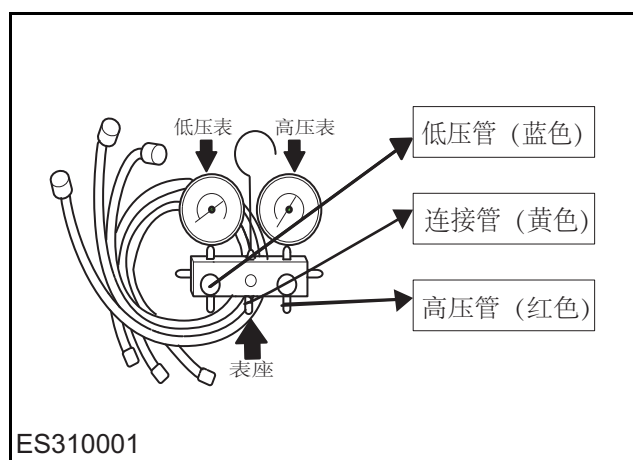

Refill

- 1 Confirm the system is vacuumed without leakage, connect the intermediate pipe connecting the manifold gauge to the vacuum pump to the joint of refrigerant tank.
- 2 Place the refrigerant tank on an electronic scale, open the refrigerant tank valve, and loosen the intermediate pipe on the manifold gauge to release air in the pipe. Do not tighten the joint until refrigerant flows out from the joint.
- 3 Check and record the weight on the electronic scale, turn on the high-voltage switch on the manifold gauge so that the refrigerant flows into

the A/C system, and then observe the weight on the electronic scale anytime.

- 4 When the filling amount reaches the specified weight, turn off the manifold gauge switch and subsequently the refrigerant tank valve switch.
- 5 Remove the manifold gauge, and filling is finished.

Caution:

High pressure: 3.14MPa

Low pressure: 0.196MPa

Medium pressure: 1.77MPa

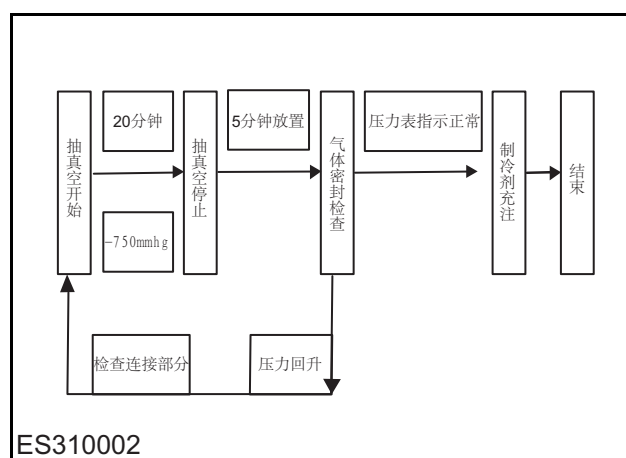

Refrigeration Oil Refill

Removal

- 1 Place the liquid filling machine flat on the work bench or fuel tank.

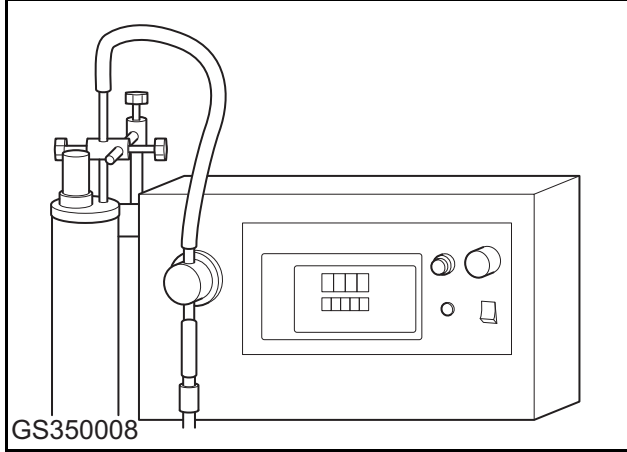

- 2 Open the hole plug with "IN" mark on the reservoir, fill the refrigeration oil (type: PAG), and for specific filling amount, see the table below. Press firmly the plug after filling, and this filling process should be completed within one minute.
- 3 Check the reservoir body for oil stain, if any, wipe clean the body.

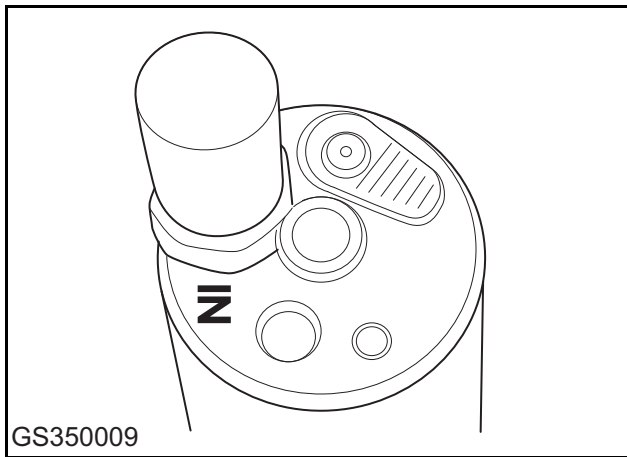

SN.	Replaced item	Filling amount (ml)
4	Evaporator replacement	50
5	Single pipe replacement	20
6	A/C Compressor Replacement	If the amount of residual oil that the compressor pours out is less than 30 ml, supplement 50 ml of refrigeration oil; If the amount is more than 30 ml, supplement the same oil amount to that of residual oil poured out.
7	Refrigerant recovery	Double A/C 50 ml; Single A/C 20ml.

SN.	Replaced item	Filling amount (ml)
1	Condenser replacement	30
2	Auxiliary condenser replacement	30
3	Dryer replacement	15

Heating, Ventilation and Air Conditioning

A/C Compressor Replacement

Removal

- 1 Disconnect the negative battery cable.
- 2 Remove the service switch. Refer to "Service Switch Replacement".
- 3 Recover the refrigerant.
- 4 Disconnect the A/C compressor high-voltage and low-voltage harnesses.
- 5 Remove the A/C compressor bolt (1).
- 6 Remove the A/C compressor (2).

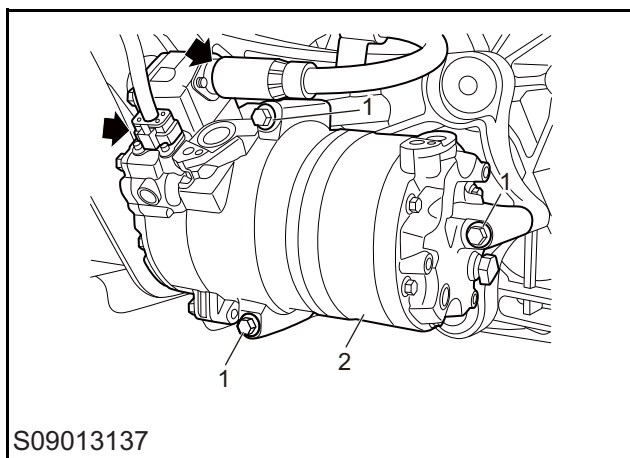

Installation

- 1 Install the A/C compressor.
- 2 Install 3 A/C compressor bolts, tighten them to 22 ± 2 Nm and check the torque.
- 3 Install the A/C compressor high-voltage and low-voltage harnesses.
- 4 Install the service switch. Refer to "Service Switch Replacement".
- 5 Refill the refrigerant.
- 6 Connect the negative battery cable.

Condenser Outlet Pipe Assembly Replacement

Removal

- 1 Disconnect the negative battery cable.
- 2 Remove the service switch. Refer to "Service Switch Replacement".
- 3 Recover the refrigerant.
- 4 Remove the radiator grille assembly.
- 5 Remove the front compartment fuse box assembly bracket.
- 6 Remove the A/C pressure sensor. Refer to "A/C Pressure Sensor Replacement".
- 7 Remove the condenser outlet pipe assembly nut (1).

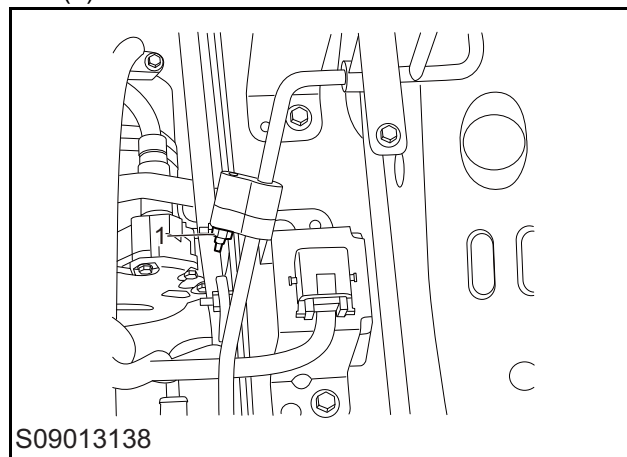

- 8 Remove the condenser outlet pipe assembly bolt (1).
- 9 Remove the condenser outlet pipe assembly (2).

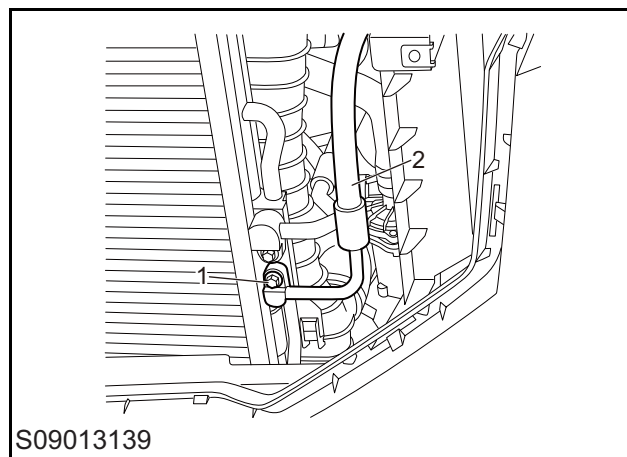

Installation

- 1 Install the condenser outlet pipe assembly.

- 2 Install the condenser outlet pipe assembly nut, tighten it to 9 ± 1 Nm and check the torque.
- 3 Install the condenser outlet pipe assembly bolt, tighten it to 9 ± 1 Nm and check the torque.
- 4 Install the front compartment fuse box assembly bracket.
- 5 Install the radiator grille assembly.
- 6 Install the A/C pressure sensor. Refer to "A/C Pressure Sensor Replacement".
- 7 Install the service switch. Refer to "Service Switch Replacement".
- 8 Refill the refrigerant.
- 9 Connect the negative battery cable.

Pressure Sensor Replacement

Removal

- 1 Disconnect the negative battery cable.
- 2 Recover the refrigerant.
- 3 Remove the front compartment fuse box assembly bracket.
- 4 Remove the pressure sensor harness.
- 5 Remove the pressure sensor (1).

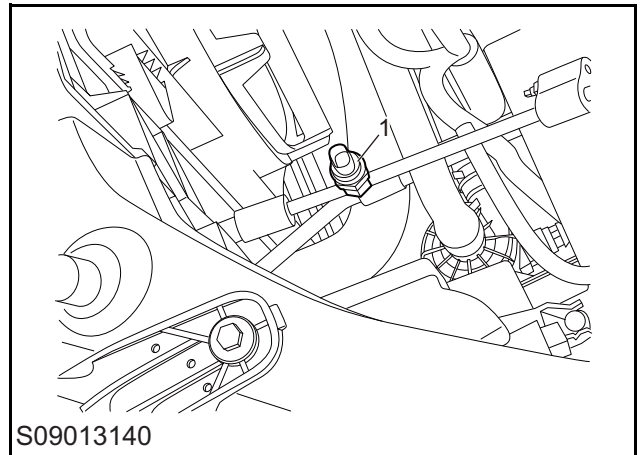

Installation

- 1 Install the pressure sensor.
- 2 Install the pressure sensor harness.
- 3 Install the front compartment fuse box assembly bracket.
- 4 Refill the refrigerant.
- 5 Connect the negative battery cable.

Heating, Ventilation and Air Conditioning

Compressor Inlet Pipe Assembly Replacement

Removal

- 1 Disconnect the negative battery cable.
- 2 Remove the service switch. Refer to "Service Switch Replacement".
- 3 Recover the refrigerant.
- 4 Remove the A/C compressor inlet pipe assembly bolt (1).
- 5 Remove the A/C compressor inlet pipe assembly from the A/C compressor.

- 2 Connect the harness clip.
- 3 Install the bolt - A/C compressor inlet pipe to compressor assembly, tighten it to 22 ± 2 Nm and check the torque.
- 4 Install the bolt - A/C compressor inlet pipe to condenser assembly, tighten it to 9 ± 1 Nm and check the torque.
- 5 Install the service switch. Refer to "Service Switch Replacement".
- 6 Refill the refrigerant.
- 7 Connect the negative battery cable.

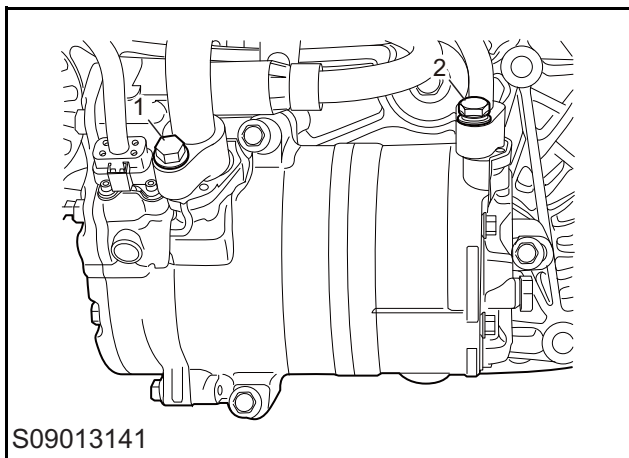

- 6 Remove the A/C compressor inlet pipe assembly bolt (1).
- 7 Disconnect the harness clip.
- 8 Remove the A/C compressor inlet pipe assembly (2).

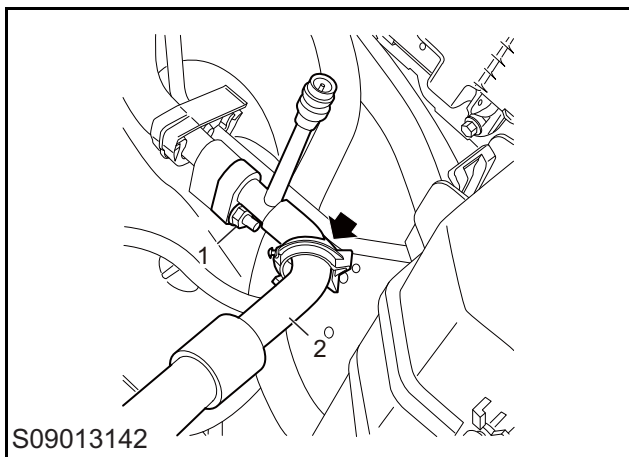

Installation

- 1 Install the A/C compressor inlet pipe assembly.

Compressor Exhaust Pipe Assembly Replacement

Removal

- 1 Disconnect the negative battery cable.
- 2 Remove the service switch. Refer to "Service Switch Replacement".
- 3 Recover the refrigerant.
- 4 Remove the radiator grille assembly.
- 5 Remove the A/C compressor exhaust pipe assembly bolt (2).
- 6 Remove the A/C compressor exhaust pipe assembly from the A/C compressor.

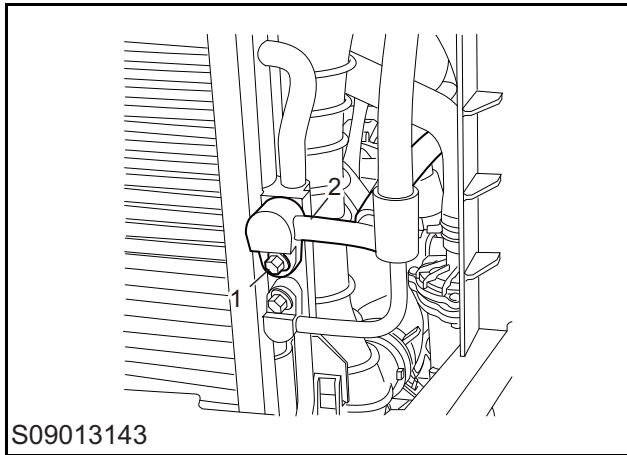

- 7 Remove the A/C compressor exhaust pipe assembly bolt (1).
- 8 Remove the A/C compressor exhaust pipe assembly (2).

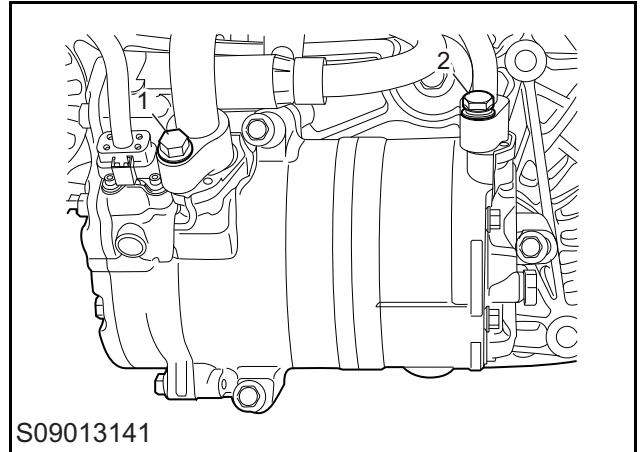

Installation

- 1 Install the A/C compressor exhaust pipe assembly.
- 2 Install the bolt - A/C compressor exhaust pipe to compressor assembly, tighten it to 22 ± 2 Nm and check the torque.
- 3 Install the bolt - A/C compressor exhaust pipe to the condenser assembly, tighten it to 9 ± 1 Nm and check the torque.
- 4 Install the radiator grille assembly.
- 5 Install the service switch. Refer to "Service Switch Replacement".
- 6 Refill the refrigerant.
- 7 Connect the negative battery cable.

Heating, Ventilation and Air Conditioning

Front A/C Inlet/Outlet Pipe Assembly Replacement

Removal

- 1 Disconnect the negative battery cable.
- 2 Remove the service switch. Refer to "Service Switch Replacement".
- 3 Recover the refrigerant.
- 4 Remove the front compartment fuse box assembly bracket.
- 5 Remove the bolt (1) - front A/C inlet/outlet pipe assembly to front A/C cabinet.
- 6 Remove the front A/C inlet/outlet pipe assembly bracket nut (2).
- 7 Remove the nut (3) connecting the front A/C inlet/outlet pipe assembly to the compressor inlet pipe assembly.
- 8 Remove the nut (4) connecting the front A/C inlet/outlet pipe assembly to the condenser outlet pipe assembly.
- 9 Remove the front A/C inlet/outlet pipe assembly (6).

- 4 Install the front A/C inlet/outlet pipe assembly bracket nut, tighten it to 9 ± 1 Nm and check the torque.
- 5 Install the bolt - front A/C inlet/outlet pipe assembly to front A/C cabinet, tighten it to 9 ± 1 Nm and check the torque.
- 6 Install the front compartment fuse box assembly bracket.
- 7 Install the service switch. Refer to "Service Switch Replacement".
- 8 Refill the refrigerant.
- 9 Connect the negative battery cable.

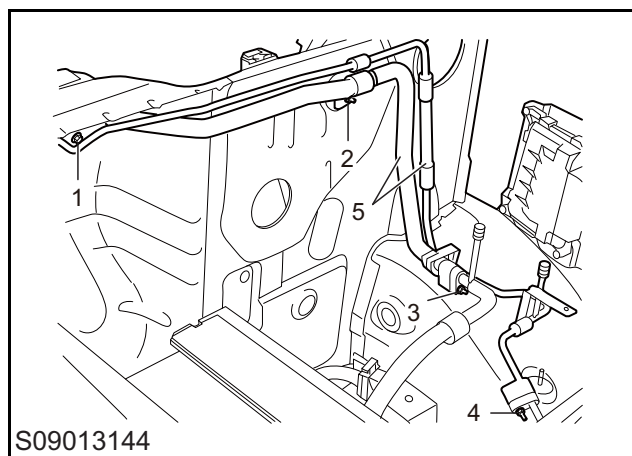

Installation

- 1 Install the front A/C inlet/outlet pipe assembly.
- 2 Install the nut connecting the front A/C inlet/outlet pipe assembly to the condenser outlet pipe assembly, tighten it to 9 ± 1 Nm and check the torque.
- 3 Install the nut connecting the front A/C inlet/outlet pipe assembly to the compressor inlet pipe assembly, tighten it to 9 ± 1 Nm and check the torque.

Front A/C Assembly Replacement

Removal

- 1 Disconnect the negative battery cable.
- 2 Recover the A/C system refrigerant. Refer to "Refrigerant Drain and Refill".
- 3 Remove the bolt fixing the A/C pipe assembly to the expansion valve, and disconnect the pipe.
- 4 Remove the A/C heater inlet/outlet hose of the front A/C.
- 5 Disconnect the front A/C assembly harness.
- 6 Remove the nut (1) - front A/C assembly to dash panel subassembly.

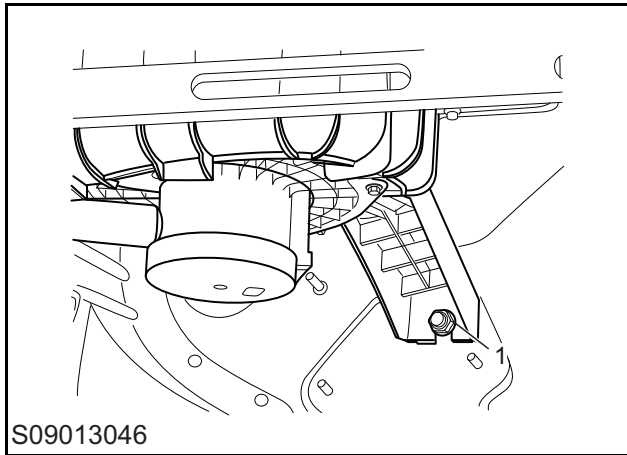

- 7 Remove the instrument panel beam. Refer to "Instrument Panel Beam Replacement".
- 8 Remove 4 bolts (1) - front A/C assembly to instrument panel beam.

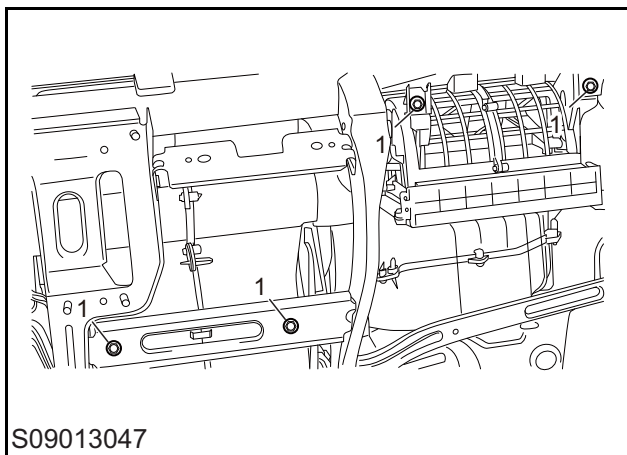

- 9 Remove 2 nuts (1) - front A/C assembly to instrument panel beam.

- 10 Remove the front A/C assembly (2).

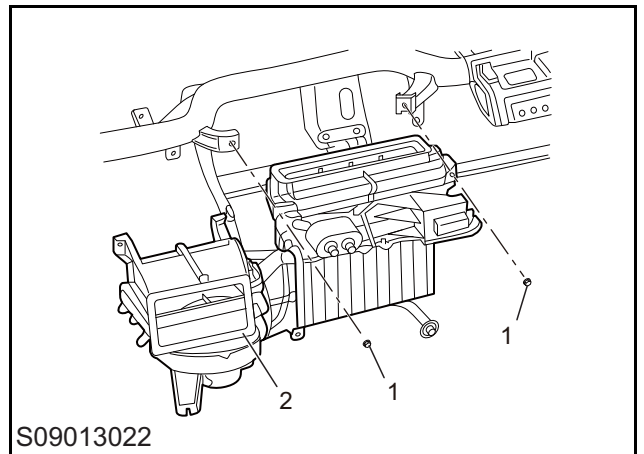

Installation

- 1 Install the front A/C assembly.
- 2 Install the nut - front A/C assembly to instrument panel beam, tighten it to 9 ± 1 Nm and check the torque.
- 3 Install the bolt - front A/C assembly to instrument panel beam, tighten it to 9 ± 1 Nm and check the torque.
- 4 Install the instrument panel beam. Refer to "Instrument Panel Beam Replacement".
- 5 Install the nut - front A/C assembly to dash panel subassembly, tighten it to 9 ± 1 Nm and check the torque.
- 6 Connect the front A/C assembly harness.
- 7 Fix the A/C pipe assembly to the expansion valve.
- 8 Install the A/C heater inlet/outlet hose of the front A/C.
- 9 Refill the A/C system refrigerant. Refer to "Refrigerant Drain and Refill".
- 10 Connect the negative battery cable.

Heating, Ventilation and Air Conditioning

Front A/C Control Panel Replacement

Removal

- 1 Remove the center console lower panel. Refer to "Center Console Lower Panel Replacement".
- 2 Remove 4 front A/C control panel bolts (1).
- 3 Remove the front A/C control panel (2).

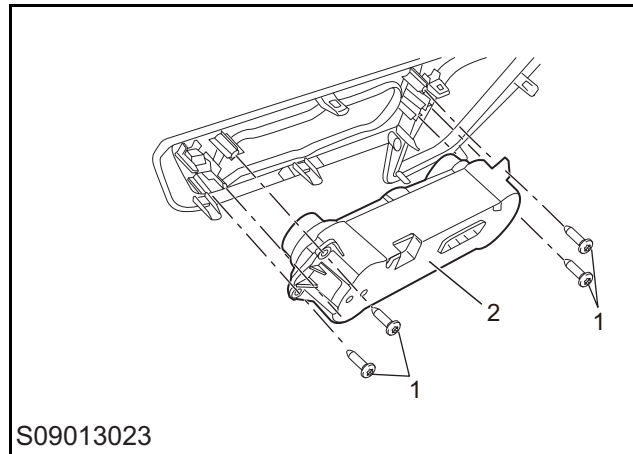

Installation

- 1 Install the front A/C control panel.
- 2 Install the front A/C control panel bolts, tighten them to 1.2 ± 0.2 Nm and check the torque.
- 3 Install the center console lower panel. Refer to "Center Console Lower Panel Replacement".

Condenser Assembly Replacement

Removal

- 1 Remove the cooling module assembly. Refer to "Cooling Module Assembly Replacement".

Installation

- 2 Install the cooling module assembly. Refer to "Cooling Module Assembly Replacement".

Compartment Air Outlet Assembly Replacement (Van-type Truck)

Removal

- 1 Remove the rear bumper side panel assembly. Refer to "Rear Bumper Side Panel Assembly Replacement".
- 2 Remove the compartment air outlet assembly (1).

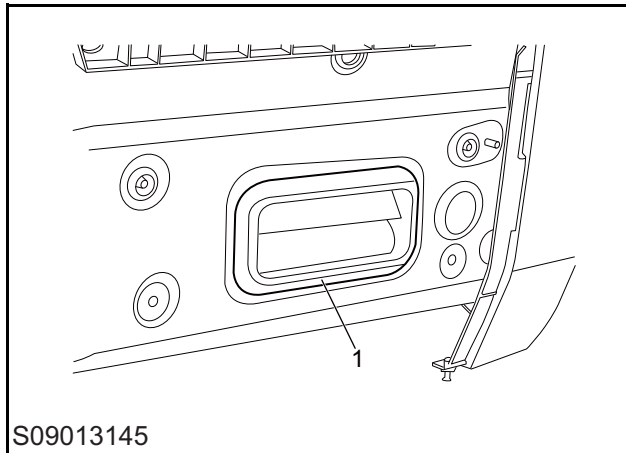

Installation

- 1 Install the rear bumper side panel assembly. Refer to "Rear Bumper Side Panel Assembly Replacement".
- 2 Install the compartment air outlet assembly.

Compartment Air Outlet Cover Plate Assembly Replacement (Chassis Truck)

Removal

- 1 Gently pry off the vehicle air outlet cover plate with plastic crowbar.

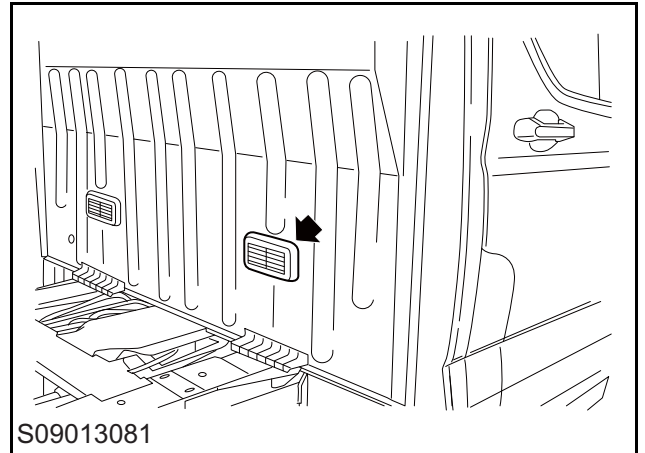

- 2 Remove the vehicle air outlet cover plate assembly from the vehicle.

Installation

- 1 Fix the vehicle air outlet assembly to the vehicle, and tighten them.

Heating, Ventilation and Air Conditioning

Compartment Air Outlet Assembly Replacement (Chassis Truck)

Removal

- 1 Remove the vehicle air outlet cover plate assembly.
- 2 Move the front seats forward.
- 3 Pry off and remove the vehicle air outlet assembly with a tool.

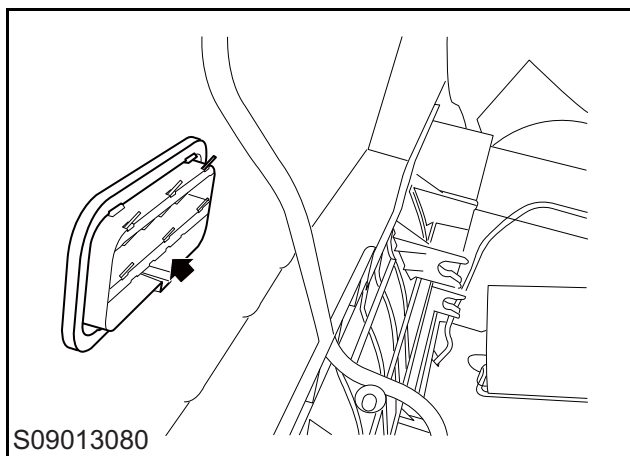

Installation

- 1 Fix the vehicle front air outlet assembly to the vehicle, and tighten them.
- 2 Reset the front seats.
- 3 Install the vehicle air outlet cover plate assembly.

Electric Heater Replacement

Removal

- 1 Disconnect the negative battery cable.
- 2 Disconnect the service switch. Refer to "service switch replacement".
- 3 Remove the instrument panel crossbeam. Refer to "instrument panel beam replacement".
- 4 Remove the driver side outlet duct.
- 5 Disconnect the electrical connector of the electric heater.
- 6 Remove the electric heater harness fixing screw (1).
- 7 Remove the electric heater fixing screw (2).
- 8 Remove the electric heater (3).

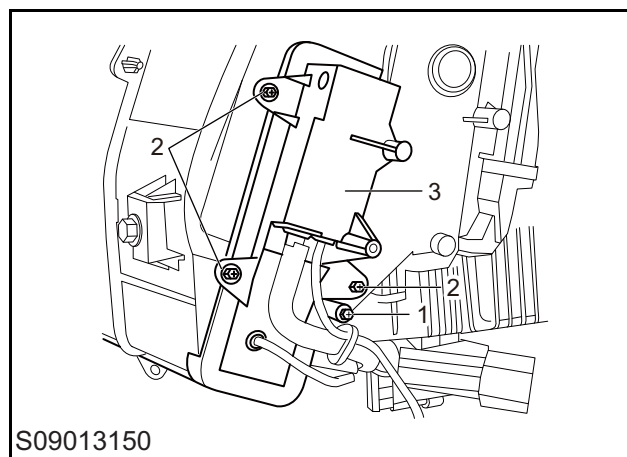

Installation

- 1 Install the electric heater.
- 2 Install the fixing screw of electric heater and check the torque.
- 3 Install the fixing screw of electric heater harness and check the torque.
- 4 Connect the electric connector of electric heater.
- 5 Install the driver side air outlet duct.
- 6 Install the instrument panel beam. Refer to "instrument panel beam replacement".
- 7 Install service switch. Refer to "service switch replacement".
- 8 Connect the negative battery cable.