

OWNER'S MANUAL

KORANDO



Recommended Fluids and Lubricants

Category		Capacity	Specifications
Coolant	Heater cabin coolant	LHD	≐ 1.9 ℓ KG Mobility genuine coolant Anti-Freeze: SYC-1025 (LLC)
		RHD	≐ 1.7 ℓ Anti-Freeze: Water = 50:50
	High voltage battery coolant		≐ 7.1 ℓ KG Mobility genuine coolant Anti-Freeze: SYC-306E Anti-Freeze: Water = 50:50
	Drive motor coolant	H/P	≐ 5.1 ℓ KG Mobility genuine coolant Anti-Freeze: SYC-1025 (LLC)
Non H/P		≐ 5.0 ℓ Anti-Freeze: Water = 50:50	
Brake fluid		As required	KG Mobility genuine oil (DOT4)
Decelerator		≐ 1.3 ℓ	Castril BOT384 (Recommended), Castrol ON D2

Warning

- Use only KG Mobility recommended fluids and lubricants.
- Do not mix any different types or brands of oils or fluids. This may cause damages.
- Keep the specified levels when adding or replacing the fluids.

Foreword

This section provides useful information to know in advance for reading the owner's manual.

Information regarding the marks used in the owner's manual, change of car design, and periodic check is provided.

Thank you for purchasing the KORANDO e-motion.

KORANDO e-motion you selected is a vehicle with superior safety and quality and the latest technologies. KG Mobility Corporation has been carrying out and initiating R&D activities continuously in the industry.

Please read this owner's manual carefully before driving the KORANDO e-motion. You can drive safely and economically by utilizing the technical advantages applied to the vehicle.

We will dedicate ourselves to ensure that you can always drive the KORANDO e-motion pleasantly and safely.



Purpose and Application Conditions of the Owner's manual

This owner's manual has been prepared to provide information for the specifications and functions of the vehicle, and important safety information including cautions and warnings for safe driving and correct vehicle maintenance.

- All descriptions, pictures, and drawings included in this owner's manual are based on the time of the document's preparation. If there is a change in the specifications (options) and functions according to a change of design, some content may be different from the actual vehicle.
- This owner's manual has been prepared based on all specifications (options) of the vehicle. Please understand that an explanation of a specification (options) which is not provided for your vehicle may be provided.

As some options or option packages may be added or deleted randomly depending on the vehicle point of sale and design changes, make sure that the options you applied when signing the contract are fitted to your vehicle prior to reading this owner's manual.

Please read this owner's manual carefully before driving the vehicle, to ensure safe driving and the best vehicle performance.

Open Source Software Notice Information

To obtain the source code under GPL, LGPL, MPL, and other open source licenses, that is contained in this product, please visit <http://opensource.lge.com>.

In addition to the source code, all referred license terms, warranty disclaimers and copyright notices are available for download.

LG Electronics will also provide open source code to you on CD-ROM for a charge covering the cost of performing such distribution (such as the cost of media, shipping, and handling) upon email request to opensource@lge.com.

This offer is valid for a period of three years after our last shipment of this product. This offer is valid to anyone in receipt of this information.

Marks Used in this Owner's manual

DANGER

It indicates a dangerous situation (DANGER) that may likely lead to death or serious injury.

It should be observed for the safety of the driver and other passengers.

WARNING

It indicates a dangerous situation (WARNING) that may lead to death or serious injury.

It should be observed for the safety of the driver and other passengers.

CAUTION

It indicates a dangerous situation (CAUTION) that may lead to moderate or minor injury, or a situation that may lead to damage to the vehicle.

It should be observed for the safety of the driver and other passengers and the prevention of property damage.

NOTICE

It is used for explaining additional information or procedures related to the vehicle and driving.



It is used to indicate the location of relevant information useful for using the product.

Change of Specifications (options) and Functions According to a Change of Design

The design is subject to change without prior notice for improving the safety and performance of the vehicle. Therefore, a vehicle specification (options) may be added or deleted, or a function may change.

The content explained in this owner's manual may be different from your vehicle.

Do Not Use Vehicle Components for Other Purposes

Do not use vehicle components for other purposes. KG Mobility Corporation is not liable for any consequent damages.

Importance of a Periodic Check

Have your vehicle checked and maintained at a prescribed period in order to maintain the performance of the vehicle and to prevent the reduction of its life.

Information for Using KG Mobility Authorized Service Center

KG Mobility Corporation is not liable for any problem that occurred due to maintenance carried out by a service center other than KG Mobility Authorized Service Center.

Table of Contents

The table of contents is provided in three types to allow you to find necessary information in a convenient method easily and fast.

- Introduction to chapters - You can identify the content of each chapter at a glance.
- Detailed table of contents - You can find desired information using a name through the detailed title for the relevant chapter.
- Table of pictures - You can find desired information using a picture easily even if you do not know the title of the desired information.

Introduction to Chapters

Identify the contents of each chapter at a glance.

Foreword

- You can check information regarding the marks used in the instruction manual, change of car design, and periodic check.

1. Vehicle Information and Safety Precautions

- You can check helpful information for driving and managing the vehicle safely and conveniently.
- Information regarding the vehicle identification, specifications, check points before driving the vehicle, safety precautions while driving, and vehicle maintenance methods is provided.

2. Safety Units

- You can check information regarding devices that allow you to drive the vehicle safely and how to use such devices.
- An explanation is provided for seat belts, a baby car seat, airbags, anti-theft, and warning system.

3. Convenient Equipment

- You can check information regarding devices that allow you to drive the vehicle conveniently and usefully and how to use such devices.
- An explanation is provided for doors, seats, windows, as well as various convenient equipment including the tailgate, various lights and lamps, mirrors, heater and A/C, AV navigation, storage and cargo box.

4. Starting and driving

- You can check information regarding the basic auxiliaries for safe driving, auxiliary equipment that helps you to drive comfortably, and how to use such equipment.
- You can see a description of the driving controls such as instrument cluster, electronic shift lever, four-wheel drive, cruise control including ignition switch and smart key, as well as driving assistance devices such as brake and emergency braking assistance (AEB), blind spot detection warning system, lane keeping assistance, and parking distance warning.

5. Emergency Measures in the Event of Emergency

- You can check useful information and emergency measures for various emergency situations you can face while driving.
- Information regarding the warning triangle and OVM tools, and a correct measure in case of a dead battery, flat tire, and towing a vehicle is provided. An explanation is also provided for how to respond to a fire, heavy snow, vehicle trouble, and an accident safely.

6. Periodic Checking and Maintenance

- You can check the necessary periodic check and maintenance methods in detail for safe and pleasant vehicle driving.

Index

- You can find important functions or terms from the content of this instruction manual in alphabetical order conveniently.

Detailed Table of Contents

Find the desired information using a name through detailed titles.

1. Vehicle Information and Safety Precautions			
Information regarding the installation of ADR and provision of information	1-2	Lift and mounting points	1-11
Precautions for potentially hazardous seat belt related goods	1-3	Stationary vehicle (OFF)	1-11
Precautions for the reduction of non-crash incidents	1-4	To turn ignition off	1-11
Cautions for the protection of the environment	1-5	To turn ignition off while driving (in case of emergency)	1-12
KORANDO e-motion	1-6	Safety precautions for electric vehicle.....	1-12
Battery.....	1-7	Safety plug.....	1-12
400 V drive battery	1-7	Safety interlock connector	1-12
High voltage (drive) battery.....	1-7	To cutoff power from high voltage battery	1-13
12 V battery.....	1-8	Safety plug.....	1-13
400 volts electrical circuit.....	1-8	Safety interlock connector	1-14
Driving.....	1-8	To cutoff power from low voltage (12 V) battery	1-15
Features	1-8	OVM tools	1-15
Noise	1-9	Location where the OVM tools are stored.....	1-15
Emergency measures in case of emergency	1-10	When towing truck unavailable (in an emergency)	1-16
To change P (park) position	1-10	To fit towing hook.....	1-16
Double parking (2-row parking)	1-10	Cautions	1-17
		Warning	1-17
		In the event of an impact on underside of vehicle or such an accident.....	1-17
		In case of fire.....	1-17
		Towing.....	1-17
		Vehicle washing	1-17
		Certification	1-18
		Vehicle identification	1-20
		Manufacturer's plate.....	1-20
		Vehicle Identification Number (VIN).....	1-20
		Visual Vin Label	1-20
		Dimensions	1-21
		Front	1-21
		Rear.....	1-21
		Top	1-21
		Side	1-21
		SPECIFICATIONS.....	1-22
		Precautions for the modification of the vehicle and structural alteration	1-23
		Checking before driving	1-25
		Daily inspection	1-25
		Checking motor room	1-25
		Checking coolant.....	1-25
		Checking brake fluid	1-25
		Checking washer fluid	1-26
		Checking tires	1-26
		Checking the instrument cluster	1-27

Checking the parking brake	1-27	No sudden starting, acceleration or braking	1-33	Vehicle management	1-38
Checking the pedals	1-28	Driving on unpaved and mountain roads	1-33	KG Mobility Authorized Service Center and maintenance partners	1-38
Cleaning up near the driver's seat	1-28	In high mountain area	1-34	Cautions for the depletion of battery when connecting uninterruptible power supply to the black box system	1-38
Advisable driving position	1-28	Driving on a snowy or icy road	1-34	Breaking in a new vehicle correctly ..	1-38
Adjusting the seat, headrest, steering wheel, and mirrors	1-28	Driving on a sandy or muddy road ...	1-34	Long-term parking mode	1-38
Wearing the seat belt correctly	1-29	Driving on a hillside road and downhill road	1-34	Using genuine parts	1-38
Safety and cautions for driving ...	1-30	Driving on a road with a pool of water or a river	1-35	Vehicle washing	1-39
No drugged, drunk, distracted and drowsy (4D) driving	1-30	Do not use a cellular phone or watch DMB while driving	1-35	Washing the bumper	1-40
Precautions for infants, children, old people, or pregnant women	1-31	Driving on the expressway	1-35	Washing wheels	1-40
An infant or a small child must be seated in the rear seat with protective gear	1-31	Crossing an intersection or railroad crossing	1-35	Cautions for polishing the vehicle	1-40
No sleeping in a sealed vehicle	1-31	No sudden maneuvering of the steering wheel	1-36	Cleaning and maintaining glass	1-41
Do not drive with the doors or tailgate open	1-32	To use regenerative braking	1-36	Cautions for window tinting	1-41
Do not hold a part of your body out of the window or sunroof	1-32	Cautions for attaching accessories ...	1-36	Care and cleaning of the interior	1-41
Be careful not to have a part of your body caught when using the power window	1-32	Special cautions when checking the coolant	1-36	Seat Belt Care	1-42
Check for any vehicles or persons passing by when getting out	1-33	Do not load hazardous materials	1-36	Cautions for using the vehicle key	1-42
Safe parking and stopping	1-33	Cautions for vehicle ventilation	1-37	Corrosion protection	1-42
Do not stop the vehicle while driving.	1-33	System protection function (delayed accelerator pedal response)	1-37	Sheet Metal Damage	1-42
		Placement of extinguisher	1-37	Foreign Material Deposits	1-42
				Finish Damage	1-43
				Underbody Maintenance	1-43
				High voltage warning lamp	1-44
				Other maintenance	1-44

2. Safety Units

Seat belt	2-2
Seat belt warning.....	2-2
Front seat (driver / passenger) belt reminder	2-3
Rear seat (left / center / right) belt reminder*	2-3
Fastening the seat belt	2-4
Unfastening the seat belt	2-5
Managing the seat belt	2-5
Adjusting the height of the front seat belt	2-5
Rear seat belt storage	2-5
Rear seat buckle storage	2-5
Rear center seat belt storage.....	2-6
Rear center seat belt release	2-6
How to fasten the seat belts (2-point) in rear center seat.....	2-6
How to fasten the seat belt (3-point) in rear center seat	2-7
Seat belt pretensioner and load limiter	2-8
Pretensioner.....	2-8
Load limiter	2-8
Fastening the seat belt by a pregnant woman	2-9

Warnings for the seat belt.....	2-9
Child restraint for an infant or a small child	2-11
Infant and child safety.....	2-12
Child Seat	2-12
Table of Vehicle Handbook Information on Child Restraint Systems Installation Suitability for Various Seating Positions	2-12
Table of Vehicle Handbook Information on ISOFIX Child Restraint Systems Installation Suitability for Various ISOFIX Positions.....	2-13
Table of Vehicle Handbook Information for Installation in Various Seating Positions on i-Size Child Restraint Systems	2-14
List of suitable universal Child Restraint Systems (CRS).....	2-14
List of suitable ISOFIX Child Restraint Systems (CRS).....	2-14
List of suitable i-Size Child Restraint Systems (CRS).....	2-14
Installation of crs secured by the seatbelt.....	2-15
Front-facing Child Seat	2-15
Rear-facing Child Seat	2-15

Securing a child restraint system with “ISOFIX/i-Size” system and “Tether Anchorage” system*	2-17
Locations of ISOFIX/i-Size Lower Anchors and Top Tether.....	2-17
How to use ISOFIX/i-Size Lower Anchor	2-17
How to use Top Tether.....	2-18
Warning For Child Restraint	2-19
Air bag*	2-20
Air bag warning label.....	2-20
Air bag warning lamp.....	2-20
Air bag crash sensor and air bag control module	2-21
Configuration of air bag.....	2-21
Passenger Air Bag ON/OFF Switch*	2-21
Driver air bag.....	2-22
Driver knee air bag	2-22
Front passenger air bag.....	2-22
Front seat side air bag.....	2-23
Front center side air bag*	2-23
Curtain air bag	2-23
Cases where the air bag does not inflate	2-24
In the event of a slight collision....	2-24

In the event of a rear end collision	2-24
In the event of a side collision	2-25
In the event of a diagonal collision	2-25
In the event of a collision with a narrow object.....	2-25
In case the vehicle moves beneath another vehicle	2-26
In the event of a rollover accident.....	2-26
Secondary injury due to air bag deployment	2-26
Other cases.....	2-27
Cases where the driver/front passenger air bags do not inflate.....	2-27
Cases where the side air bags or curtain air bags do not inflate.....	2-27
Warnings for the air bag.....	2-27

Tire pressure monitoring system (TPMS)..... **2-29**

Checking the tire pressure.....	2-29
If the tire pressure or the TPMS is abnormal	2-30
Display of the TPMS status on the instrument cluster	2-31

When low tire pressure is detected ..	2-33
When you have rotated the tires.....	2-33
Cautions for the TPMS	2-34

Anti-theft and warning system **2-35**

Immobilizer system*	2-35
Immobilizer/smart key warning light.....	2-35
If the vehicle does not start.....	2-36
When the transponder is damaged	2-36
When you lose the key	2-36
Theft deterrent system.....	2-37
Entering the theft monitoring mode	2-37
Activating the theft alarm.....	2-38
Holding the theft alarm	2-38
Canceling the theft monitoring mode	2-38

3. Convenient Equipment

Door **3-2**

Locking, unlocking and opening the door	3-2
Door lock/unlock lever	3-2
Door open lever	3-2
Door Lock/Unlock button	3-2

Auto door lock function at the time of driving	3-3
--	-----

Auto door unlock function at the time of collision	3-3
--	-----

Child safety door lock	3-4
Locking/unlocking the door lock	3-4

Seat **3-5**

Seat & adjustment switch / button / lever.....	3-5
--	-----

Front seat.....	3-6
-----------------	-----

Adjusting the headrest.....	3-6
-----------------------------	-----

Adjusting the front and rear angles.....	3-6
--	-----

Adjusting the height	3-6
----------------------------	-----

Separation/installation.....	3-7
------------------------------	-----

Adjusting the power seat*	3-7
---------------------------------	-----

Front and rear position adjustment (driver seat/front passenger seat).....	3-7
--	-----

Adjusting the height (driver seat/ front passenger seat).....	3-8
---	-----

Adjusting the cushion angle (driver seat/front passenger seat)	3-8
--	-----

Adjusting the backrest angle (driver seat/front passenger seat)	3-8
---	-----

Adjusting the lumbar support (driver seat).....	3-9	Window (power window)*	3-17	Tailgate	3-24
Adjusting the seat manually.....	3-10	Opening the driver seat/front passenger seat window	3-17	Manual tailgate.....	3-24
Front and rear position adjustment (driver seat/front passenger seat)	3-10	Closing the driver seat/front passenger seat window	3-17	Opening	3-24
Adjusting the backrest angle (driver seat/front passenger seat)	3-10	Driver seat window safety function	3-18	Closing	3-24
Adjusting the height (driver seat)	3-10	Opening/closing the rear seat window.....	3-18	Power tailgate*	3-25
Rear seat	3-11	Rear seat window lock function...	3-19	Opening/closing with the driver seat's button	3-25
Adjusting the height of the headrest	3-11	Sunroof*	3-20	Opening/closing with the smart key	3-26
Seatback reclining adjustment	3-11	Opening automatically.....	3-21	Opening/closing with the button on the tailgate	3-26
Rear seat backrest folding.....	3-12	Opening manually	3-21	Anti-pinch protection function.....	3-27
Seat ventilation and heating*	3-13	Closing automatically	3-21	Resetting the opening height	3-27
Front seat ventilation and heating*	3-13	Closing manually.....	3-21	Resetting the power tailgate	3-27
Front seat ventilation.....	3-13	Tilting the sunroof up/down.....	3-22	Smart tailgate*	3-28
Front seat heating	3-14	Tilting up (opening the rear section)	3-22	Activating/deactivating the smart tailgate	3-28
Smart front seat heating control.....	3-14	Tilting down (closing the rear section)	3-22	Opening the smart tailgate	3-29
Rear seat heating*	3-15	Sunroof open warning	3-22	Operating condition	3-29
Rear seat heating smart control.....	3-15	Sunroof safety function	3-22	Operation step.....	3-29
Warnings and cautions related to the seats	3-16	Resetting the sunroof	3-23	Stopping the smart tailgate function	3-29
		Cases requiring the resetting of the sunroof.....	3-23	Opening the tailgate in the event of emergency	3-30
		Resetting	3-23	Motor room hood.....	3-32
				Opening the motor room hood	3-32
				Closing the motor room hood.....	3-33

Checking before closing the motor room hood	3-33	Operating status and faults of control box	3-46	Turning on the high beam and low beam at the same time (passing light)	3-57
Closing motor room hood	3-33	Charging procedures	3-48	Hazard warning lamp	3-57
EV charge port door	3-34	After completing charging	3-51	Adjusting the angle of the head light	3-58
Opening EV charge port door	3-34	How to store and care for slow charging cable	3-53	Angle adjustment levels of the head light	3-58
Closing EV charge port door	3-34	Scheduled charging	3-54	Angle adjustment standard for the head light	3-59
Charging type and precautions	3-35	How to perform scheduled charging	3-54	Daytime Running Light (DRL)*	3-59
Slow charging	3-35	To charge immediately after canceling scheduled charging	3-54	In case the DRL turns on	3-59
Fast charging	3-35	Lights and lamps	3-55	In case the DRL turns off	3-60
Portable charger	3-36	Outdoor lights/lamps	3-55	Smart High Beam (SHB)*	3-60
Connecting and disconnecting of charging connector	3-38	Light switch	3-56	Setting the SHB	3-60
Connecting charging connector	3-38	Turning on the head light	3-56	In case the high beam turns on	3-61
Disconnecting charging connector ...	3-38	Turning on the tail light	3-56	In case the high beam turns off	3-61
Emergency removal of charging connector	3-39	Activating the auto light function*	3-56	Operating the Light switch	3-61
Charging connector lock	3-40	Turning off all lights	3-56	Welcome light	3-62
Locking charging connector	3-40	Turning on the front fog light*	3-56	Welcome mode	3-62
Charging indicator	3-41	Turning on the rear fog light*	3-56	Goodbye mode	3-62
Slow and fast charging	3-42	Turning off the fog light*	3-56	In case the auto approach lamp turns off	3-62
Charging procedures	3-42	Turning on/off the left/right turn signal	3-56	Coming home/living home light	3-63
After completing charging	3-44	Turning on/off the high beam	3-57	Setting the coming home/living home light	3-63
Portable charger	3-46				

Operating the coming home light	3-63	Wiper and washer fluid.....	3-73	Manual Day/Night Adjustment.....	3-77
Operating the living home light	3-63	Windshield wiper	3-73	Heater and air conditioner	3-78
Auto light function*	3-64	Adjusting the operation speed of the windshield wiper.....	3-73	Adjusting the direction of air distribution and blocking the air distribution	3-78
Auto light sensor	3-64	Front windshield and washer fluid linkage	3-73	Cautions for using the heater and air conditioner	3-79
Interior lamp	3-65	Front auto washer	3-73	Replacing A/C refrigerant/oil	3-79
Front room lamp (overhead console).....	3-66	Rear window wiper	3-74	Heater and A/C controller	3-81
Driver seat spot switch	3-66	Rear window wiper washer fluid linkage function	3-74	Turning on/off the heater and the air conditioner	3-82
Front passenger seat spot switch	3-66	Rain sensing wiper*	3-74	Adjusting the temperature of the driver seat and the front passenger seat	3-82
Door linkage switch	3-66	Rain sensor.....	3-74	Adjusting the temperature of the driver seat and the front passenger seat (independent operation)	3-82
SOS switch*	3-66	Mirror.....	3-75	Synchronizing based on the driver seat set temperature (SYNC)	3-82
Linkage function between the smart/rokes key and the front room lamp	3-67	Outside rearview mirror.....	3-75	Auto mode	3-83
Center room lamp	3-67	Folding/unfolding the outside rearview mirror.....	3-75	Manual mode	3-83
Luggage room lamp.....	3-67	Auto folding/unfolding function	3-75	Selecting the direction of air distribution	3-84
Sun visor/mirror lamp	3-68	Adjusting the outside rearview mirror	3-75	Operating the glass heater	3-84
e-call (Emergency call)*	3-68	Selecting the outside rearview mirror	3-75	Removing moisture on the glass	3-85
How to use E-CALL system	3-69	Adjusting the angle of the outside rearview mirror	3-76		
e-call can't be canceled when:.....	3-70	Interior mirror	3-76		
Glove box lamp.....	3-72	ECM room mirror*	3-76		
Mood lamp*.....	3-72	Manual type inside rearview mirror...	3-77		
Mood lamp setting.....	3-72				

Auto defogger system	3-86	Power socket	3-93	Adjusting the position of the luggage upper cover	3-103
Activating/deactivating the auto defogger system	3-86	AC inverter*	3-94	How to store luggage upper cover.....	3-104
Operation levels of auto defogger system	3-86	Operating the AC inverter.....	3-94	Luggage compartment board.....	3-104
Heating mode switch.....	3-86	Indoor convenient equipment	3-96	Luggage net	3-105
Solar radiation sensor	3-87	Sun visor and card holder (driver seat)	3-96	Roof rack*	3-106
Steering wheel	3-88	Sun visor	3-96		
Adjusting the height/length of the steering wheel.....	3-88	Card holder	3-96		
Steering wheel heater*	3-88	Mirror and lamp	3-96		
Horn.....	3-88	Grip handle/coat hanger	3-97		
Infotainment system	3-89	Storage unit	3-98		
Smart audio*.....	3-89	Front seat/rear seat cup holder.....	3-98	START/STOP switch (Smart key)*	4-2
AV/Navigation*	3-90	Front storage (W/O WPC).....	3-98	OFF status	4-2
Slots for multimedia.....	3-91	Sunglass holder	3-99	ACC status.....	4-2
Operating from the steering wheel ...	3-91	Glove box	3-99	ON status.....	4-2
Voice recognition function	3-91	Console	3-100	READY status.....	4-2
Controlling the volume.....	3-91	Door map pocket.....	3-100	To start vehicle	4-3
Bluetooth hands-free.....	3-91	Seat backrest pocket.....	3-101	To start vehicle.....	4-3
Mute	3-91	Wireless Phone Charger System* ..	3-101	Getting your vehicle started	4-3
Selecting the mode.....	3-92	To Charge Phone	3-101	When vehicle does not start.....	4-4
Searching for media (SEEK)	3-92	Additional equipment in the luggage compartment*	3-103	Starting the vehicle with the dead smart key or interference, etc. (in the event of emergency)	4-4
Antenna (GPS, radio, DAB (EU), GSM (E-call)).....	3-92	Luggage upper cover	3-103	To start vehicle when stop lamp fuse fails (emergency).....	4-4
		Installing the luggage upper cover.....	3-103	Stopping the vehicle.....	4-5

4. Starting and driving

START/STOP switch (Smart key)*	4-2
OFF status	4-2
ACC status.....	4-2
ON status.....	4-2
READY status.....	4-2
To start vehicle	4-3
To start vehicle.....	4-3
Getting your vehicle started	4-3
When vehicle does not start.....	4-4
Starting the vehicle with the dead smart key or interference, etc. (in the event of emergency)	4-4
To start vehicle when stop lamp fuse fails (emergency).....	4-4
Stopping the vehicle.....	4-5

Stopping the vehicle while driving (in the event of emergency)	4-5	To unlock with door handle switch (when the safety unlock is disabled).....	4-11	Seat belt warning lamp	4-21
Cautions for using the START/STOP switch	4-6	To unlock with door handle switch (when the safety unlock is enabled)	4-12	LV battery warning light	4-21
Smart key* & REKES key	4-7	Cautions for using smart key.....	4-13	Air bag warning lamp	4-21
Function of each button	4-7	Using the emergency key.....	4-14	Brake warning light	4-22
Locking the door	4-7	Unfolding/folding the emergency key	4-14	Hill Descent Control (HDC) ON indicator/warning light.....	4-22
Unlocking the door (when the safety unlock is enabled)	4-8	Locking/unlocking the door using the emergency key	4-14	Electric power steering warning light.....	4-22
Unlocking the door (when the safety unlock is disabled)	4-9	Replacing the smart key battery	4-15	Electronic stability control system (ESC) ON indicator/warning light ..	4-23
Opening/closing the tailgate (A type).....	4-9	Instrument cluster.....	4-16	Electronic stability control system (ESC) OFF indicator	4-23
Activating/deactivating the panic mode (B type)	4-9	Trip info display	4-18	ABS (Anti-Lock Brake System) warning light	4-24
Additional functions	4-10	Speedometer.....	4-18	Electronic Brake-Force Distribution (EBD) warning light.....	4-24
Smart door auto lock (auto close)	4-10	Speedometer.....	4-18	Regenerative braking warning light.....	4-24
Activating the smart door auto lock function (Activating from the instrument cluster).....	4-10	POWER/CHARGE gauge.....	4-18	Base Brake System (BBS) warning light.....	4-25
Activating the smart door auto lock function (Activating with the smart key).....	4-10	High Voltage (HV) battery indicator.....	4-18	Global warning light	4-25
Locking/unlocking the door with the door handle switch.....	4-11	Distance To Empty (DTE)	4-19	Steering wheel heater indicator* ...	4-25
To lock with door handle switch	4-11	Regenerative braking level indicator.....	4-19	Immobilizer/smart key warning light.....	4-26
		Odometer	4-20	Electronic Parking Brake (EPB) warning light*	4-26
		Electronic shift lever indicator.....	4-20	Autonomous Emergency Braking System (AEBS) warning light.....	4-26
		Digital clock	4-20		
		Ambient temperature Indicator	4-20		
		Warning lights and indicators	4-21		

Autonomous Emergency Braking System (AEBS) OFF indicator	4-27
Turn signal/hazard warning lamp	4-27
Illumination ON indicator	4-27
Front fog lamp ON indicator*	4-28
Rear fog lamp ON indicator	4-28
ECO indicator	4-28
ECO+ indicator	4-29
SPORT indicator	4-29
SHB indicator*	4-29
AUTO HOLD indicator/warning light*	4-30
LKA (LDW) indicator / warning lamp 4-30	
High beam indicator	4-31
Vehicle READY indicator	4-31
Service required warning light	4-31
Power down warning light	4-32
Charging indicator	4-32
HV battery level warning light	4-32
HV battery fault warning light	4-33
Virtual Engine Sound System (VESS) warning light	4-33
Door ajar warning light	4-33
Motor room hood open warning light	4-34
Smart tailgate indicator	4-34

Master symbol	4-34
Indicator panel on instrument cluster	4-35
Main menu	4-35
Main menu list	4-36
Trip computer information	4-37
Mileage/average speed/driving time	4-37
Fuel economy	4-37
Power consumption	4-38
Charge Information	4-38
Power flow	4-39
TPMS status	4-39
Digital speedometer	4-39
Driving assist Menu	4-40
Driving assist	4-40
Driver attention alert	4-40
AV screen	4-40
TBT (Turn By Turn)	4-41
User settings	4-42
Message on the display of the instrument cluster	4-47
Instrument cluster illumination brightness	4-99
To adjust instrument cluster illumination brightness	4-99

SBW (shift by wire)	4-100
Transmission selector lever position	4-100
How to move shift lever to target gear position	4-101
Functions for each shift position	4-102
P (park) position	4-102
R (reverse) position	4-102
N (neutral) position	4-103
D (drive) position	4-103
Regenerative braking system	4-104
Regenerative braking control (paddle shifter)	4-104
Regenerative braking settings	4-105
Operation of EV	4-106
Drive mode	4-107
Drive mode switch	4-107
Default settings for each mode	4-107
Intelligent / Adaptive Cruise Control*	4-108
Intelligent cruise control switch	4-108
Cruise control switch	4-108
Intelligent Cruise Control Ready / Enabled Display	4-108
Set intelligent cruise (enabled)	4-108
Intelligent Cruise Control Ready	4-109

To enable intelligent cruise control at instrument cluster	4-109	To change lane	4-119	ABS (Anti-Lock Brake System)	4-129
To set intelligent cruise control (IACC)	4-109	Detecting vehicle ahead	4-120	ABS warning light	4-130
Increasing speed	4-110	Safety Speed Assist (SSA)	4-121	Electronic Brake-Force Distribution (EBD)	4-130
Decreasing speed	4-110	SSA status indicator	4-121	EBD warning light	4-130
Temporary acceleration (override)	4-110	Enabling SSA	4-121	Emergency Stop Signal (ESS)	4-131
Deactivating	4-111	SSA operating conditions	4-121	Activation and deactivation conditions	4-131
Disable conditions	4-111	SSA operation	4-122	Electronic stability control system (ESC)*	4-132
Other disable conditions	4-111	Speed Limit Warning (TSW)	4-125	ESC indicator/warning light	4-132
Resume	4-112	Images that show readiness and operation	4-125	ESC OFF indicator	4-132
To Deactivate	4-112	Speed Limit Warning (TSW) ready	4-125	Phenomenon that occurs when the ESC is activated	4-133
Steering wheel (steering force) control alert	4-113	To set Speed Limit Warning (TSW)	4-125	When it is necessary to deactivate the ESC function	4-133
To set safety distance to front vehicle	4-115	How to enable Speed Limit Warning (TSW) in instrument cluster	4-126	Hill Descent Control (HDC)	4-134
Forward situation awareness	4-116	To set speed	4-126	Activating/deactivating the HDC function	4-134
Starting at congested areas	4-116	To deactivate speed limit warning (TSW)	4-126	HDC indicator/warning light	4-135
Front detection sensor (Front radar + front camera)	4-116	Brake system	4-127	HDC activation conditions	4-135
Vehicle detection is difficult under the following circumstances:	4-117	Foot brake	4-128	HDC deactivation conditions	4-135
Not detected preceding pedestrian	4-118	Checking for foreign materials on the pedal operation area	4-128	HDC operation	4-135
Curved road	4-118	Checking and replacing the brake pads/discs	4-129	Electronic Parking Brake (EPB)	4-136
Uphill or downhill	4-119	If the brake is not working	4-129	Applying the EPB	4-136
				Releasing the EPB	4-136
				Releasing the EPB automatically	4-137

EPB warning light/brake warning light.....	4-137
EPB emergency mode	4-137
AUTO HOLD	4-139
Activating the AUTO HOLD function	4-139
Deactivating the AUTO HOLD function	4-139
Using the AUTO HOLD function..	4-139
AUTO HOLD indicator/warning light.....	4-140

Autonomous Emergency Braking (AEB)..... 4-141

AEB indicator/warning light.....	4-141
AEB OFF indicator	4-141
AEB indicator/warning light.....	4-142
AEB is activated	4-142
Setting the sensitivity of the forward collision warning	4-143
AEBS operation	4-143
Activation conditions	4-144
Deactivation conditions.....	4-144
The AEB cannot detect a vehicle properly:	4-145
The AEBS cannot detect a pedestrian.....	4-147

Rear and side warning system*..... 4-149

Display of rear and side warning system activation.....	4-149
Activating/deactivating the warning buzzer of the rear and side warning system.....	4-150
Warning level of the rear and side warning system.....	4-150
1st warning	4-150
2nd warning	4-150
When the rear and side warning system is abnormal.....	4-151
Blind Spot Warning (BSW) system.....	4-152
Activation conditions	4-152
Lane Change Warning (LCW) system.....	4-152
Operating conditions	4-152
RCTW System.....	4-153
Activating / deactivating RCTW system	4-153
Activation conditions	4-153
RCTA System	4-154
Activating / deactivating RCTA system	4-154
Operating conditions:	4-154

Cases where RCTA system not work.....	4-155
Cases where the RCTA system malfunctions	4-155
SEW System	4-156
Activating / deactivating SEW system	4-156
Operating conditions:	4-156

LDW (Lane Departure Warning) 4-157

To activate / deactivate lane departure warning (LDW).....	4-157
Activating/deactivating the LDW	4-157
LDW ON indicator.....	4-158
Activation conditions	4-158
Message on instrument cluster.....	4-159
Both lane lines are detected	4-159
Only one lane line is detected	4-159
Driving at low speed or both lane lines are not detected	4-159
Approaching a lane line without a turn signal	4-159
LDW cannot operate.....	4-160
System check in progress	4-160
System OFF.....	4-160
Cases that the system is not activated	4-160

Cases requiring the driver's attention.....	4-161
Lane Keeping Assistance (LKA)	4-163
To activate / deactivate lane keeping assistance (LKA)	4-163
To enable / disable LKA	4-164
LKA ON indicator	4-164
Operating conditions	4-164
Message on instrument cluster.....	4-165
Both lane lines are detected	4-165
Only one lane line is detected	4-165
Driving at low speed or both lane lines are not detected	4-166
Approaching a lane line without a turn signal	4-166
LKA cannot operate	4-166
System check in progress	4-166
System OFF	4-166
Cases that the system is not activated	4-167
Cases requiring the driver's attention.....	4-167
ELK (Emergency Lane Keeping)	4-169
RKA-ROADEDGE (Lane Keeping Assist-Roadedge).....	4-169

Activation / Deactivation.....	4-169
Operating conditions.....	4-169
Does not work when:	4-170
Driver Attention Required.....	4-171
RKA-ONCOMING(Lane Keeping Assist-Oncoming)	4-172
Activation / Deactivation.....	4-172
FVSA (Front Vehicle Start Alarm)*.....	4-173
How To Set	4-173
Operation	4-173
TSR (Traffic signal recognition)*.....	4-174
Setting.....	4-174
Parking assist system*	4-175
Front/rear obstacle detection system.....	4-175
Activating the obstacle detection system	4-176
Warning buzzer interval.....	4-178
Sensor and relevant system malfunction	4-178
If the system does not operate or malfunctions.....	4-179
Cautions regarding the front/rear obstacle detection system.....	4-179

Rear camera system.....	4-180
Double parking (2-row parking)	4-182
Vehicles With EPB.....	4-182

5. Emergency Measures in the Event of Emergency

OVM (Owner Vehicle Maintenance) tools	5-2
OVM tools	5-2
Location where the OVM tools are stored.....	5-2
When Low Voltage (12 V) Battery Discharged (Emergency Start-up).....	5-3
Starting the vehicle using the jump cable.....	5-3
When a tire is flat	5-5
Repairing a flat tire/inflating a tire using the service kit for tire repair.....	5-6
Components of the service kit for tire repair	5-6
Storage location of the service kit	5-6
Confirming whether it is possible to repair the flat tire with the service kit or not.....	5-6

Operating principle of the service kit	5-7	Driving on hill	5-20	Table for check and change intervals under normal conditions	6-4
Repairing a flat tire	5-7	Parking on hills	5-20	Table for check and change intervals under demanding conditions	6-7
Checking the tire pressure after repairing a flat tire	5-11	When you are ready to leave after parking on a hill	5-20	Checking Motor Room	6-8
Inflating a tire	5-12	Maintenance when towing trailer	5-20	Coolant	6-9
When you need to have your vehicle towed	5-14	When the vehicle has stopped due to a failure	5-21	Level Check & Replenishment	6-9
Towing a disabled vehicle	5-14	In the event of an accident	5-22	Brake and clutch fluid	6-10
Towing with tow truck	5-14	Tips when an accident or a malfunction occurs on the expressway	5-22	Specification and Replacement	6-10
For 2WD vehicles	5-14	In the event of a fire	5-23	Level Check and Replenishment	6-10
When a tow truck is unavailable (in case of emergency)	5-15	Placing an extinguisher in the vehicle	5-23	Washer fluid	6-11
Installing the towing hook	5-15	How to use the extinguisher	5-23	Low voltage battery (12V)	6-12
Using a towing rope	5-16	Checking and maintaining the extinguisher	5-24	Battery Maintenance	6-12
Trailer towing	5-17	In the event of a heavy snow	5-25	Specification	6-12
Trailer loading	5-17	6. Periodic Checking and Maintenance		Checking the wipers and replacing the blade	6-14
Maximum Load Limits	5-17	Maintenance Schedule	6-2	Replacing the blade of windshield wiper	6-14
If you want to pull a trailer	5-18	Oils capacity/specifications	6-3	Replacing the blade of rear window wiper	6-14
Weight of trailer	5-18	Periodic Checkup And Change Interval	6-4	Specifications of wiper blade	6-14
Weight of trailer tongue	5-18			Checking and replacing fuses and relays	6-16
Trailer brakes	5-19			Motor room fuse and relay box	6-16
Trailer lights	5-19				
Tires	5-19				
Safety chains	5-19				
Brake fluid	5-19				
Automatic transmission fluid	5-19				
Towing tips	5-19				

Interior fuse box	6-16	Checking the status of tire wear.....	6-29
Checking and replacing fuses	6-17	Rotating the tire positions	6-29
Checking and replacing the lamps.....	6-18	Snow tire.....	6-29
Specifications of lamps and checking	6-18	Tire chain	6-30
Specifications and quantity of lamps and bulbs.....	6-18	Cautions for checking the tires and wheels.....	6-30
Checking the lamps	6-19	Vehicle management during winter	6-32
Position of exterior lights and lamps	6-20	Starting the vehicle and driving the vehicle.....	6-32
Replacing exterior lamps.....	6-21	Managing the motor coolant	6-32
To replace license plate lamp	6-21	Managing washer fluid.....	6-32
Position of interior lamps	6-22	Installing a snow tire.....	6-32
Replacing the interior lamps	6-23	Managing the A/C.....	6-32
Replacing the front room lamp	6-23	Other maintenance	6-33
Replacing the center room lamp....	6-23	Cautions for parking during winter....	6-33
Replacing the sun visor/mirror lamp	6-24	Warnings for self-maintenance....	6-34
Replacing the glove box lamp.....	6-25		
Replacing the A/C filter	6-26		
Checking the tires and wheels	6-28		
Checking the tire pressure.....	6-28		
Prescribed tire inflation pressure.....	6-28		
Wheel alignment status and the balance between tires and wheels ...	6-28		

7. Index

Table of Pictures

Find the desired information using a picture easily even if you do not know the title of the desired information.

Front section

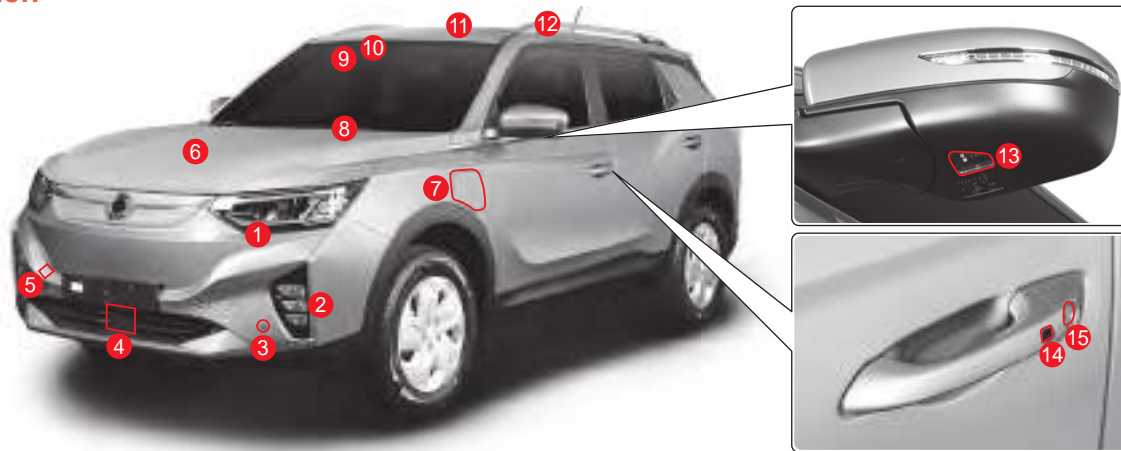

① Head light (head light).....	3-56	⑦ Electric vehicle charging door.....	3-34	⑩ Auto light/rain sensor.....	3-64/3-74
• Smart High Beam (SHB)	3-60	• Removal and installation of charging connector	3-38	⑪ Sunroof.....	3-20
• Daytime running light (DRL).....	3-59	• Charging status indicator.....	3-41	⑫ Roof rack	3-106
② Front fog light.....	3-56	• Slow and fast charging.....	3-42	⑬ Puddle lamp	3-62
③ Front obstacle detection sensor.....	4-175	• Portable charging.....	3-46	• Auto approach lamp	3-62
④ Front radar	4-116	⑧ Windshield wiper	3-73	• Welcome light	3-62
• Intelligent cruise control (iACC).....	4-108	⑨ Front camera module (FCM).....	4-116	⑭ Door outside handle switch.....	4-11
⑤ Front towing hook	5-15	• Autonomous Emergency Braking (AEB)	4-141	⑮ Door handle.....	4-14
⑥ Motor room hood.....	3-32	• Lane Departure Warning (LDW)	4-157	• Using emergency key.....	4-14
		• Lane Keeping Assistance (LKA)	4-163		
		• Emergency Lane Keeping (ELK)	4-169		

Rear section

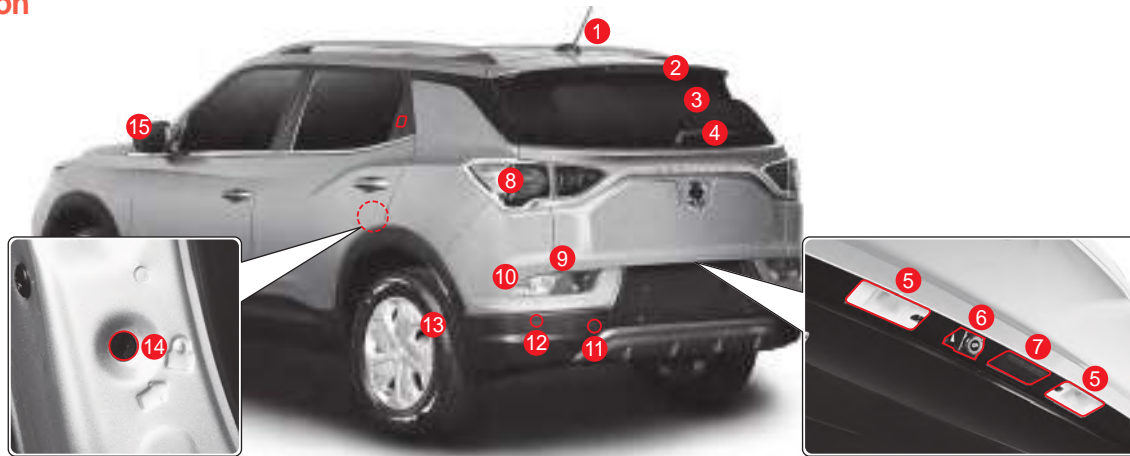

- | | | | | | | | | |
|---|--------------------------------------|------------------|----|--------------------------------------|------------------|----|---|------|
| 1 | Antenna (GPS, radio, DAB, GSM) | 3-92 | 7 | Tailgate open button | 3-24 | 13 | Tire and wheel..... | 6-28 |
| 2 | High mounted stop lamp ... | 3-55, 6-18, 6-20 | 8 | Rear lamp | 3-55, 6-18, 6-20 | | • In the event of flat tire | 5-5 |
| 3 | Rear window heater | 3-84 | 9 | Backup lamp..... | 3-55, 6-18, 6-20 | | • Tire pressure monitoring system (TPMS)..... | 2-29 |
| 4 | Rear window wiper | 3-74 | 10 | Turn signal lamp | 3-55, 6-18, 6-20 | 14 | Child safety door lock / unlock | 3-4 |
| 5 | License plate lamp | 3-55, 6-18, 6-20 | 11 | Rear towing hook..... | 5-15 | 15 | External mirror heater | 3-84 |
| 6 | Rear camera..... | 4-180 | 12 | Rear obstacle detection sensor | 4-175 | | | |

Driver seat door section

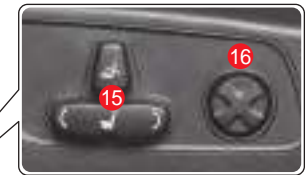

- | | | | | | |
|--|------|--|-------------|---|-------|
| 1 Driver door open lever | 3-2 | 7 Instrument cluster illumination
brightness switch | 4-99 | 11 BSD system switch | 4-149 |
| 2 Door lock/unlock button | 3-2 | 8 Lane departure warning (LDW) switch/
Lane keeping assist (LKA) switch
..... | 4-157/4-163 | 12 Tailgate button..... | 3-24 |
| 3 Window button | 3-17 | 9 Hill descent control (HDC) switch..... | 4-134 | 13 AC inverter operation switch | 3-94 |
| • Rear window lock button..... | 3-19 | 10 Electronic stability control (ESC)
switch | 4-132 | 14 Head light angle dial..... | 3-58 |
| 4 Outside mirror angle control switch | 3-75 | | | 15 Driver seat control lever/button..... | 3-7 |
| 5 Motor room hood opening lever..... | 3-32 | | | 16 Driver's lumbar support button..... | 3-9 |
| 6 Interior fuse box..... | 6-16 | | | | |

Driver steering wheel section

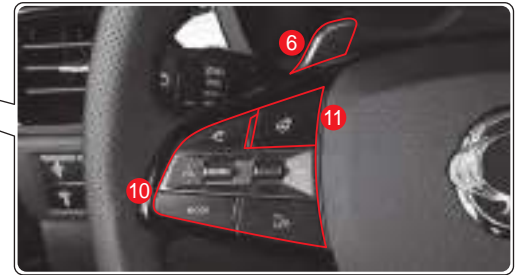
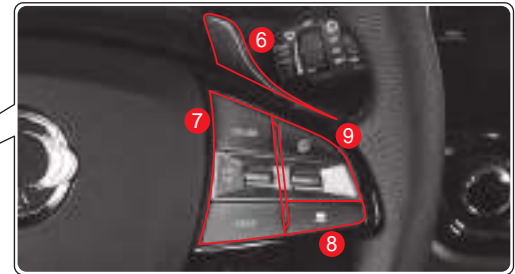

- | | | |
|--|--|--|
| 1 Foot brake..... 4-128 | 5 Driver air bag 2-22 | 9 Instrument cluster menu button and control button 4-35 |
| • Emergency stop signal (ESS) 4-131 | 6 Regenerative braking paddle shift 4-104 | 10 Audio system control button 3-91 |
| 2 Steering wheel telescoping/tilt control lever 3-88 | 7 Instrument cluster menu and control buttons 4-35 | 11 Steering wheel heater switch 3-88 |
| 3 Light switch 3-56 | 8 Button to set safety distance to front vehicle 4-115 | |
| 4 Instrument cluster 4-16 | | |

Interior front view

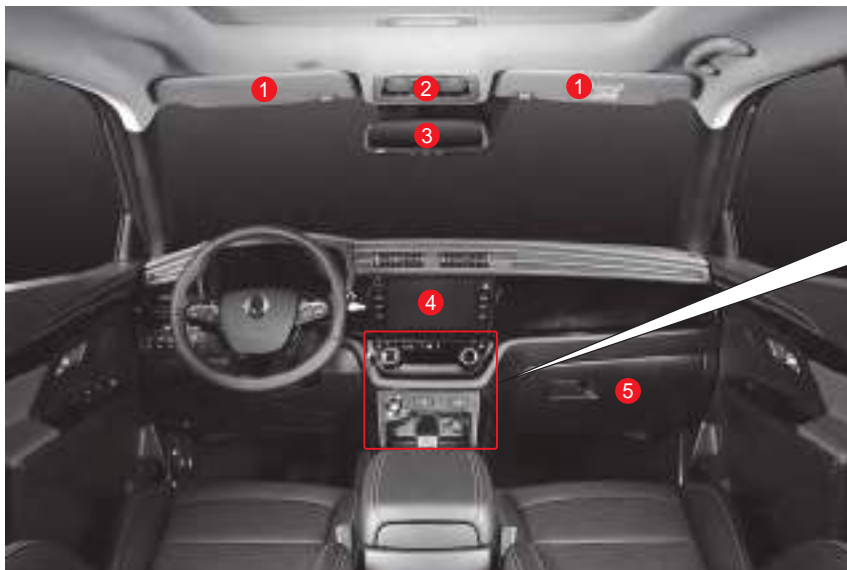

- | | | | | | |
|---|------|---|------|---|-------|
| 1 Sun visor..... | 3-96 | 4 Infotainment system | 3-89 | 9 START/STOP switch | 4-2 |
| 2 Overhead console assembly..... | 3-66 | • Smart audio..... | 3-89 | 10 Front seat warmer and ventilation
button | 3-13 |
| • Sunroof control switch | 3-21 | • AV/navigation | 3-90 | 11 USB port | 3-91 |
| • Front room lamp..... | 3-66 | 5 Glove box..... | 3-99 | 12 Power socket (front side of center
console)..... | 3-93 |
| • e-call | 3-68 | 6 Hazard warning lamp switch | 3-57 | 13 Wireless phone charger system | 3-101 |
| 3 Inside rear view mirror | 3-76 | 7 Glass heater switch..... | 3-84 | | |
| | | 8 Heater and A/C controller | 3-81 | | |

Central console section

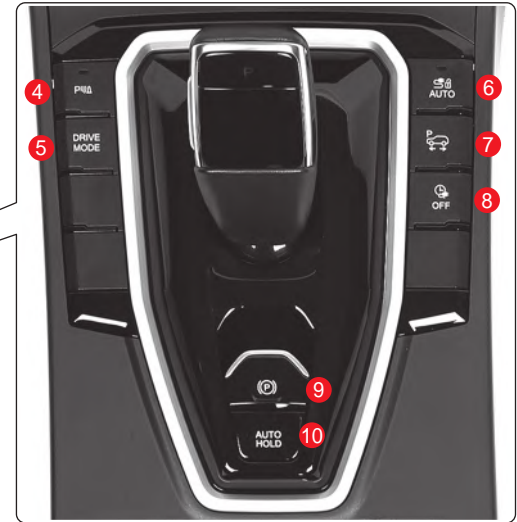
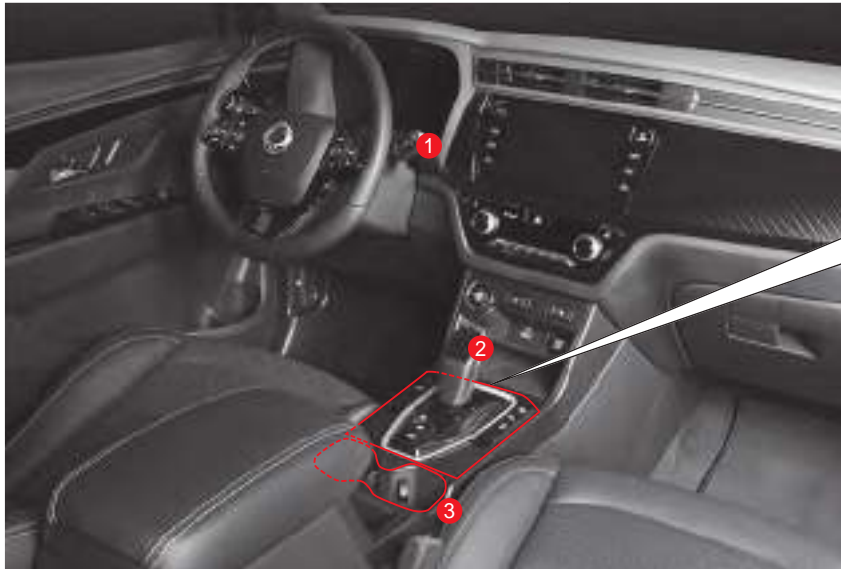

- | | | | |
|---------------------------------------|-------|--|-------|
| 1 Wiper and washer lever | 3-73 | 5 Driving mode switch | 4-107 |
| 2 Electronic shift lever | 4-100 | 6 Auto charging cable lock button..... | 3-40 |
| • How to move selector lever to | | 7 P (park) release switch | 4-182 |
| target gear position | 4-101 | 8 Reservation charging button | 3-54 |
| • Regenerative braking | 4-104 | 9 Electronic parking brake (EPB) | |
| 3 Front seat cup holder..... | 3-98 | switch | 4-136 |
| 4 Front parking assist warning ON/OFF | | 10 AUTO HOLD switch | 4-139 |
| switch | 4-175 | | |

Rear seats

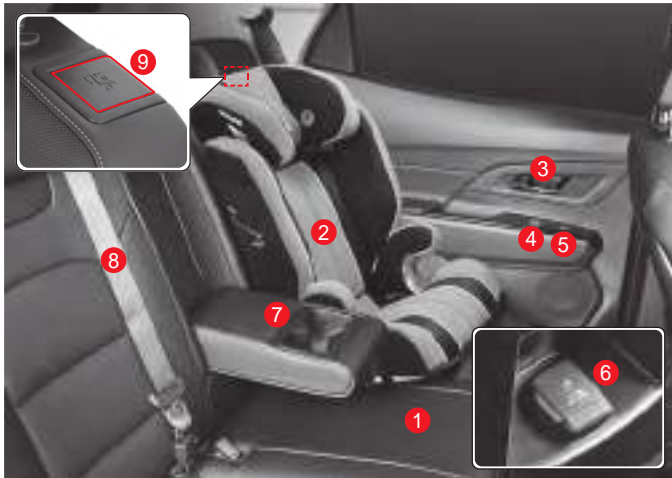

1	Rear seat	3-11
2	Baby car seat	2-11
3	Rear seat door open lever	3-2
4	Rear seat window button	3-18
5	Rear seat warmer button	3-15
6	AC inverter (rear side of the central console)	3-94
7	Rear cup holder and armrest	3-98
8	Rear seat belt	2-6
9	Rear seatback release lever	3-11

Luggage compartment

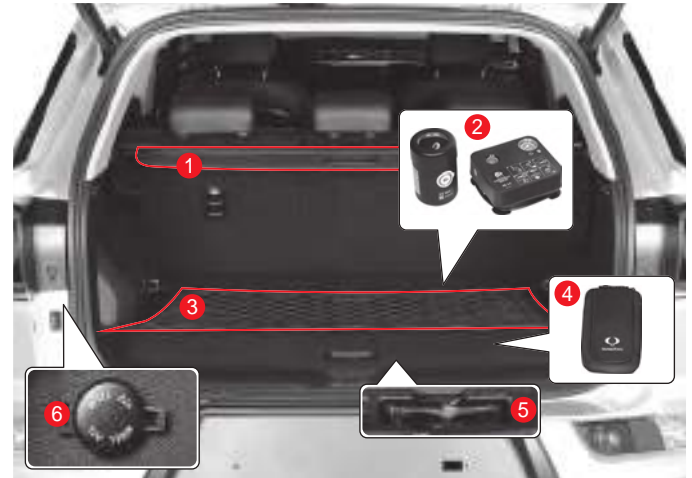

1	Luggage upper cover	3-103
2	Service kit for tire repair	5-6
3	Luggage net	3-105
4	Portable charger	3-46
5	OVM tools	5-2
6	Power socket (left side of luggage compartment)	3-93

Motor room

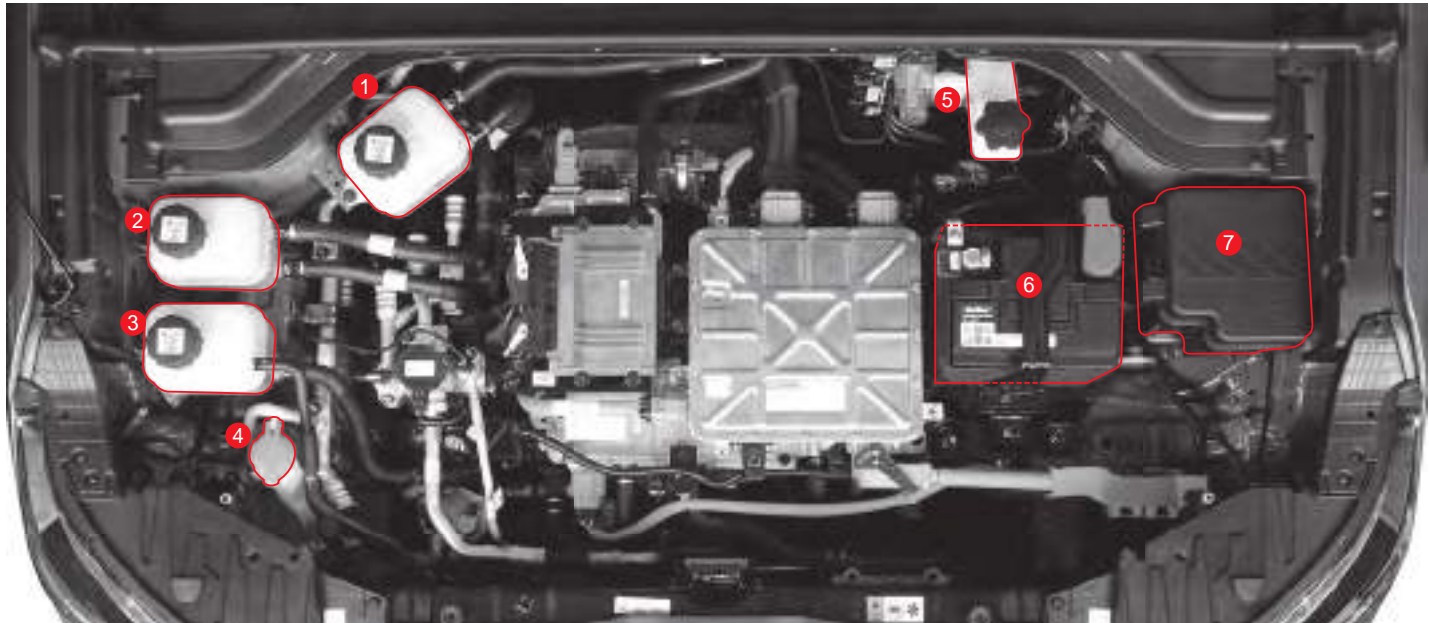

- | | | | | | | | | |
|---|--|-----|---|--|------|---|-------------------------------------|------|
| 1 | Heater cabin coolant auxiliary tank..... | 6-9 | 4 | Washer fluid filler | 6-11 | 7 | Motor room fuse and relay box..... | 6-16 |
| 2 | High-voltage battery coolant auxiliary tank..... | 6-9 | | • Checking and adding washer fluid ... | 6-11 | | • Checking and replacing fuse | 6-17 |
| 3 | Drive motor coolant auxiliary tank | 6-9 | 5 | Brake fluid reservoir | 6-10 | | | |
| | | | | • Checking brake fluid | 6-10 | | | |
| | | | 6 | Low-voltage (12 V) battery..... | 6-12 | | | |
| | | | | • Checking and replacing low-voltage (12 V) battery..... | 6-12 | | | |

Warning lights and indicators

Image	Meaning/Relevant page
	Seat belt warning lamp 2-2, 4-21
	Air bag warning lamp 2-20, 4-21
	Global warning light..... 4-25
	Immobilizer/Smart key warning light 2-35, 4-26
	Charge warning light 4-21
	SSPS warning lamp 4-22
BRAKE (!) (P)	Brake warning light 4-22, 4-127, 4-130
(ABS)	ABS (Anti-Lock Brake System) warning light 4-24, 4-127, 4-130





Image	Meaning/Relevant page
(ABS) BRAKE (!) (P)	Electronic brake force distribution (EBD) warning light 4-24, 4-127, 4-130
EPB	Electronic parking brake (EPB) warning light 4-26, 4-136
AUTO HOLD	AUTO HOLD indicator/ warning light 4-30, 4-139
	Steering wheel heater indicator 4-25
	Electronic stability control system (ESC) ON indicator/ warning light 4-23, 4-132
	ESC OFF indicator 4-23, 4-132
	Autonomous Emergency Braking (AEB) warning light 4-26, 4-141
AEBS OFF	AEBS OFF indicator 4-27, 4-141









Image	Meaning/Relevant page
	HDC ON indicator/ warning light 4-22, 4-135
	LKAS (LDWS) indicator / warning lamp 4-30, 4-158
	Illumination ON indicator ... 4-27
	Front fog light ON indicator 4-28
	SHB indicator..... 4-29
	High beam indicator 4-31
	Turn signal/hazard warning lamp 4-27
	Rear fog lamp ON indicator 4-28

Image	Meaning/Relevant page
	Motor room open warning lamp 3-32, 4-34
	Door ajar warning lamp..... 4-33
	Master symbol 4-34
	Smart tailgate..... 3-32, 4-34
SPORT	SPORT mode indicator 4-29, 4-107
ECO	ECO mode indicator 4-28, 4-107
ECO+	ECO+ mode indicator 4-29, 4-107
	Ready lamp 4-31

Image	Meaning/Relevant page
	Virtual engine sound system (VESS) OFF indicator..... 4-33
	Check EV battery warning lamp..... 4-33
	Low EV battery level warning lamp 4-32
	Charging status indicator... 4-32
	Power down warning lamp..... 4-32
	High-voltage system warning lamp..... 4-31
	Regenerative braking warning lamp..... 4-24, 4-104
	BRAKE BBS warning lamp 4-25

<https://www.automotive-manuals.net/>

1. Vehicle Information and Safety Precautions

You can check helpful information for driving and managing the vehicle safely and conveniently.

Information regarding the vehicle identification, specifications, check points before driving the vehicle, safety precautions while driving, and vehicle maintenance methods is provided.

Information regarding the installation of ADR and provision of information

Installation of ADR (Accident Data Recorder) and provision of information

This vehicle has an ADR (Accident Data Recorder).

The ADR (Accident Data Recorder) is a device that can record and check the driving information of the vehicle (vehicle speed and operation status of brake pedal and acceleration pedal, etc.) for a certain period of time before and after an accident, such as a car crash.

The ADR (Accident Data Recorder) helps to better understand an accident situation.

Precautions for potentially hazardous seat belt related goods



Warning

When potentially hazardous seat belt related goods are used, the safety of passengers will be seriously endangered. Never use these goods.

Do not use the clip to disable the seat belt alarm



When this clip is inserted into the seat belt buckle, the seat belt is recognized as fastened, so the seat belt warning lamp and alarm are not activated.

This leads to no fastening of the seat belt, and it is very dangerous when an accident occurs.

Do not use the seat belt stopper



When it is installed on the seat belt, it hinders the normal automatic locking function of the retractor and lowers the performance of the seat belt.

Do not use playroom mat



When it is installed in the rear seat, it will lead to not fastening seat belts and car seats, and it is very dangerous when an accident occurs.

Precautions for the reduction of non-crash incidents



Warning

A part of your body may get stuck or hit and get seriously injured when opening and closing the doors. Caution should be taken.



- When you open and close the doors, a part of your body such as your finger or head may get stuck or hit and get seriously injured. Open and close the doors after ensuring that no part of your body is stuck or hit.



- When you open or close the trunk (tail gate), a part of your body such as your finger or head may get stuck or hit and get injured. Open or close the trunk after ensuring safety.
- The trunk (tail gate) is raised or lowered automatically at below or over a certain level. Always take caution to avoid your face or head from getting hit or your hand from getting stuck.



- Close the windows after checking that other passengers' hands or heads are away from the windows. This is especially important for children, who may get a serious injury, such as suffocation if their head gets stuck.
- When you pull the switch continuously to raise the window at a position where something is pinched first without operating the one touch auto close function, the anti-pinch function will not operate.
- Especially when a part of a child's body is on the window, a certain amount of force (resistance) is not applied to the window, so the anti-pinch function may not operate. Make sure to check before closing the windows.

Cautions for the protection of the environment

KG Mobility Corporation environment-related policies aim at comprehensive protection of the environment. This is also a way to save natural resources that become the basis of human survival on earth, and meet and harmonize the demands of nature and mankind.

You can contribute to the protection of the environment by operating our vehicle in an eco-friendly way.

High-voltage battery consumption, decelerator control, brake and tire wear are affected by driving conditions and driving style.

Observe the following content and participate in the protection of the environment.

Driving conditions

- Avoid short-distance driving as high-voltage battery consumption is relatively high.
- Always check if the tire inflation pressure is appropriate.
- Unload unnecessary goods from the luggage compartment.
- Always check high-voltage battery consumption.
- Have your vehicle checked periodically.

Driving habits

- Do not depress the accelerator pedal when starting the vehicle.
- Drive off in the vehicle slowly.
- Keep a safe distance with the vehicle ahead and drive carefully.
- Avoid frequent acceleration or deceleration.
- Avoid sudden acceleration, deceleration, or stops.
- Turn off the motor when you stop the vehicle for a long time.

Recycling

- Information about eco-friendly product development and vehicle recycling can be found on the KG Mobility Corporation website www.kg-mobility.com/en

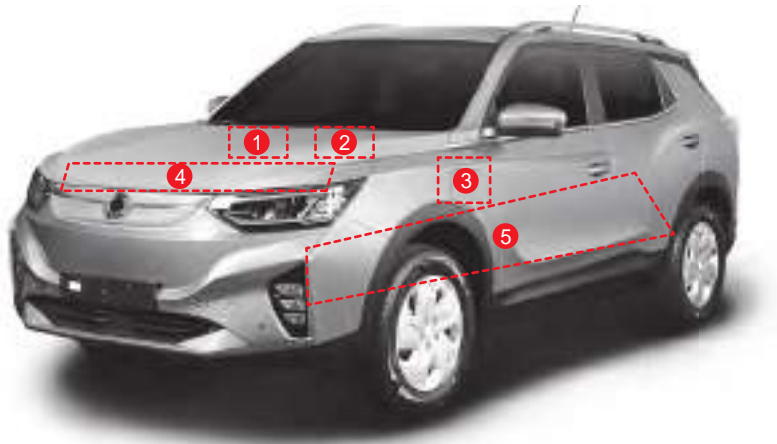

Electric vehicle means a vehicle that drives an drive motor using power from a high voltage battery and operates in a similar manner to the vehicle with an internal combustion engine. The basic difference is that it uses electrical energy instead of fossil fuels, and it is an eco-friendly vehicle without emissions.

- ① Drive motor
- ② Low voltage (12V) battery
- ③ Vehicle charging inlet
- ④ Orange high voltage electric wiring
- ⑤ High voltage battery

Battery

There are two types of batteries:

- 400 V high voltage battery
- 12 V low voltage battery

400 V drive battery

It stores the energy required to drive the vehicle and, due to the nature of the drive battery, it discharges when used, and must be charged regularly.

You don't have to wait by the vehicle until the charging is complete.

To fully charge the drive battery, it takes approximately 11 hours with a slow charger and approximately 30 to 1 hour with a fast charger.

The single-charge mileage depends on the state of charge of the drive battery, but is also affected by driver's driving style.

High voltage (drive) battery

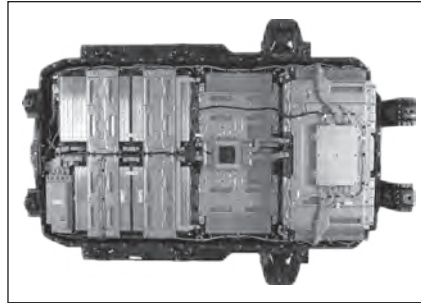

- The remaining level of the high voltage (drive) battery may gradually decrease even if the vehicle is not driven.
- Storing the vehicle in a high or low ambient temperature may reduce the capacity of the high voltage (drive) battery.
- The driving range may be shorter depending on driving conditions (e.g. driving on hills and rapid acceleration).
- The driving range may be shorter when cooling or heating the interior of the vehicle while using power from the high voltage (drive) battery. Always keep the vehicle's interior temperature at an appropriate level.
- Depending on the age of the vehicle, natural deterioration of the high voltage (drive) battery may occur, reducing the driving range.

- If the charging capacity and driving range continue to decrease, have the system checked and serviced by a KG Mobility Authorized Service Center.
- If the vehicle is not in service for a long period of time, charge the high voltage (drive) battery about once every three months to prevent it from being discharged.
- To keep the high voltage (drive) battery in optimum condition, it is recommended to charge it to 100% with a slow charge.

Caution

- **Be sure to use the specified charger when charging the high voltage (drive) battery. Otherwise, it may lead to electric vehicle failure and adversely affect battery performance (durability).**
- **Never let the high voltage (drive) battery charging gauge go down to the low (L) level. It may damage the high voltage (drive) battery or reduce its capacity.**
- **In the event of a collision that can cause a major impact on the vehicle, have the battery connection checked and serviced at KG Mobility Dealer or KG Mobility Authorized Service Operation.**

12 V battery

The auxiliary battery fitted to the vehicle is a 12 V battery which is similar in form to that of a diesel or gasoline vehicle. This battery provides the energy necessary for vehicle electrical devices such as lamps, wipers, audio systems, etc. to operate.

⚠ Caution

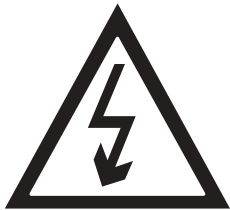

- An indication that the vehicle's electrical elements may pose a risk to the safety of the occupants.

400 volts electrical circuit

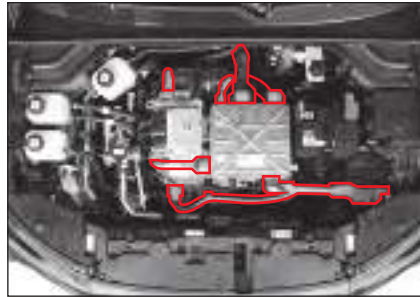

The orange wiring has ⚠ marking to help identify.

⚠ Warning

- The vehicle's driving system uses about 400 volts of electricity. This system may be hot during operation and even after the ignition is turned off. Please read thoroughly the warnings on the label on the inside of the vehicle.
- Any manipulation and deformation of the 400 volt electrical system (components, wires, connectors, drive batteries) is strictly prohibited as this may pose a safety hazard. Consult KG Mobility Dealer or KG Mobility Authorized Service Operation.

Driving

To drive an electric vehicle, you need to get used to not using your left foot when braking the brakes.

When the driver releases his/her foot from the accelerator pedal, the electric motor generates an electric current to charge the driving battery during deceleration.

The electric motor has a regenerative braking function that allows the engine brake to operate more strongly than diesel or gasoline vehicles, which can result in a feeling of greater driving resistance.

Features

After a full charge of the high voltage battery, the engine brake is temporarily weakened during the first few kilometers of driving. Please be aware of this when driving.

⚠ Warning

- Under no circumstances can the engine brake replace braking with the brake pedal.

For inclement weather or watery roads:



If the water depth rises to the lower edge of the wheel, do not drive on that road.



Warning

Driving interference

- **The driver's floor mat must use the genuine mat provided at the time of purchase of the vehicle and regularly ensure that the mat is secured to the floor. In addition, do not use multiple mats overlapped.**
- **It may interfere with the pedal operation or cause a serious accident due to the pedal being caught in the mat.**

Noise

Engine noise rarely occurs in the electric vehicles. Please pay attention to pedestrian safety when driving at low speed to prevent accidents caused by pedestrians not being aware of vehicle approach.

Unfamiliar sounds may be heard, such as air sound, tire sound, etc.

And there is a charging noise (e.g., air conditioning for cooling the drive battery). Please be aware of this.



Warning

- **Due to the low noise of the electric vehicle, it is essential to place the shift lever to the P position, apply the parking brake.**

Emergency measures in case of emergency

To change P (park) position

In an emergency, change the P (park) position as follows:

- 1 Depress and hold the brake pedal with the vehicle in full stop.
- 2 Press the P(park) button.

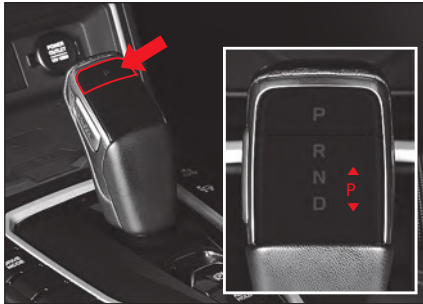

Warning

- Do not move to the P (park) position unless the vehicle is stationary.
- Do not attempt to place the shift lever in the P position instead of applying the parking brake.

Notice

- If the ignition switch is turned off in a position other than P (park), the shift lever automatically moves to the P (park) position.

Double parking (2-row parking)

Since double parking (2-row parking) is required due to insufficient parking space, operate as follows.

- 1 With the START/STOP switch in the ON status or while the vehicle is running, release the Electronic Parking Brake (EPB).

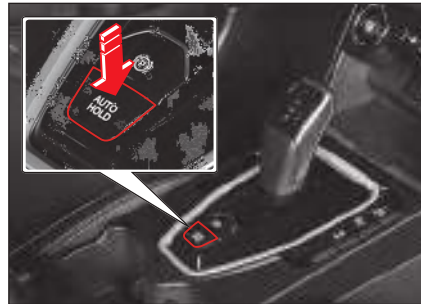

Notice

- If the AUTO HOLD function is activated, the EPB is activated automatically. Be sure to deactivate the function by pressing the AUTO HOLD switch before carrying out the process.

- 2 Press the P (park) release switch while depressing the brake pedal within 30 seconds of turning the ignition switch OFF. The “N” position on the SBWS lever light up.



Warning

- Be sure to carry out double parking (2-row parking) on completely flat ground and take a separate measure such as placing a chock on the wheels. Failure to do so may cause the vehicle to move, that is very dangerous.
- When using an automatic car washer, etc. in double parking mode, i.e. with the gear selector lever in the N (neutral) position, never press the P (park) button. If you drive the vehicle into a car wash with the gear selector lever in the P (parking) position, problems may occur in your vehicle, automatic car washer and etc.

Lift and mounting points

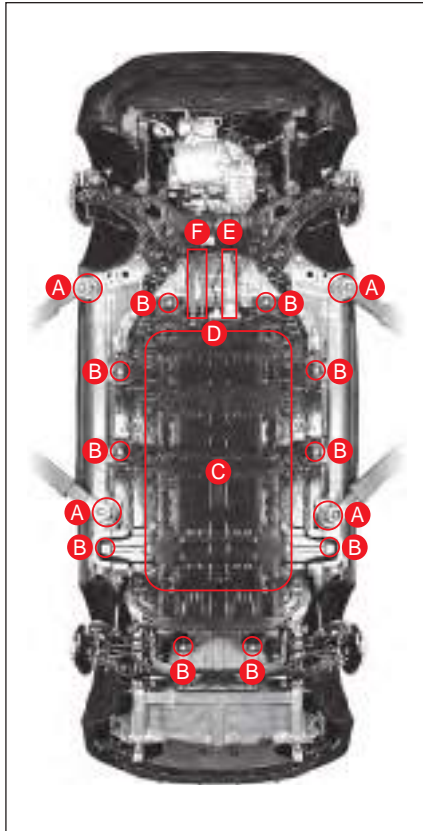

- A** Vehicle lift points
- B** High voltage battery mounting points
- C** Center of gravity of high voltage battery
- D** High voltage battery lift points
- E** High voltage cable
- F** Coolant in/out

Stationary vehicle (OFF)

You can turn off the vehicle with the SBW (shift by wire) in the P (park) position and the brake pedal depressed.

To turn ignition off

- 1 Allow the vehicle to come to a full stop and depress and hold the brake pedal.
- 2 Place the SBW (shift by wire) in the P (park) position.
- 3 Activate the EPB.
- 4 Press the START switch to turn off the ignition.
- 5 When the ignition is turned off, release your foot from the brake pedal.

Before exiting the vehicle, make sure that the ignition is turned off and that there are no other abnormalities, and get off with the smart key.

To turn ignition off while driving (in case of emergency)

If you need to turn off the ignition in an emergency situation such as an accident or vehicle damage while driving, press and hold the START switch for at least 3 seconds or press 3 times within 1.5 seconds.

The ignition will be switched off and the START switch enter the ACC state.

Warning

- **Never turn off the ignition while driving unless it is an emergency, such as an accident or damage to the vehicle. It can be very dangerous as the steering wheel becomes difficult to maneuver and the braking performance of the brake decreases.**

Safety precautions for electric vehicle

Safety plug



Caution

- **Never touch a safety plug located in the center of the rear seat. The safety plug is a device to cut off the high voltage of the battery in the KG Mobility dealer or KG Mobility Authorized Service Center when repairing the vehicle. If handled carelessly, it can cause electric shock.**

Safety interlock connector

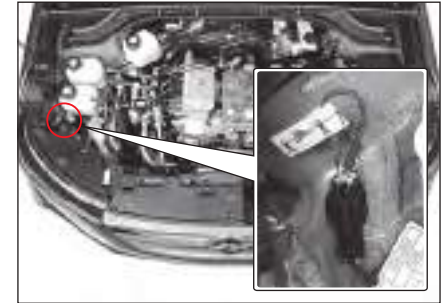

Cut the safety interlock connector to cut off the battery high voltage in an emergency.

To cutoff power from high voltage battery

Safety plug

The safety plug is installed at the bottom of the rear seat to shut off high voltage battery power. Remove the safety plug only in situations such as maintenance or emergencies.

- 1 Remove the rear seat center floor mat (1).



Warning

- The safety plug is a device for cutting off power the high voltage battery. Be sure to wear insulation suit and insulated gloves when removing the safety plug, as there may be risks such as electric shock.

- 2 Unscrew the safety plug fixing cover (2) bolts (6 mm, 4 EA) and remove the fixing cover.

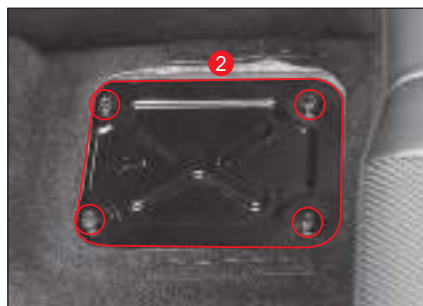

- 3 With the safety plug fastener (3) pressed down, pull the safety plug handle in the direction of the arrow (4).

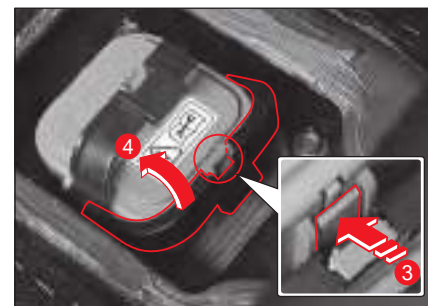

Notice

- Pulling the safety plug handle to the center part separates the safety plug connector part.

Step 1. Lock state



Step 2. Pull out the CPA button



Step 3. Pull up CPA button



Step 4. Rotate Here



4 Lift the safety plug in the direction of the arrow to disconnect it from the vehicle.

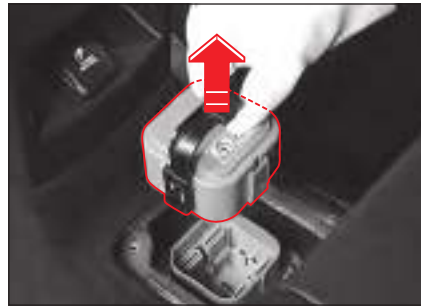

Safety interlock connector

The motor room has a safety interlock connector for cutting off power from the high voltage battery in an emergency. Follow the appropriate procedure to cut the safety interlock connector wiring.

- 1 The safety interlock connector is located on the left side when the motor room is opened. Cut the corresponding wiring.

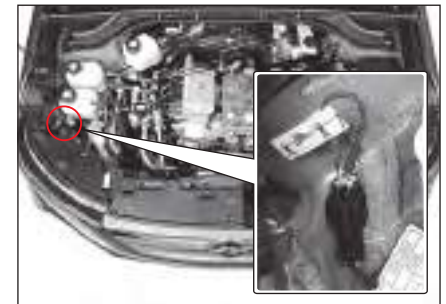

Warning

- Never cut the wiring unless it is an emergency. This will disconnect power from the high voltage battery, preventing the vehicle from starting.

To cutoff power from low voltage (12 V) battery

- 1 The low voltage (12 V) battery is on the right side when the motor room is opened.
- 2 Unscrew the mounting bolt (10 mm) for the low battery (12 V) battery (-) terminal to remove the (-) terminal.

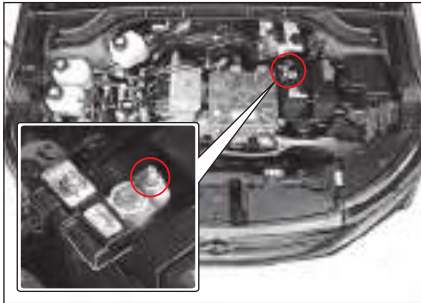

Specifications	MF / 12V – 50 Ah
Capacity	50 Ah

Warning

- Before removing the low voltage battery, stop at a safe place to protect the low voltage system and prevent unnecessary illumination of the warning lamp and remove the battery with the ignition completely turned off (ACC OFF).

OVM tools

The OVM tools are apparatuses or tools stored in the vehicle in preparation for a failure or an emergency situation that can occur while driving the vehicle.



- 1 Sealant (Emergency sealing compound in case of a flat tire)
- 2 Compressor (managing the tire pressure and injecting sealant in case of a flat tire)
- 3 Spanner
- 4 Screwdriver (+ and -)
- 5 Vehicle towing hook
- 6 Tool roll pouch

Location where the OVM tools are stored

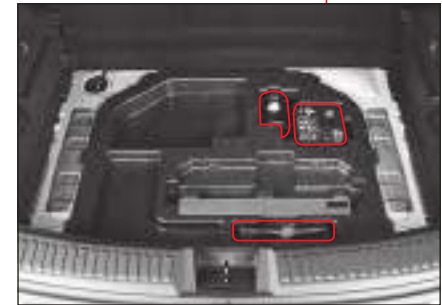

The OVM tools are stored in the storage box at the rear left side of the luggage compartment.

Take out and use the OVM tools any time when necessary.

When towing truck unavailable (in an emergency)

If a towing truck is unavailable and a vehicle is to be towed, you can tow the towed vehicle by attaching the towing hooks to the towing vehicle and the towed vehicle and connecting the two vehicles with a rope (sold separately).

To fit towing hook

- 1 Take the vehicle towing hook out of the on-vehicle material (OVM) at the bottom of the cargo compartment board.
- 2 **Front bumper**
Lift the lower part (1) of the hole cover in the front bumper of the vehicle to be towed in the direction of the arrow to remove the cover.
Rear bumper
Press the lower part of the hole cover (1) on the rear bumper of the vehicle to be towed to remove the cover.
- 3 Fasten the towing hook firmly by inserting it into each hole.

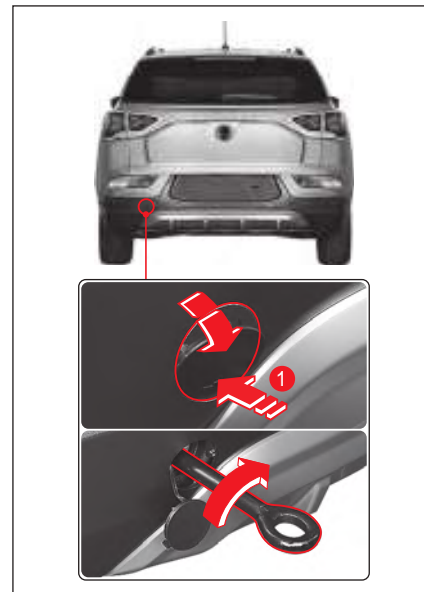
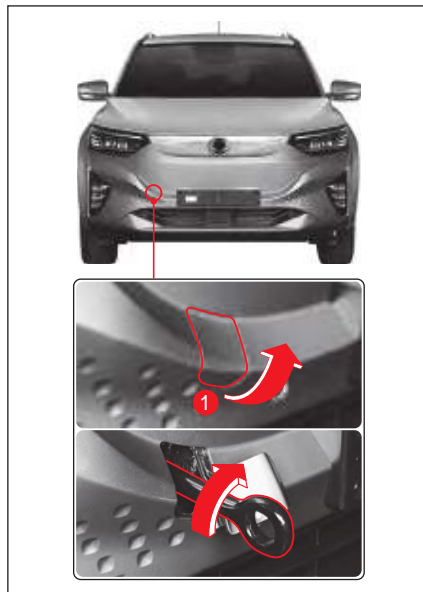

Cautions

Warning

Please observe the following:



Warning

In the event of an impact on underside of vehicle or such an accident

Any impact on the underside of the vehicle or such an accident (e.g. contact with signs, sidewalks, or street furniture) may result in electrical circuit or battery damage. Have your vehicle checked at KG Mobility Dealer or KG Mobility Authorized Service Operation.

Never touch orange wiring and 400 volts electrical components exposed to the inside or outside of the vehicle.

If the battery is critically damaged, a temporary leak may occur.

- Never touch liquids flowing out of the battery.
- If battery fluid is on your body, flush it with plenty of water and seek medical attention as soon as possible.

When there is, even if minor, an impact or accident on the charging outlet cap or valve, visit KG Mobility Dealer or KG Mobility Authorized Service Operation immediately for service.



Warning

In case of fire

In the event of a fire, exit the vehicle immediately and call for emergency assistance, explaining well that the situation occurred in an electric vehicle.

The fire extinguishers that can be used in electrical system fires are ABC type (for general fires / oil fires / electric fires), BC type (for oil and electric fires), and C type (for electric fires). Do not use water or other extinguishing substances.

In the event of damage to the electrical circuit, consult KG Mobility Dealer or KG Mobility Authorized Service Operation.



Warning

Towing

Refer to Chapter 5 "Towing: Towing Point - Towing Type" and "Towing: Method".



Warning



Vehicle washing

Never wash electric motor, charging inlets or drive battery. There is a risk of damage to the vehicle's electrical circuits.



Never wash your vehicle while charging it. There is a risk of personal injury or damage to the electrical equipment.

Certification



1. TIRE PRESSURE MONITORING SYSTEM

CE	<p>Hereby, KG Mobility, declares that the in-vehicle mounted radio systems are in compliance with the essential requirements and other relevant provisions of Directive 1999/5/EC</p>	EU
FCC	<p>Model: TSSSG4G5 and TSSRE4Db FCC ID: OYGTSSRE4DB ORD. No: 14778/DFRS19614/F-50 This device complies with Part 15 of the Federal Communications Commission (FCC) rules. Operation is subject to the following two conditions:</p> <ol style="list-style-type: none"> (1) this device may not cause harmful interference, and (2) this device must accept any interference received, including interference that may cause undesired operation. <div style="border: 1px solid black; background-color: #f4a460; padding: 5px; text-align: center; margin: 10px 0;">  Warning </div> <ul style="list-style-type: none"> • Changes or modifications not expressly approved by the party responsible for compliance could void the user's authority to operate the equipment. 	AMERICA
CU TR	<p>LOGO</p>  <p>Certificate in the user manual due to product size Tire Pressure Monitoring System Model: TSSRE4Db</p> <p>The device passed all the conformity assesment procedures to CU TR.</p>  EAC mark in the user manual due to product size.	CIS

2. FOB/FOLDING

FCC	<p>FCC ID: DEO-MT-FLIP01</p> <p>This device complies with Part 15 of the Federal Communications Commission (FCC) rules.</p> <p>Operation is subject to the following two conditions:</p> <ol style="list-style-type: none"> (1) this device may not cause harmful interference, and (2) this device must accept any interference received, including interference that may cause undesired operation. <div style="border: 1px solid black; background-color: #f9cb9c; padding: 5px; margin-top: 10px;"> <p style="text-align: center;"> Warning</p> <ul style="list-style-type: none"> Changes or modifications not expressly approved by the party responsible for compliance could void the user's authority to operate the equipment. </div>	AMERICA
TR	<p>LOGO</p>  <p>Certificate in the user manual due to product size</p>	CIS

3. Compressor, Jack

CE	<p>LOGO</p>  <ol style="list-style-type: none"> (1) Description Model: CE certified parts (2) Representative: KG Mobility European Parts Center B.V. (3) Address: IABC 5253&5254, 4814RD Breda, The Netherlands 	EU
UKCA	<p>LOGO</p>  <ol style="list-style-type: none"> (1) Description Model: UKCA certified parts (2) Importer: KG Mobility UK Ltd (3) Address: G Offices, Parsonage Road, Stratton St. Margaret, Swindon, Wiltshire SN3 4RN 	UK

1

Vehicle identification

The identification numbers including the vehicle are the unique information of the vehicle. If you know this information, it is very convenient for making inquiries about the vehicle or placing an order for a component or accessory.

Manufacturer's plate

The manufacturer's plate includes information including the vehicle identification number, tire inflation pressure, vehicle weight, and color necessary for maintaining the vehicle properly.

TYPE A

KG MOBILITY			
1		kg	kg
2		kg	kg
BODY PAINT COLOR			
DATE OF MANUFACTURE			
<small>KG MOBILITY: European Parts Center B.V. Contact address: BMC 520 & 526, 40-5400 Breda, The Netherlands</small>			

TYPE B

KG MOBILITY		
VEHICLE WEIGHT		KG
TOTAL WEIGHT (VEHICLE WEIGHT + TIRE WEIGHT)		KG
TIRE WEIGHT (PER SIDE)		KG
FRONT AXLE WEIGHT		KG
REAR AXLE WEIGHT		KG
DATE OF MANUFACTURE		
BODY PAINT COLOR		

TYPE C

SeangYong Motor Co., Ltd.			
1		kg	kg
2		kg	kg
BODY PAINT COLOR			
DATE OF MANUFACTURE			
<small>Seangyong European Parts Center B.V. Contact address: BMC 520 & 526, 40-5400 Breda, The Netherlands</small>			

TYPE D

SeangYong Motor Co., Ltd.		
VEHICLE WEIGHT		KG
TOTAL WEIGHT (VEHICLE WEIGHT + TIRE WEIGHT)		KG
TIRE WEIGHT (PER SIDE)		KG
FRONT AXLE WEIGHT		KG
REAR AXLE WEIGHT		KG
DATE OF MANUFACTURE		
BODY PAINT COLOR		

The manufacturer's plate is attached to the driver's door sill (B pillar).

Vehicle Identification Number (VIN)

The vehicle identification number (VIN) is the identification number that includes vehicle model, manufacturing country and manufacturing year.



It is engraved on the front RH seat mounting member.

Visual Vin Label

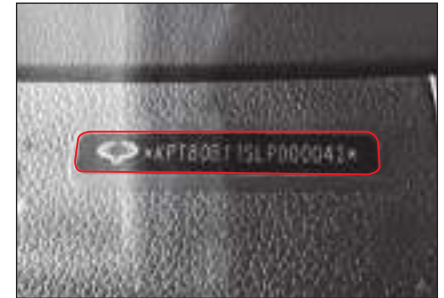

The VIN is stamped on top of the instrument panel.

Dimensions

Unit: mm

Front



Top



Rear



Side

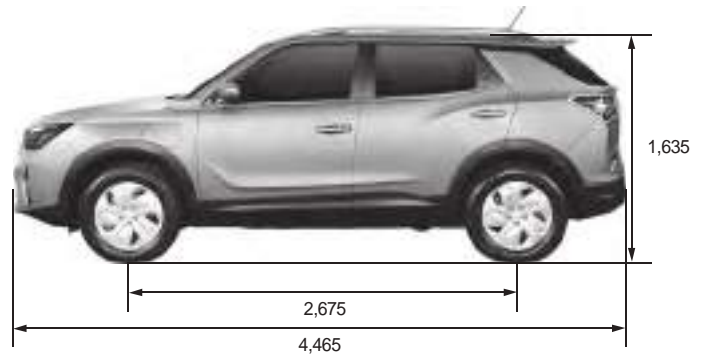

* (): Optional

1

SPECIFICATIONS

* () Optional

Descriptions		Specifications	
General	Overall length (mm)	4465	
	Overall width (mm)	1870	
	Overall height (mm)	1635 (1645: including roof rack)	
	Gross vehicle weight (kg)	2250	
	Curb vehicle weight (kg)	1765 (1822)	
Motor	Max. power	152.2kW	
Power Steering	Type	EPS	
	Steering angle	Inner	38,22
		Outer	32,12
Brake	Master cylinder type	Tandem type	
	Motor type	BLAC (Brushless AC)	
	Brake type	Front wheel	Disc
		Rear wheel	Disc
	Parking brake	EPB	
Suspension	Front suspension	Macpherson + Coil spring	
	Rear suspension	Multi link + Coil spring	
Air Conditioner	Refrigerant (capacity)	H/P	R-1234yf (750 ± 30g)
		Non H/P	R-1234yf (550 ± 30g)
Tire and wheel	Tier (specified tire pressure)	17in	215/65R17 (36 psi)
	Wheel	17in	6.5J X 17 (PCD* : 112)
Electrical	HV Battery Capacity (V-kw)	400 - 61.5	
	Low Battery Capacity (V-AH)	MF / 12 - 50	

* () Options, vehicle weights and gross weights are based on the maximum values and they depend on vehicle options and specifications.

Precautions for the modification of the vehicle and structural alteration

Warning

Unauthorized vehicle modification, structural alteration and installation of a component may cause car trouble or a fatal accident. Warranty repair will not be provided in case of product malfunction.

- The vehicle you purchased is made of a lot of precision parts passed through a large numbers of researches and tests, and these parts are linked and operate systematically.
- Modifying or changing any part arbitrarily or installing an unauthorized device may cause car trouble and affect the vehicle's performance, durability, and safety. It may lead to a fatal accident.
- Also, warranty repair will not be provided for a modified part as well as a problem that occurred due to the modification, even during the warranty period.

Do not install a separate accessory or auxiliary device to the vehicle operation device arbitrarily.

- Extending the SBW (shift by wire) or installing accelerator pedal or brake pedal pads available in the market arbitrarily may cause an operation mistake due to a change in the operating force of the vehicle. In such case, vehicle damage as well as a serious fatal accident may occur.

Warning

Do not modify the high-voltage system.

- Do not modify the charging cable and high-voltage system or service the vehicle without permission. The vehicle may malfunction, leading to unexpected hazardous situations (such as fire, electric shock, injury).
- Failure to use genuine parts or arbitrarily retrofitting can damage high and low voltage power systems.

Do not modify the audio system or install additional electronic devices such as wireless communication equipment, rear view camera, TV, and remote starting devices.

- The electrical system of this vehicle consists of electric wires and fuses for installing standard electronic devices.
- Connecting a number of electric wires to the existing wire for installing various additional electronics may cause overloading, resulting in damage to electronic devices and a risk of fire.
- In addition, drilling for installing an antenna may cause the vehicle to rust.

Warning

Do not install non-standard tires or wheel-related parts.

- If you install wider or larger tires than the vehicle specifications, the tires and adjacent parts may come into contact with each other and result in wear and damage to the power train system when you operate the steering wheel or drive on an unpaved road.
- In addition, the degradation of driving performance may occur due to an increase in the fuel consumption and braking distance, vibration of the vehicle body, and degraded handling of the steering wheel, and an impact may occur when shifting with the automatic transmission.
- Moreover, it may affect the speedometer and odometer, displaying an incorrect driving speed or a driving distance longer than the actual driving distance.
- If you install a wheel dust cover in order to improve the appearance of the tires, friction heat generated during braking is not released smoothly, causing the fade or vapor lock phenomenon. This may lead to the degradation of braking performance and cause a serious problem.

 Warning

Do not install a sunroof available in the market or replace with colored glasses arbitrarily.

- If you cut the roof of the vehicle and install a sunroof, rust or water leaks may occur in the cut part.
- Installing colored glasses to improve the appearance and block UV rays after the vehicle is shipped may cause water leaks. Do not install such glasses.

Do not modify the floor inside of the vehicle arbitrarily.

- Do not install an auxiliary article such as floor coverings on the floor inside the vehicle to enhance the cushioning or convenience for cleaning. Doing so may damage the operating device of various electronic systems and electrical wires, and hinder the function of the seat rail that moves the seat forward and backward.
- Also, the locking system to fix the position of the seats may not operate properly. In such case, the seats may move forward or backward, causing an accident, when driving on a downhill road or an uphill road.

 Warning

Do not replace the seat with a new one with a different function, or install a separate seat cover.

- There are various types of seats according to the function and role even for the same vehicle type and electric wiring has been applied accordingly.
- Do not bring and over-use or modify an adjacent electrical wire in order to replace a seat with a new one with different functions. In such case, it may damage electronic devices and create a risk of fire due to overloading.
- Replacing a seat cover incorrectly may damage electrical devices due to a short circuit or disconnection, or cause poor ventilation, fire and abnormal noise.

Do not install a bumper guide or a guide bar available in the market.

- If you install a bumper guide or a guide bar arbitrarily, problems such as difficulty in parking and stopping due to an increase in the total vehicle length, the waste of fuel due to an increase in the vehicle weight, and the occurrence of rust on the installation holes may occur. In addition, more serious injury may occur in the event of a collision accident due to the absence of a shock absorber in the bumper guide.

 Warning

Do not attach a functional product that may decrease the driving resistance such as stickers, molding, air dam, or windproofing products.

- Adhesives of the stickers may damage the coated surface of the vehicle. When drilling is carried out on the vehicle in order to attach molding and other functional parts, the drilled area may rust or abnormal noises may occur while driving.
- Especially if such parts are not attached firmly, such parts may fall off while driving, causing damage to the vehicle as well as a fatal accident.

Checking before driving

Daily inspection



- Check the vehicle once a day before driving.
- Check the coolant, brake fluid, washer fluid, and belts for abnormality.
- Check for leaks from the battery and the radiator.
- Check the bottom of the vehicle to see if there is an oil or liquid leak.
- Clean the front and rear windshields, rear glasses, side mirrors and room mirror.
- Check the operating status of the various lamps.
- Make sure that there are no obstacles that may hinder the driving around of the vehicle.

Checking motor room

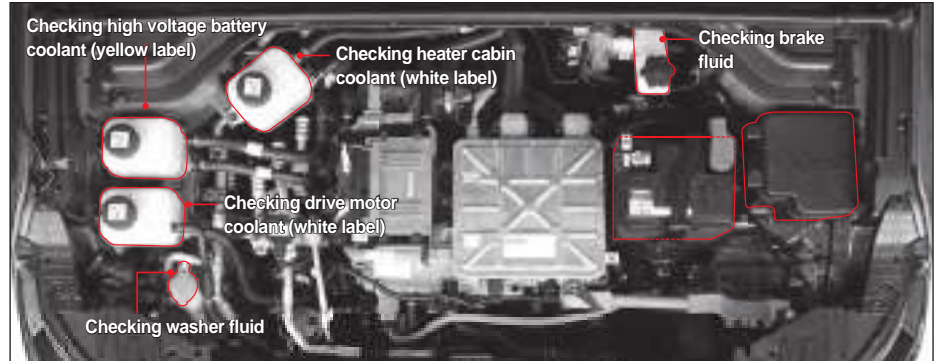

Checking coolant

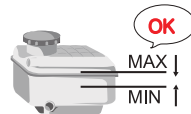

- Check the coolant after cooling the properly on level ground.
- Check that the coolant level is between the maximum mark (MAX) and the minimum mark (MIN) inside the coolant auxiliary tank.
- Mixing coolant and replenishing water can cause problems in the vehicle. So, if the coolant level is close to or below the minimum mark, have the system checked and serviced by a KG Mobility Authorized Service Center.

Checking brake fluid

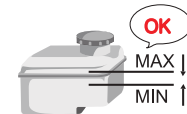

Check that the brake fluid level is between the maximum mark (MAX) and the minimum mark (MIN). If the level is close to or below the minimum mark, have the system checked and serviced by a KG Mobility Authorized Service Center.

When topping up the brake fluid, see Brake fluid level check and replenishment in page 6-10.

Checking washer fluid

Check the level of washer fluid on the washer fluid tank and add as needed.



Caution

- If the level of coolant and various oils drops below the “MIN” mark, have your vehicle checked by KG Mobility Authorized Service Center.

Checking tires



Warning

- **Maintain the tire pressure in a proper condition. Driving the vehicle at a high speed with low tire pressure may cause the tires to burst due to the standing wave effect, resulting in a risk such as a rollover.**
- **Check to see if the wheel nuts (bolts) are tightened. Improperly tightened wheel nuts (bolts) can cause an accident.**
- **Using wheel and tire other than the specified sizes could cause unusual handling characteristics and poor vehicle control, resulting in a serious accident.**
- **The use of tire sizes other than the specified sizes may cause abnormal operation of the steering wheel, increased fuel consumption, increase braking distance, vibration, improper operation of ABS/ESC, or uneven tire wear. It may also damage to the powertrain of the vehicle.**
- **Use only the same tires from same tire manufacturer for all the wheels.**

- Always check the tread and side of the tires to see if there is a sign of wear, cracks, or damage.
- Check the conditions of the emergency puncture service kit. The air compressor and sealant canister should be available at any time.
- Check the tire inflation and wear everyday and replace if necessary.



What is the standing wave phenomenon?

The standing wave phenomenon is the occurrence of a wave-shaped wrinkle on a tire with insufficient inflation pressure during high speed driving.

During driving, a tire that has normal inflation pressure repeats compression and restoration, but when a tire with insufficient inflation pressure rolls on the road with high speed, the tire will be compressed significantly and it comes into contact with the road surface again before it is fully restored. If such a situation occurs repeatedly, the standing wave phenomenon will appear.

If the standing wave phenomenon persists, a significant amount of heat is generated on the tire and the tire will be blown out in the end.

Checking the instrument cluster



Check if all the indicators and warning lamps are displayed correctly on the instrument cluster with the ignition switch in ON position.

Also, check if all gauges are operating properly.

Checking the parking brake



Operate the EPB (Electronic Parking Brake) switch and check the operating sound and operation status.

If the parking brake is not applied, have the vehicle checked and repaired by a near-by KG Mobility Authorized Service Center.

1

Checking the pedals

Check the operation status of the brake pedal and the accelerator pedal.

If the operation status of the pedal is abnormal in comparison to its normal status, have it checked and repaired by KG Mobility Authorized Service Center.

Cleaning up near the driver's seat

Keep the space near the driver's seat clean all the time. Never leave any object that hinders driving.

Always clean up the space near the driver's seat before driving.



Warning

- An empty bottle or an article below the pedal hinders the pedal operation and may cause an accident.
- If the floor mat is not fixed or is too thick, it may hinder the pedal operation and cause an accident.

Advisable driving position



Maintain an advisable position for safe and comfortable driving.

- Sit upright on the driver seat with the hip against the seat cushion.
- Adjust the position and height of driver seat in a way that the brake pedal can be depressed to the end comfortably.
- With your back against the seat back, adjust the position and height of the seat back and steering wheel so that you can rest your wrists on the top of the steering wheel.
- Adjust the height of the headrest in a way that the center of the headrest is aligned with the driver's eye level.



Warning

- Do not wear shoes such as slippers or high heels that may hinder driving. Such shoes may hinder the accelerator pedal or brake pedal operation and cause an accident.

Adjusting the seat, headrest, steering wheel, and mirrors

- Adjust the seat, headrest, steering wheel, and mirrors before driving the vehicle.
- If your steering wheel is adjustable, adjust it to an appropriate height and angle that fits your body and drive the vehicle.
- Adjust the rear glasses, side mirrors and room mirror to an angle that you can see the rear view well.



Warning

- If an additional adjustment is necessary while driving, make sure to stop the vehicle at a safe place and make the adjustments. Adjusting while driving may hinder driving, causing an accident.

Wearing the seat belt correctly



- Make sure that all occupants inside the vehicle wear a seat belt.
- Wear the seat belt with your body closely against the seat cushion.
- A child who cannot wear a seat belt should be seated in the rear seat using child restraints.
- For a vehicle where an adjustable top shoulder strap fixing device is provided, wear the seat belt by adjusting the shoulder strap control device to your body type.

Warning

- Do not wear the seat belt under the arm.



- Each seat belt is for one person. Two or more persons should not wear one seat belt together.



- Do not lock the seat belt with a clip or a clamp.



- Insert the seat belt latch only to the relevant buckle.



Safety and cautions for driving

Danger

No drugged, drunk, distracted and drowsy (4D) driving



- Avoid drugged driving. It is an illegal act that may be more dangerous than drunk driving depending on the type and dosage of a drug.
- Avoid drunk driving. Judgment is impaired under the influence of alcohol, making safe driving impossible. It is also an illegal offense that puts the life of occupants in other vehicles in danger.

Danger

- Avoid distracted driving. Using a mobile phone or the navigation system, watching DMB, or eating while driving may decrease your concentration, making a risk of an accident higher. In particular, using a mobile phone or watching DMB while driving is an illegal offense that hinders safe driving. When it is inevitable, stop or park the vehicle in a safe place and use the relevant device.
- Avoid drowsy driving. Driving for a long period of time without taking a rest will lead to drowsy driving that may cause an accident. Take a rest at least every 2 hours for safety.

Warning

Cautions for air bag

- The air bag system is an auxiliary safety device. Wearing the seat belt properly can minimize injury.
- Do not apply impact to the air bag by hand or with other articles. Doing so may cause the air bag to deploy.
- Do not place any object on, or attach a sticker or other accessories to the air bag inflation location where the air bag is installed. You may be injured by those objects during deployment.

Warning

- A passenger who is smaller than 140 cm should sit in the rear seat. Otherwise, the passenger may get injured during deployment.
- A safety device for infants and children should be installed on the rear 1st row. Installing it on the front seat may cause a serious injury or death if the air bag is deployed.
- A pet should be restrained in the rear seat using a dedicated safety device. A pet in the front seat may get injured if the air bag is deployed.
- When the air bag is deployed, the relevant components may be hot.
- A deployed air bag cannot be used again. Please replace it.
- The air bag system should be checked or replaced after 10 years from its installation even if the system has no abnormality. The air bag system should be checked or replaced by a professional technician in KG Mobility Authorized Service Center.
- Do not modify any part of the air bag system arbitrarily. Do not attach any other electrical device to the air bag system.

Warning

Precautions for infants, children, old people, or pregnant women



- Never leave an infant, a small child or an old person unattended in the vehicle. They may touch a device inside the vehicle, resulting in an accident. When the doors are locked and the windows are closed during summer, the temperature inside the vehicle will increase, resulting in suffocation.
- Do not allow children to use the ignition key, various switches or buttons, and additional devices without permission. Failure to do so may cause car trouble or even an accident. Their body may get caught in the door, window, or sunroof, and receive injury.
- Do not let an infant, a child or an old person sit in the front seat. The impact from the air bag expansion may cause serious injury or death. An infant or a small child should be restrained with a seat belt or protective gear in the rear seat attended by an adult.

Warning

An infant or a small child must be seated in the rear seat with protective gear



- An infant or a small child should be seated in the rear seat with an adult.
- An infant or a small child should be restrained with a seat belt or proper protective gear. Failure to do so may cause serious injury or death in the event of sudden braking or a collision accident.
- Apply the child protection lock system to the rear doors so that children in the rear seats cannot open the rear doors.

 Refer to "Child safety door lock" (p.3-4)

Warning

No sleeping in a sealed vehicle



- Never sleep in a parked car with all the windows closed. In particular, if you sleep with the air conditioner or heater turned on, you can suffocate to death due to a lack of oxygen.
- There is a risk of suffocation if you sleep in an enclosed area with the ignition turned on.
- While sleeping, you may accidentally touch the SBW (shift by wire) or accelerator pedal and cause an accident.
- If you step on the accelerator pedal continuously while sleeping, the motor and the drive system may be overheated, causing a fire.

! Warning

Do not drive with the doors or tailgate open



- Do not drive with the doors open. An occupant may fall out of the vehicle and suffer a serious injury.
- If you accidentally operate the door lever while driving and the door is open, it may cause a risk of a serious accident. In particular, do not allow a small child to touch the door lever while driving.
- If you drive the vehicle with the tailgate open, an article from the inside of the vehicle may fall out, causing an accident.

! Warning

Do not hold a part of your body out of the window or sunroof



- While driving or stopping, do not hold a part of your body such as a hand or head out of the window or sunroof. You may get injured by a passing vehicle or an obstacle.
- In particular, do not allow a child or a pet to hold their hand or head out of the window.

! Warning

Be careful not to have a part of your body caught when using the power window



- Use the power window only after checking that all passengers are safe.
- Before closing the window, check if a part of a passenger's body such as a hand or head is held out of the window and notify them that you will close the window.
- If a small child is seated in the rear seat, press the window lock switch to make the rear window switches inoperative.
 Refer to "Rear seat window lock function" (p.3-19)

! Warning

Check for any vehicles or persons passing by when getting out



- When you get out, make sure to check the rear and the front of the vehicle to see if there is any vehicle or person passing by. In particular, opening the door without checking a vehicle or a motor cycle approaching from the rear may cause damage to the vehicle as well as injury.
- Warn other passengers to check around before opening the door.

! Warning

Safe parking and stopping

- Never leave an infant or a child unattended in the vehicle with the doors and the windows locked after parking or stopping the vehicle. The temperature inside the vehicle may rise, resulting in suffocation or an accident.
- Always apply the parking brake while parking or stopping. Even a flat area may have a slope. Place the SBW (shift by wire) in the P (parking) position and always apply the parking brake.
- Do not stop or park on a steep road. The brake system may be released, causing the vehicle to move.
- When parking, be sure to apply the parking brake.
- When you park on a hillside road, make sure to apply the parking brake and place blocks under the wheels or adjust the wheels to face the wall.
- Do not stop or park the vehicle in places with flammable substances. The heated motor room and the high voltage battery may cause a fire.
- If the rear part of the vehicle is too close to the wall with the ignition turned on, there is a risk of discoloration or fire due to vehicle heat. Keep enough distance from the wall.
- If possible, do not park the vehicle in a humid area or a poorly ventilated area.

! Warning

Do not stop the vehicle while driving

- Do not stop the vehicle while driving. Doing so may make the steering wheel heavier and lower the brake performance, becoming very dangerous.
However, if you need to stop the vehicle in an emergency situation while driving due to an accident or a vehicle damage, refer to the following.
 Refer to “Stopping the vehicle while driving (in the event of emergency)” (p.4-5)

No sudden starting, acceleration or braking

- Do not start, accelerate, or brake the vehicle suddenly. Doing so may increase the high voltage battery consumption or cause an accident.
- Accelerate or decelerate the vehicle gently.

Driving on unpaved and mountain roads

- Before driving, check road conditions in advance to see if the road ends suddenly, or if there is enough space to make a U-turn for emergencies.
- In sandy or dry roads with much soil, the vehicle may slide easily. Keep your speed low and steady.
- Drive carefully on mountain roads, since the outer part of the road has a danger of collapsing.
- When driving downhill, downshift, and drive slowly by applying the engine brake.



Warning

In high mountain area

- Never charge the SOC of a high voltage battery above 90% in high altitudes, such as in mountainous areas.

Driving on a snowy or icy road

- If possible, drive slowly.
- Since the braking distance is longer than usual, maintain a proper distance from the car ahead.
- Accelerating or braking suddenly may cause your vehicle to slide, resulting in an accident.
- Use regenerative braking after slowing down sufficiently when driving on frozen or slippery roads. Sudden regenerative braking may cause the vehicle to slip and cause an accident.
- Use snow tires for safer driving when driving on a snowy or icy roads.



Warning

Driving on a sandy or muddy road

- Keep your speed as low and steady as possible.
- Accelerating or stopping suddenly while driving may cause the vehicle to be caught in the sand or mud.
- If the vehicle is caught in the sand or mud, place a stone or a wooden plate below the wheels and drive off from the sand or mud. Or, depress the accelerator pedal slowly and drive off using inertia by forwarding and reversing repeatedly.
- If you depress the accelerator pedal excessively to drive off from the sand or mud, the tires may slip, causing damage to the decelerator and motor systems. If possible, have your vehicle towed by another vehicle.



Warning

Driving on a hillside road and downhill road

- Downshift in accordance with the road conditions.
- Use regenerative braking (increase regenerative braking with paddle shift lever) with the brake pedal on long downhill. Applying the brake pedal continuously on a long downhill road may overheat the braking system, lowering the braking performance and resulting in an accident.
- When driving downhill after fully charging the high voltage battery, the regenerative braking system may not work. This may cause braking slippage during downhill driving, so be sure to drive at a low speed.

 Warning

Driving on a road with a pool of water or a river

- Avoid crossing a road with a pool of water or a river if possible. If water gets into the electric systems, it may cause serious damage to your vehicle.
- If you need to cross a road with a pool of water or a river unavoidably, select a shallower part where the lower part of the vehicle will not be submerged under water and cross slowly at a constant speed.
- Before crossing a river, get out of the vehicle and check the bottom of the river. Do not cross through a place where the bottom is sandy or covered with big rocks.
- If several vehicles cross the river together, the path where the vehicle ahead has crossed may have caved in. Cross through a different path if possible.

Cautions for crossing

- If the vehicle stops while crossing a road with a pool of water or a river, do not restart, and have your vehicle towed.

 Warning

Checking the vehicle after crossing

- If water gets into brake-related equipment, the brake performance will be lowered. After crossing a road with a pool of water or a river, drive slowly and depress the brake pedal slightly several times. Drive normally after drying the brake discs with the frictional heat and checking the braking performance.
- Check the parts at the bottom of the vehicle where oil and fluid are injected. If you discover any problems, have your vehicle checked immediately.
- Check the lamps and other electrical devices and replace them if necessary.
- Check for any damage on the vehicle body or at the bottom of the vehicle. If you discover any problems, have your vehicle checked immediately.
- If your vehicle is heavily soiled, wash your vehicle to protect the vehicle body.

 Warning

Do not use a cellular phone or watch DMB while driving

- Using your cellular phone or watching DMB while driving will distract yourself and may cause an accident. If necessary, pull over your vehicle safely to use your cellular phone.

 Warning

Driving on the expressway

- Before driving, check the weather information in advance, and check the high voltage battery charging amount, brake system, cooling system, level of tire wear and pressure, and maintain the vehicle thoroughly.
- Drive slowly for 2km after starting if possible.
- Always observe the speed limit and do not drive too fast.
- Keep a proper safe distance from the vehicle ahead.
- In case of bad weather, maintain more than twice the safe distance from the vehicle ahead than usual and reduce the speed by more than a half.
- Do not load the vehicle with unnecessary articles.
- Check and maintain the vehicle periodically to maintain the best vehicle condition.

Crossing an intersection or railroad crossing

- When you cross an intersection or railroad crossing, stop first, check for safety, and then cross promptly using a lower gear, without shifting if possible.
- If the vehicle stops in the middle of an intersection or railroad crossing, move the vehicle to a safe place promptly. If necessary, ask people around for help.



Warning

No sudden maneuvering of the steering wheel

- If you maneuver the steering wheel suddenly, the driving condition of the vehicle may become unstable, causing the risk of an accident.

To use regenerative braking

- Do not only apply the foot brake on long downhills, but also use regenerative braking (increase regenerative braking with paddle shift lever).
- Using the foot brake excessively may cause the fade or vapor lock phenomenon due to overheating of the brake system, lowering the braking performance.
- When driving downhill after fully charging the high voltage battery, the regenerative braking system may not work. This may cause braking slippage during downhill driving, so be sure to drive at a low speed.

What is the fade phenomenon?

The fade phenomenon is the reduction of braking force due to a decrease in the friction force caused by a temperature increase in the friction surface of brake when the brake is applied excessively on a long downhill road.

What is the vapor lock phenomenon?

The vapor lock phenomenon is the condition that when the brake is applied excessively on a downhill road, bubbles form in the brake fluid in the wheel cylinder or brake pipe of the hydraulic brake so that proper hydraulic pressure cannot be transferred, causing the brake system not to operate properly even if the pedal is depressed.



Warning

Cautions for attaching accessories

- Do not attach accessories or unnecessary articles to the vehicle windows. They may interfere with your driving, and if attached accessories act as a lens (magnifying glass), a fire or an unexpected accident may occur.

Special cautions when checking the coolant

- Never open the coolant reservoir cap when the motor room is hot. Doing so may cause hot steam or coolant to erupt, causing burns on your body parts including the hands or face.

Do not load hazardous materials

- Do not store any flammable materials such as gasoline, butane gas, or a disposable gas lighter, or explosive materials inside the vehicle. If the indoor temperature rises, the container may burst, causing a fire.



Caution

Cautions for vehicle ventilation

- For a new vehicle purchased within 1 year, harmful volatile organic compounds (VOC) to human body may be emitted in the cabin. In particular, riding a vehicle exposed to direct sunlight for a long period of time or without proper ventilation may cause headache, dizziness or nausea.
- Operate the fresh air inflow mode or open the windows periodically to ventilate air inside the vehicle for the health of passengers and a pleasant vehicle environment.



Caution

System protection function (delayed accelerator pedal response)

- Do not depress the brake pedal while driving with the accelerator pedal depressed (both feet driving). Doing so may affect the vehicle driving system and the response from the accelerator pedal may be delayed.
- This symptom is a safety function to protect the vehicle system. This symptom will disappear if you depress and release the accelerator pedal once with the brake pedal not depressed.

Placement of extinguisher

- An extinguisher is an essential item for early extinguishing when a fire occurs. It is recommended to purchase it from a fire-fighting appliance store and place it in the vehicle.

KG Mobility Authorized Service Center and maintenance partners

KG Mobility Authorized Service Center or maintenance partners for checking and repairing the vehicle. If you use other service centers or maintenance shops, warranty repair will not be available and warranty will not be provided for any consequent problems.

Cautions for the depletion of battery when connecting uninterruptible power supply to the black box system

If the vehicle is not operated for a long period of time with the uninterruptible power supply connected to the black box system, the vehicle battery may be depleted.

Turn off the black box system if you will not drive the vehicle for a long period of time.

Breaking in a new vehicle correctly

Break-in is not required for a new vehicle. However, the driving condition for the first 1,000 km significantly affects the life and performance of the vehicle. Pay attention to the following when driving during this period.

- Do not speed, accelerate, brake suddenly.
- Shift properly according to driving speed.
- Do not overload the vehicle while driving a sloping road.
- Do not tow a trailer during the first 1,000 km.
- During the first 1,000 km of towing a trailer, do not drive at a speed over 80 km/h or with full acceleration.

Long-term parking mode

This mode is for preventing vehicle battery discharge. Set it on the instrument cluster and use it if necessary.

During setup, smart key search is stopped to minimize power and some functions are limited.

Using genuine parts

Always use genuine parts for maintaining safety and the best performance of your vehicle. Warranty repair will not be provided for car trouble caused by using a non-genuine part.

You can verify a genuine part by its hologram and sticker with the product number.



Caution

- **The warranty does not cover problems caused by using non-KG Mobility genuine parts.**
- **You can distinguish an authentic KG Mobility genuine part by its hologram.**

Vehicle washing

After driving on a coastal road (salty road), a road where calcium chloride was spread, an area with excessive smoke or coal tar, or a muddy or dusty area, or when the vehicle is stained with tree sap or insects' or birds' droppings, wash the vehicle immediately since corrosion may occur on the vehicle body.

- Avoid direct sunlight and wash the vehicle in the shade. If your vehicle has been parked under direct sunlight, let it cool properly before washing.
- Dust off the vehicle with cold water.
- Mix cold water with detergent in a bucket and wipe the vehicle from top to bottom using a soft brush, sponge, or cloth.
- Wash off any foreign materials on the vehicle body without damaging the painted surface.
- Any scratched or damaged painted surface causes corrosion, so repair them with paint for repair.
- Remove moisture using a dry and soft cloth.
- After washing, drive the vehicle normally after driving it slowly, and checking the operating status of the brakes.

Caution

- Be careful not to damage the air spoiler when cleaning the vehicle in an automatic car wash.
- When washing with water (including high pressure washing) on the underside of the vehicle or high voltage, etc., be careful not to get moisture into various sensors or high voltage connectors. Our warranty will not be provided for any consequent failure.
- Avoid washing with water when the brake discs are hot. Hot brake discs may be deformed or damaged if it comes into contact with water.
- If possible, avoid high pressure washing for maintaining and managing the vehicle performance.
- High pressure washing may damage the components and sensors installed on the exterior of the vehicle and the painted surface of the panels. In particular, be careful not to get water into the electrical devices and sensors at the bottom of the vehicle.
- When you use high pressure washing unavoidably, maintain a proper distance between the high pressure water nozzle and the vehicle. If the distance is too close, the sensors on the bumper may malfunction or the painted surface of the panels may be damaged due to the high water pressure.



- Do not use abrasive wax and strong cleaning materials such as steel wool which will scratch the vehicle body and bumper.
- Do not clean the inside of the motor room with liquid substances such as water or wax. Liquid substances may enter electrical devices (sensors and high voltage system) inside the motor room, which may prevent the vehicle from operating due to malfunction of various electrical devices and malfunction of the high voltage system.

Washing the bumper

- Wipe off foreign materials using a soft sponge.
- If the bumper is contaminated by oil or any lubricants, wash it off using soapy water.



Caution

- **Do not use abrasive wax or a brush to wipe the bumper or the vehicle body. Doing so may damage the bumper or the surface of the vehicle body (painted surface).**

Washing wheels

Clean the wheels after driving on a salty road to prevent the wheels from being corroded.



Caution

- **Do not use abrasive cleaners, polishes, solvents, wire brushes, and high speed washing brushes since they may damage the wheel surface.**
- **Using acid or alkaline detergents could damage the wheel surface (painted surface), so use neutral detergents for cleaning the wheels.**
- **Using strong cleaners may discolor the wheel surface. Make sure to use natural cleaners. A discolored wheel due to carelessness is not subject to free warranty repair.**

Cautions for polishing the vehicle

- Before waxing, remove dust or moisture from the vehicle.
- Apply a small amount of wax on a soft cloth, apply it to the whole vehicle body evenly, and scrub a wide area in the same direction to polish.
- After waxing, remove residual wax from the vehicle body completely.



Caution

- **Do not polish or wash the vehicle body using wax containing abrasives. Doing so may damage the surface of the vehicle body (painted surface).**

Cleaning and maintaining glass

- Clean the indoor and outdoor sides of glass windows using a glass cleaner and a soft cloth.
- When cleaning the glass windows, be careful not to damage the electric demister element.
- When automatic car washing is used, coating (wax) substance included in the cleaning fluids may adhere to the glass surface and it may not be wiped off easily when it is dried. Spray washer fluid and operate the wipers two or three times to remove coating (wax) substances using the cleaning substances included in the washer fluid.
- Do not wipe the glass surface with a towel stained with oil or wax. Doing so may cause vibrations and abnormal sounds when the wipers are operating and the front and rear windshields may not be cleaned properly when it rains. Also, the reflection of light may occur at night, causing poor visibility and affecting safe driving.

Cautions for window tinting

- All vehicles from our factory have tinted windshields and rear windows that meet the specified percentage of visible light transmission (VLT). Do not tint the windows of the product. Doing so will lower VLT, becoming subject to legal regulation.
- Tinting the windshield and rear window excessively may reduce front and rear visibility at night or in case of rain, causing an unexpected risk.
- When tinting the windshield and rear window, do not allow working solutions to enter into electrical and electronic devices. Failure to do so may cause a malfunction or failure of electrical and electronic devices.
- If the windshield and rear window are modified or tinted arbitrarily, the electric demister element may be damaged by a knife or a tool or an electrical shock.
- If the windshield and rear window are coated or tinted (metallic tinting film), the Hi-Pass system, rain sensor, and radio may not operate normally.
- Do not tint the front camera sensing part. Otherwise, the relevant system may malfunction.

Care and cleaning of the interior

- Use a dry towel for normal cleaning.
- For synthetic resin such as plastic, clean it with lukewarm water and soap and wipe off with a wet towel with no soap.
- Wipe using a dry towel to dry.
- Remove dust on the seats and mats using a vacuum cleaner.
- If the mats are heavily stained, spray a cleanser on them and wipe using a cloth.



Warning

- **To prevent from burning and electric shock, turn off the interior lights before cleaning the vehicle interior.**



Caution

- **When you use chemicals for cleaning the interior, the color or shape of the interior may change.**
- **Do not use chemical products such as acetone, enamel, and bleach for cleaning the interior.**
- **The Leather Seat Maintenance is necessary on Quarter basis with dedicated Leather Milk or Cream in order to feed the Leather and avoid any cracks on the seats and conserving the original look and comfort of the seat.**

Seat Belt Care

- Keep belts clean and dry.
- Clean seat belts only with mild soap and lukewarm water.
- Do not bleach or dye belts since this may severely weaken them.

Cautions for using the vehicle key

- Be careful not to lose your key.
- If your key is lost or stolen, replace the whole key set to prevent the vehicle from theft.
- Do not throw or drop your key. Doing so will damage your key. Do not drop your key in water.
- Use only the same standard battery for the key and be careful not to switch the polarity when inserting the battery.

Corrosion protection

Your car was designed to resist corrosion. When it was built, special and protective finishes were used on most parts of your car to help maintain a good appearance, strength and reliable operation. Some parts which normally are not visible (such as certain parts located in the underbody of the vehicle) are such that surface rust will not affect their reliability. Therefore, corrosion protection is not needed or used on these parts.

Sheet Metal Damage

If your car is damaged and requires body panel repair or replacement, make sure the body repair shop applies proper anticorrosion material to the parts repaired or replaced so that corrosion protection is restored. (Also refer to "Finish Damage" on the next page).

Foreign Material Deposits

Calcium chloride and other salts, deicing agents, road oil and tar, tree sap, bird droppings, chemicals from industrial chimneys and other foreign materials may damage vehicle finishes if left on painted surface. Prompt washing may not completely remove all of these deposits. Other cleaners may be needed. When using chemical cleaners, be sure they are safe for use on painted surfaces.

Finish Damage

Any stone chips, fractures or deep scratches in the finish should be repaired promptly. Bare metal will corrode quickly and may develop into a major repair expense. Minor chips and scratches can be repaired with touch-up materials. Larger areas of finish damage can be corrected in your Distributor's body and paint shop.

Underbody Maintenance

Corrosive materials used for ice and snow removal and dust control can accumulate on the underbody. If these materials are not removed, accelerated corrosion (rust) can occur on underbody parts such as the fuel lines, frame, floor pan, and the exhaust system even though they have been provided with corrosion protection. At least every spring, flush these materials from the underbody with plain water. Take care to clean any area where mud and other debris can accumulate.

Sediment packed in closed areas of the frame should be loosened before being flushed. If desired, your KG Mobility Distributor can do this service for you.



Caution

- **Used brake fluid, decelerator fluid, antifreeze, batteries, and tires should be disposed by using the local authorized waste disposal facilities, or have them disposed of by the vendor who is under a statutory obligation to do so when you replace them.**
- **None of these items should be placed in the household recycling bins or poured into the sewage system.**
- **Everyone should be concerned about environmental protection.**
- **Help by doing your share.**
- **When a strong multi-purpose, acid, or alkaline detergent is used to clean up the surface of the painted body, side mirrors, windshield, plastic moldings or leather, changes, fading of colors or rusting can happen.**

- **When the windshield is cleaned with an oil-contained or waxed towel, strange sounds and vibrations may occur on the windshield surface when the wipers are operating. Also, decreased visibility, reflection at night, or poor removal of water on the windshield may happen. Do not clean the windshield with an oil-contained or waxed towel.**
- **An abrasive detergent may damage the painted surface of your vehicle, including the bumper. Do not buff or polish your vehicle with an abrasive detergent.**
- **An acid or alkaline detergent may damage the painted surface of the aluminum or alloyed wheels.**
- **When chemical products are used to clean up the interior, the chemical products may change some colors or distort the shape of some interior parts.**
- **When cleaning up interior parts, do not use chemical products such as acetone, enamel or bleach.**

High voltage warning lamp



The high voltage warning lamp is illuminated in the event of a failure of a sensor related to the electric vehicle control system or an abnormality in the cooling/heating system and etc.

This may result in reduced motor drive or ignition off.

If this occurs, have the system checked at the KG Mobility Dealer or KG Mobility Authorized Service Operation.

Other maintenance

After driving on a calcium chloride (salt) spayed road, wash the bottom of your vehicle as soon as possible to avoid any rust.

When parking on a snow-covered road, the brake system may begin to have some ice on it. The ice will decrease your vehicle's braking ability. If this happens, drive at a low speed and use the brake frequently to remove the ice. After regaining the braking ability, drive your vehicle at a normal speed.



Warning

- **When there is ice on the wiper blades, turning on the wiper switch may put an extra burden on the wiper motor and damage it. Avoid using the wipers when ice is on the blades.**
- **When driving on a snow-covered road, a large amount of snow may build up under each wheelhouse. This buildup prevents the steering wheel from moving freely. Therefore, remove the snow buildup frequently.**

2. Safety Units

You can check information regarding units that allow you to drive the vehicle safely and how to use such devices.

An explanation is provided for seat belts, a child restraint for an infant or a small child, airbags, anti-theft and warning system.

Seat belt

The seat belt is the most fundamental safety unit that protects an occupant and prevents or reduces injury when an accident occurs.

If you do not fasten the seat belt or fasten the seat belt incorrectly, the seat belt does not function properly and you may also get injured by the seat belt.



Warning

- All occupants must fasten their seat belt before driving. Failure to do so may lead to a fatal accident, in case of emergency or when the brake is applied suddenly.
- The air bag can ensure the safety only when the seat belt is fastened correctly. If the air bag inflates when you do not fasten the seat belt or fasten it incorrectly, you may get injured by the inflated air bag.

Seat belt warning

If the occupants in the driver seat and the front passenger seat do not fasten their seat belts, the warning lamp on the instrument cluster blinks along with a warning buzzer.

The rear seat (left, center and right) reminder illuminates the warning lamp or sounds the buzzer depending on the vehicle conditions and whether the seat is occupied or not.

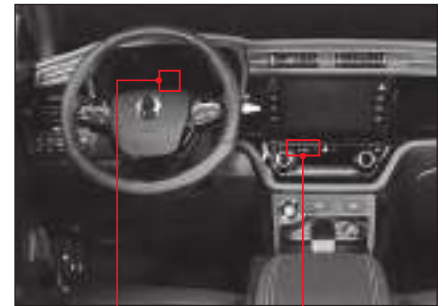

- 1 Warning lamp for driver and front passenger
- 2 Rear (left) seat warning lamp
- 3 Rear (center) seat warning lamp
- 4 Rear (right) seat warning lamp

Front seat (driver / passenger) belt reminder

- The seat belt reminder warning lamp and buzzer are triggered only when the ignition switch is turned on or the vehicle is started.
- If you turn the ignition switch on or start the vehicle with the seat belt not fastened, the warning buzzer sounds and warning lamp flashes for about 6 seconds. At this time, when the seat belt is fastened, the warning buzzer stops and the warning lamp flashes for the rest of the time.
- If you turn the ignition switch on or start the vehicle with the seat belt fastened, only the warning lamp flashes for about 6 seconds.
- If you fasten and then unfasten the driver seat belt, the warning buzzer sounds while the warning lamp flashes for about 6 seconds. However, for the passenger seat, the warning lamp and buzzer do not work even if the seat belt is fastened and then unfastened.
- When driving the vehicle at a speed of about 10 km/h or higher with the seat belt not fastened, the warning lamp comes on for about 100 seconds and the warning buzzer sounds. After 100 seconds, the warning buzzer stops and only the warning lamp stays on.

Rear seat (left / center / right) belt reminder*

- The rear seat belt reminder warning lamp comes on for 70 seconds when the ignition switch is turned on regardless of whether the seats are occupied or not and the warning buzzer does not sound.
- The rear seat occupancy sensor recognizes that the corresponding (left, center and right) seat is occupied when the rear seat belt is fastened and then unfastened with the ignition switch turned on.
- If the seat belt is fastened when the warning lamp comes on for 70 seconds by turning the ignition key on the corresponding warning lamp goes off.
- If the rear seat belt is fastened and then unfastened at a vehicle speed of 10 km/h or less, the corresponding warning lamp stays on until the seat belt is fastened. At this time, the warning buzzer does not sound.
- If the rear seat belt is fastened and then unfastened at a vehicle speed of 10 km/h or higher, the corresponding warning lamp keeps flashing until the seat belt is fastened and the warning buzzer sounds for 70 seconds.
- The rear seat occupancy is reset when: the rear door is open and closed with the vehicle stationary (speed of 0 km/h) and ignition switch turned on.



Caution

- **The passenger seat belt warning operates only when an occupant on the front passenger seat is detected. When the occupant on the front passenger seat is positioned inappropriately or is too small, the occupant may not be detected.**
- **When an object is placed on the front passenger seat, the occupant detection sensor may operate and the passenger seat belt warning may operate.**
- **If the warning lamp or the warning buzzer persists after fastening the seat belt, have your vehicle checked and serviced at a KG Mobility Corporation Authorized Service Center.**

Notice

- **Seat belt warning may persist until the seat belt is fastened depending on the vehicle condition.**
- **When the SBW (shift by wire) is maintained at the R (reverse) position for 1.5 seconds or longer, the seat belt warning (reminder) does not operate.**

Fastening the seat belt

- 1 Sit upright on the seat with the hip against the seat cushion.
- 2 Hold the seat belt latch and pull it slowly in the direction of the buckle.

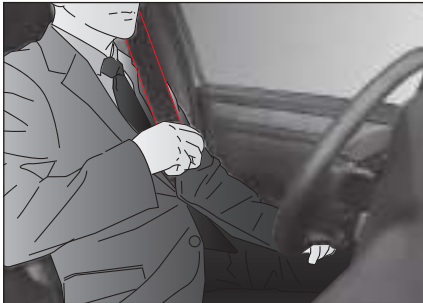

Warning

- Wear the seat belt in a way that it is not twisted. If the seat belt is twisted, it cannot distribute the impact at the time of an accident properly.

Notice

- If the seat belt is locked and does not move, loosen the seat belt a little bit and pull it slowly or strongly. In some cases, you have to pull the seat belt strongly for approximately 2 to 3 seconds to move it.

- 3 With the shoulder belt webbing positioned across the chest and the lap belt webbing positioned across the hips, insert the belt latch into the buckle until it clicks.

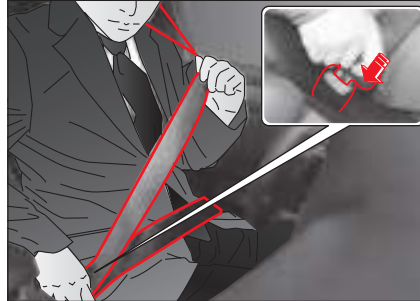

Warning

- Fasten the seat belt in a way that the shoulder belt webbing is positioned across the chest. If the shoulder belt webbing is positioned across the neck, a serious injury may occur by the belt in the event of an accident.
- Position the lap belt webbing as low as possible across the abdominal area. If the lap belt webbing is positioned across the abdominal area, an impact may happen in the event of an accident, resulting in a serious injury.
- Pull the belt latch to make sure that it is securely locked into the buckle.

- 4 Adjust the height of the shoulder belt webbing using the seat belt height adjuster if needed.
- 5 Adjust the belt webbing on the chest and the hips to not be slack.



Warning

- Do not fasten the seat belt higher than the body or loosely. Doing so may cause the body to slip below the seat belt in the event of a collision accident, resulting in injury.

Unfastening the seat belt

- 1 To unfasten the seat belt, press the red button on the buckle and separate the belt latch from the buckle.



- 2 Hold the belt latch and let the seat belt webbing to be wound slowly.

Managing the seat belt

Adjusting the height of the front seat belt

You can adjust the height of the shoulder belt anchorage to prevent the seat belt from being positioned across the neck.

Warning

- Adjust the height of the seat belt before driving.

- 1 With the top of the seat belt height adjuster pressed, raise or lower the seat belt holder.



- 2 Release it at the desired position.
The seat belt holder is secured.

Rear seat belt storage

If you do not use the rear seat belts or wish to fold the rear seat back, insert the seat belt into the webbing guide installed on the wall as shown in the figure.



Caution

- Remove from the webbing guide first if you wish to use the seat belt. Pulling the seat belt with the webbing guide inserted may damage the webbing guide or the seat belt.

Rear seat buckle storage

If you do not use the rear seat belts, insert the buckle into the buckle storage as shown in the figure.



Rear center seat belt storage

Have the auxiliary latch inserted into the auxiliary buckle always if you do not use the rear center seat belt.

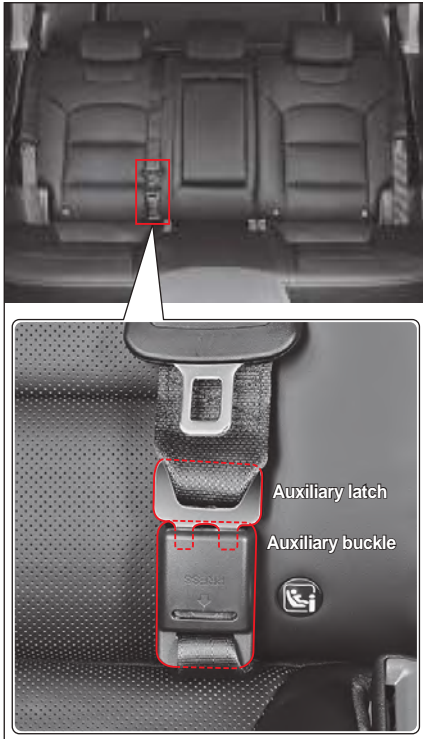

Rear center seat belt release

- 1 Press the auxiliary buckle hole (1) using the emergency key.



- 2 Hold the auxiliary latch (2) and left the seat belt to be wound slowly.

Warning

- If the auxiliary latch retracts at high speed, an adjacent occupant may get injured.
- Do not allow a child to pull and release the auxiliary latch repeatedly.

How to fasten the seat belts (2-point) in rear center seat

- 1 Pull out the latch plate at the bight of the seat.

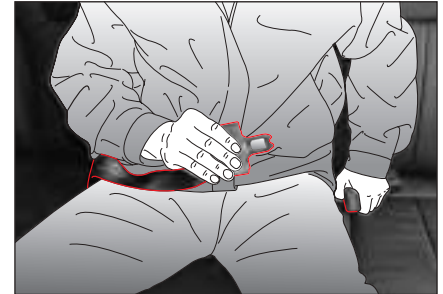

Warning

- Put the lap belt as low as possible across the hips. Do not put it across waist. In an accident, the belt may apply pressure to your abdomen. This may cause serious internal injuries.



To lengthen, hold the metal latch plate at a right angle to the belt and pull the belt. To shorten, pull the free end of the belt away from the latch plate, then pull the belt clip to take up the slack.

- 2 Insert the metal latch plate into the buckle until it clicks. Position the belt as low as possible across your hips, not across your abdomen.

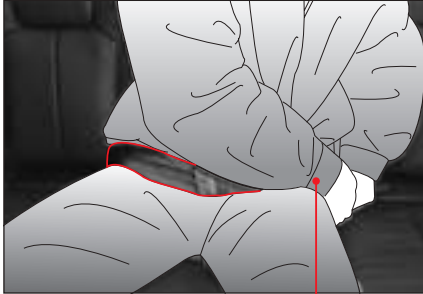

- 3 If the belt is too tight or slack on your hips, readjust the belt.
- 4 To unfasten the seat belt, press the red button on the buckle.

How to fasten the seat belt (3-point) in rear center seat

- 1 Pull out the latch plate from the retractor. If the seat belt is locked when being pulled out, rewind it completely in the retractor, then pull it out to the desired length.



- 2 Insert the latch plate into the right mini buckle until it clicks.

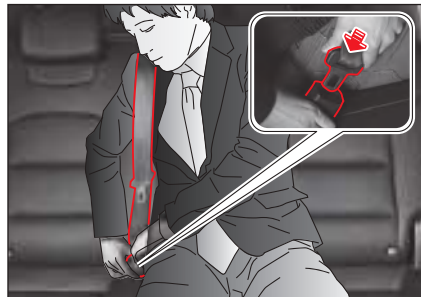

- 3 Position the shoulder belt across the body and the lap belt as low as possible across the hips. Insert the latch plate into the buckle until it clicks.
- 4 Pull the latch plate to make sure it is securely locked. A slack belt will greatly reduce the protection afforded to the wearer.
- 5 To unfasten the seat belt, press the red button on the buckle.

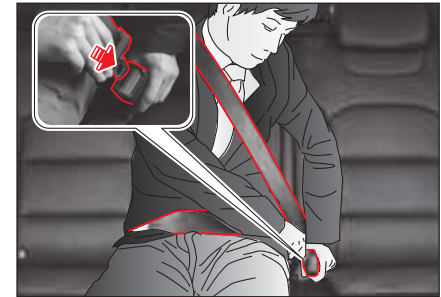

Warning

- Make sure to fasten the seat belt according to the order as described so that it functions properly.
- To prevent the seat belt from bumping against the rear glass, unfasten the seat belt while holding it.
- This seat belt is designed only for a passenger who sits on the center seat in the rear seat.
- Tug on the seat belt to make sure that the latch plate is securely locked.
- Make sure that the seat belt is not twisted.
- Improper wearing of seat belts increases the chance of injury or death in case of a collision.
- Position the seat belt away from your neck and abdomen.

Caution

- Stow the seat belt into the console when it is not in use.

Seat belt pretensioner and load limiter

The seat belt pretensioner and the load limiter are the units that operate at the same time when the driver and front passenger air bags operate, increasing the safety effect of the seat belt and the air bag.

Pretensioner

The seat belt pretensioner is a protection unit that draws back the seat belt on the occupant's chest and hips instantaneously and secures the occupant to the seat to prevent the occupant from bouncing forward in the event of a strong front collision.

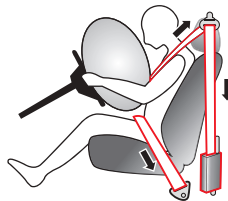

Danger

- The seat belt pretensioner is designed to operate only once. After it operates, replace the seat belt.

Load limiter

The seat belt load limiter is a protection unit that releases the seat belt right after a vehicle collision to prevent a secondary injury due to belt force.

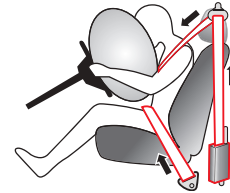

Fastening the seat belt by a pregnant woman

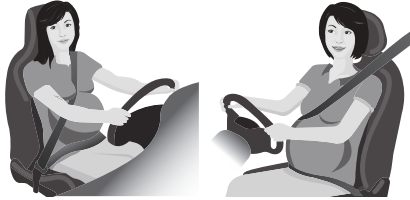

Warning

- It is dangerous for a pregnant woman to drive, so please avoid it if possible. If it is unavoidable, consult a doctor about the precautions and fastening the seat belt during pregnancy.
- Fasten the seat belt before driving. If an accident occurs without fastening the seat belt, may be dangerous for both the pregnant woman and the fetus.
- When a pregnant woman fastens the seat belt, make sure that the belt is not positioned across her abdomen. If the belt presses her abdomen, in the event of a vehicle collision or when applying a sudden brake, may be dangerous for both the pregnant woman and the fetus.

Warnings for the seat belt

Warning

Infants, small children, pregnant women or patients

- The child restraint should be used for an infant or a small child. In particular, please note that the three-point seat belt is designed for a person who is taller than 140 cm.
- In the event of a sudden stop or an accident while a pregnant woman or a patient is wearing the seat belt, strong force may apply to the abdomen or other body parts. Make sure to consult a doctor before fastening the seat belt.

Position and method to fasten the seat belt

- The seat belt is designed for only one person. Two or more persons should not share one belt.
- If the position of the seats is incorrect, it is impossible to fasten the seat belt correctly. Always adjust the position of the seats to their normal status for driving.
- Fasten the seat belt after keeping the seat upright and leaning the back against the seat backrest with the hip against the seat cushion. If the seat belt is positioned too high or fastened too loose, the body may fall out from the shoulder belt webbing or the lap belt webbing, resulting in a serious injury or death.

- If a strong impact occurs while the seat belt is fastened with the seat backrest reclined too much, the body may fall out below the belt, causing the belt to hang around the neck and result in a serious injury.
- If the seat belt is positioned across the neck, a serious injury may occur by the seat belt when an accident occurs. Make sure to wear the three-point seat belt in a way that the belt webbings are positioned across the chest and the hips.
- Do not pull your arm over the shoulder belt. Doing so prevents the seat belt from effectively blocking the body from bouncing forward in the event of a collision. A head or neck injury may occur accordingly and the impact is applied to the ribs that are weaker than the shoulder bone, causing a serious injury.
- When the shoulder belt webbing is positioned across the abdomen, the body may fall out below the belt or a great impact may be applied to the abdomen, causing a serious injury such as intestinal rupture.
- If the belt latch is inserted into another buckle that is not the relevant buckle, the safety belt may not fit the body correctly so that it cannot protect the body properly.
- In addition, if the lap belt webbing of the two-point seat belt is too loose or the seat belt is fastened incorrectly, just as fastening a twisted seat belt, a fatal injury may occur in the event of an accident.

No modification of the seat belt and no attachment of illegal fixtures

- A modified seat belt cannot guarantee safety. Never modify the seat belt.
- Inappropriate work on safety units may adversely affect or hinder the operation of the units. Be sure to have the safety units serviced at a KG Mobility Corporation Authorized Service Center that possess the required expertise, knowledge and special tools.
- If you attach an auxiliary device or accessory to the seat belt separately, the seat belt may not operate normally. Never attach any auxiliary device or accessory to the seat belt.
- Do not loosen the seat belt by locking it with a clip or a clamp. Doing so may cause a fatal injury due to a secondary impact in the event of a collision.

Checking and managing the seat belt and the importance of safe driving

- Do not allow foreign materials to enter into the seat belt buckle.
- If the seat belt and the relevant components are damaged, the seat belt may not operate normally. Check the seat belt frequently for any damage and the status of normal operation, and if any abnormality is discovered, have the seat belt repaired at a KG Mobility Corporation Authorized Service Center immediately.

- If a strong impact has been applied to the seat belt due to an accident, etc., make sure to have the seat belt checked and replaced with a new one as needed even if there is no abnormality visually. Also check and replace the retractor and the seat belt anchorage if there is an abnormality.
- Care should be taken to prevent the seat belt from being contaminated by polishes, oils, chemicals and especially battery acid. When cleaning, wipe the seat belt carefully using a neutral detergent and water. Replace the seat belt if the webbing is frayed, contaminated or damaged.
- Do not place a hard or sharp object in the clothes or a pocket where comes into contact with the seat belt.
- The seat belt can reduce serious injuries. However, it cannot block fatal accidents and injuries completely. Keep this in mind and drive safely.

Child restraint for an infant or a small child

For an infant or a small child who cannot wear the three-point seat belt, have the infant or the small child be seated in a rear seat using a child restraint for an infant or a small child whose quality is certified by the government.

If the infant or the small child sits in the front passenger seat, the infant or the small child cannot be protected from an inflated air bag or other impacts in the event of a vehicle collision.



Warning

Seating an infant or a small child

- Do not let an infant or a small child sit in the front passenger seat. Doing so may cause a serious injury or death due to the inflation impact of the front air bag in the event of a collision accident.
- Do not ride with an infant or a small child in your arms or sitting on your lap. Doing so may cause a fatal injury to the infant or the small child in the event of a collision accident.
- If an occupant who is smaller than 140 cm wears the three-point seat belt, the seat belt cannot function fully. In such case, install and use a child restraint that fits the physical condition of the occupant.

Installing the child restraint

- Never use a rearward facing child restraint on a seat Protected by an ACTIVE AIRBAG in front of it, DEATH or SERIOUS INJURY to the CHILD can occur.
- Use a child restraint for an infant or a small child that passed through the certification and the safety inspection carried out by a certified government agency. Follow the manufacturer's owner's manuals for the installation and precautions of the child restraint.
- If the child restraint for an infant or a small child is installed incorrectly, it may not provide the appropriate protection function. In such case, it may result in a serious risk when an accident occurs.
- If the child restraint for an infant or a small child is not secured completely, injury or death of an infant or a small child may occur in the event of a collision accident.
- Never install a rear-facing child restraint in the front seat with front passenger air bag.
- Install the child restraint for an infant or a small child on the left or right side of the rear seat where the three-point seat belt is installed. If it is installed on the front passenger seat, a fatal injury may occur when the air bag inflates.
- When installing the child restraint for an infant or a small child in the rear seat of a vehicle where a curtain air bag is installed, install it as far as possible from the door. Failure to do so may cause serious injury or death of an infant or a small child when the curtain air bag inflates.
- When the child restraint for an infant or a small child is installed on the rear seat where the three-point seat belt is installed, be careful not to position the seat belt across the neck or face of an infant or a small child.

Using the child restraint

- When the child restraint for an infant or a small child is used, observe instructions provided by the manufacturer. Failure to do so may cause a fatal injury when an accident occurs.
- After installing the child restraint for an infant or a small child, make sure to check if it is secured correctly.
- Make sure that the child restraint is secured correctly by pushing or pulling it in various directions before letting an infant or a small child sit in the child restraint.

Managing the child restraint

- Do not carry the child restraint for an infant or a small child in the vehicle without installing or securing it. Doing so may cause the child restraint to bounce, causing an injury to the occupants in the event of sudden braking or an accident.



Caution

- This information is to help in understanding the necessity and usage of the child restraint for an infant or a small child. Use this information for reference purposes.
- When the child restraint for an infant or a small child is used, install and use it according to the owner's manual provided by the manufacturer.

Infant and child safety

Child Seat

Children that are too small to use the seat belts must be properly secured in a child restraint system.

Warning

- Never install a rear-facing child restraint in the front passenger seat with front passenger air bag.
- Because of the danger that an inflating passenger air bag could impact the rear-facing child restraint and kill the child.
- Use only the qualified child restraint systems. Follow the manufacturer's instructions for installation and use of the child restraint systems.
- Do not carry your child on your lap while driving. You cannot resist against the impact pressure in an accident. The child could be crushed between you and the parts of vehicle.
- Remember that a child restraint seat left in a concealed vehicle can cause it to be very hot. Check the seating surface before putting your child in the child restraint.
- When your child restraint is not in use, remove it from the vehicle or keep it secured with a seat belt to prevent it from being thrown forward in case of a sudden stop or an accident.
- When installing a child restraint, do not let the seat belts come across the child's neck.

Table of Vehicle Handbook Information on Child Restraint Systems Installation Suitability for Various Seating Positions



Rear-facing child seat



Forward-facing child seat



TYPE A



TYPE B

Booster seat

Mass group	Restraint device figure	Front Passenger		Rear Centre ^{*1)}	Rear Out Board
		Air bag off	Air bag on		
O ~ up to 10 kg (0 ~ 9 month)	Rear facing child seat	U	X	U	U
O+ ~ up to 13 kg (0 ~ 2 year)	Rear facing child seat	U	X	U	U
I ~ 9 to 18 kg (9 month ~ 4 year)	Rear facing / Forward facing child seat	U	X	U	U
II ~ 15 to 25 kg (4 year ~ 6 years)	Booster seat	U	U	U	U
III ~ 22 to 36 kg (6 year ~ 12 years)	Booster seat	U	U	U	U

* Child restraint system are classified into the 5 groups according to the ECE R44

*1) Do not install a CRS with support leg in this seating position

NOTE:

U: Suitable for "universal" category restraints approved for use in the mass group.

UF: Suitable for forward-facing "universal" category restraints approved for use in the mass group.

L: Suitable for particular child restraints given on attached list. These restraints may be of the "semi-universal" categories.

X: Seat position not suitable for children in the mass group.

Table of Vehicle Handbook Information on ISOFIX Child Restraint Systems Installation Suitability for Various ISOFIX Positions

Mass group	Size Class	Fixture	Vehicle ISOFIX Positions		
			Frt Passenger	Rear Centre	Rear Out Board
CARRYCOT	F (1)	ISO/L1	X	X	X
	G (1)	ISO/L2	X	X	X
GROUP 0 UP TO 10KG	E (2)	ISO/R1	X	X	IL
GROUP 0+ UP TO 13KG	E (2)	ISO/R1	X	X	IL
	D (2)	ISO/R2	X	X	IL
	C (2)	ISO/R3	X	X	IL
GROUP I 9 TO 18KG	D (2)	ISO/R2	X	X	IL
	C (2)	ISO/R3	X	X	IL
	B (3)	ISO/F2	X	X	IUF/IL
	B1 (3)	ISO/F2X	X	X	IUF/IL
	A (3)	ISO/F3	X	X	IUF/IL

NOTE: Key of letters be inserted in the above table

IUF: Suitable for ISOFIX forward child restraints systems of universal category approved for use in this mass group.

IL: Suitable for particular ISOFIX child restraint systems (CRS) given in attached list. These ISOFIX CRS are those of the "specific vehicle", "restricted" or "semi-universal" categories.

X: ISOFIX position not suitable ISOFIX child restraint systems in this mass group and/or this size class.

- (1) Some child seats are installed transversely and occupy two seats. Make sure that the feet of child are facing the door.
- (2) Slide the front seat forward all the way to install the rear-facing child restraint. Then, slide the front seat back as directed in the manual provided with the child restraint.
- (3) When using a forward-facing child restraint, do not slide the front seat backwards more than halfway for child's safety. In addition, do not tilt the front seat backrest backwards too far (max. 25°) and raise it as high as possible.

Table of Vehicle Handbook Information for Installation in Various Seating Positions on i-Size Child Restraint Systems

Seating Posion	i-Size Child Restraint Systems
Front Passenger Outboard	X
Rear Outboard Left	i-U
Rear Outboard Right	i-U
Rear Center	X

Key of letters to be inserted in the above table:

i-U: Suitable for i-Size "universal" Child Restraint Systems forward and rearward facing. (valid position for forward facing and rearward facing child restrant systems approved under ECE R129)

i-UF: Suitable for forward-facing i-Size "universal" Child Restraint Systems only.

X: Seating position not suitable for i-Size "universal" Child Restraint Systems.(invalid position for child restrant systems approved under ECE R129)

List of suitable universal Child Restraint Systems (CRS)

Please read carefully the installation manual of your child restraint

Mass group	Child Restraint	Features
0	< 10 kg	-
0+	< 13 kg	Maxi Cosi CabrioFix
I	9 to 18 kg	Römer King II LS
II	15 to 25 kg	Römer KidFIX II XP SICT
III	22 to 36 kg	Römer KidFIX II XP SICT
		Peg-Perego Viaggio 2~3 shuttle

List of suitable ISOFIX Child Restraint Systems (CRS)

Please read carefully the installation manual of your child restraint

Mass group	Child Restraint	Features
0	< 10 kg	-
0+	< 13 kg	Maxi Cosi CabrioFix & FamilyFix
I	9 to 18 kg	Römer Duo+
II	15 to 25 kg	Römer KidFIX II XP SICT
III	22 to 36 kg	Römer KidFIX II XP SICT
		Peg-Perego Viaggio 2~3 shuttle

List of suitable i-Size Child Restraint Systems (CRS)

Please read carefully the installation manual of your child restraint

Mass group	Child Restraint	Features
67 cm - 105 cm ≤ 18.5 kg	Maxi Cosi 2way Pearl & 2wayFix	ISOFIX & Support Leg Rearward facing
> 15 months 105 cm ≤ 18.5 kg		ISOFIX & Support Leg Forward facing
100 cm - 135 cm	Besafe iZi Flex FIX i-size	ISOFIX & Support Leg (without side bumpers)

Installation of crs secured by the seatbelt

Front-facing Child Seat



Secure the child restraint with a seat belt as shown in the figure.

Caution

- When installing a child restraint system, follow the instructions provided by the manufacturer.

Warning

Do not use the car seat unless the followings are met.
The child seat may not perform as intended, which may result in a serious injury.

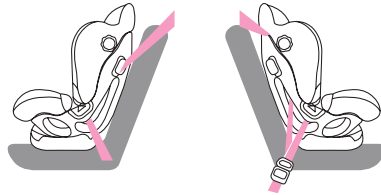

- Make sure that the buckle of the seat belt is securely engaged.
- Make sure that the seat belt is not loose or twisted.
- Make sure that the base does not move due to excessive play in all directions.
- You can't adjust the angle of the backrest with the child seat installed. If you're trying to do so, the seat belt will be slack, which incurs danger. Always adjust the angle of the backrest before installing the child seat.

Rear-facing Child Seat

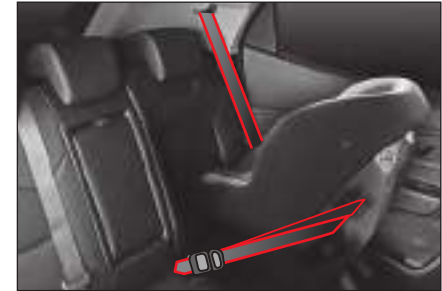

Secure the child restraint with a seat belt as shown in the figure.

Caution

- Never install a rear facing child restraint on the front seat without ensuring that the front airbag is deactivated. KG Mobility Corporation recommends that a child restraint to be installed on the rear seat.

When installing a child restraint, adjust the seat back angle as desired.

Warning

Do not use the child seat unless the followings are met.

The child seat may not perform as intended, which may result in a serious injury.

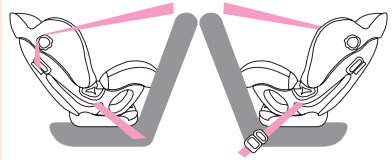

- **Make sure that the buckle of the seat belt is securely engaged.**
- **Make sure that the seat belt is not loose or twisted.**
- **Check if the angle of the backrest is set to 4 stage.**
- **Make sure that the base does not move due to excessive play in all directions.**
- **Make sure that the seat belt is routed through the rear-facing belt path and buckled up.**

Securing a child restraint system with “ISOFIX/i-Size” system and “Tether Anchorage” system*

ISOFIX/i-Size system is a standardised method of fitting child seats that eliminates the need to use the standard adult seatbelt to secure the seat in the vehicle.

This enables a much more secure and positive location with the added benefit of easier and quicker installation. An ISOFIX/i-Size-seat can only be installed if it has approval in accordance with the requirements of ECE R44 or ECE R129.

Locations of ISOFIX/i-Size Lower Anchors and Top Tether

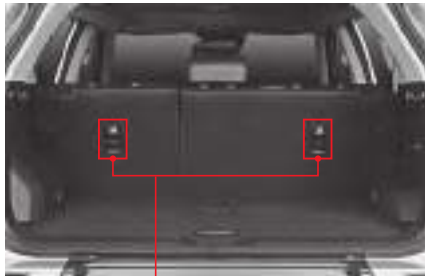

- 1 Two ISOFIX/i-Size lower anchors are installed at the bottom of the seatback at each outboard seat as shown in the figure.
- 2 The ISOFIX/i-Size lower anchors can be identified by the symbol attached on the top surface.



- 3 Two (for EURO countries) or three (Australia) ISOFIX/i-Size top tethers are installed at the upper side of seatback.

How to use ISOFIX/i-Size Lower Anchor

The ISOFIX/i-Size lower anchor is exposed when you widen the space between seatback and cushion.



- 1 Now, you can see the ISOFIX/i-Size lower anchors.

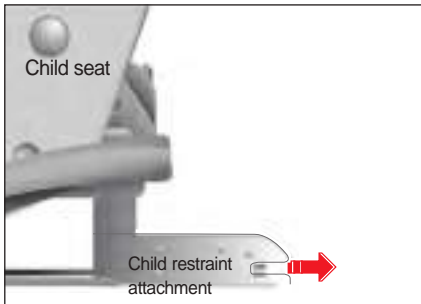

- 2 Insert the child restraint attachments into the ISOFIX/i-Size lower anchors until it clicks.
- 3 Adjust the seatback angle as desired.

Warning

- When using the ISOFIX/i-Size lower anchor, make sure that no interference are around the bar and the seat belt is not stuck.
- Rock the child restraint to check if it is securely installed. Refer to instructions provided by the manufacturer of the child restraint.
- Do not install the child restraint if it hinders the operations of front seat.

How to use Top Tether

- 1 Adjust the seatback angle as desired.



- 2 Connect the top tether connector in child restraint to the top tether on the seatback of the second row seat.
- 3 Securely tighten the child restraint by adjusting the webbing of top tether connector.

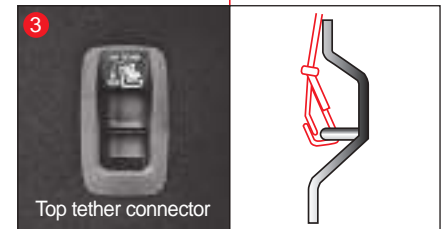
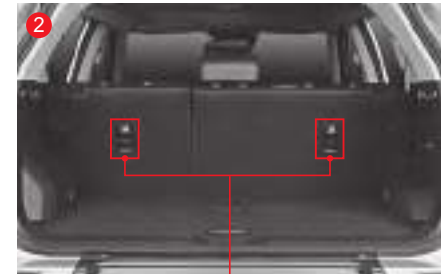

Warning For Child Restraint

- **Use only the officially approved child restraint.**
KG Mobility is not responsible for the personal injury and property damage due to the defect of child restraint.
- **These seats are subject to the ECE R44 or ECE R129 standard.**
- **Use only the child restraint with proper type and size for your baby.**
- **Use only the child restraint at proper location.**
- **Child restraint has 5 categories based on the weight as below according to ECE R44.:**
GROUP 0: 0 ~ 10KG
GROUP 0+: 0 ~ 13KG
GROUP I: 9 ~ 18KG
GROUP II: 15 ~ 25KG
GROUP III: 22 ~ 36KG
- **Group 0 & 0+**
Rear facing child restraint fitted on the rear seat
- **Group I**
Rear facing or forward facing child restraint fitted on the rear seat
- **Group II & III**
Booster seat fitted on the rear seat with seat belt fastened
Always follow the installation and use instructions provided by the manufacturer of the booster seat.

- **i-Size: child seats with i-Size approval must meet the requirements prescribed in the ECE R129 standard in relation to installation and safety. Child seat manufacturers can tell you which seats have i-Size approval for this vehicle.**



Caution

- **Top tether is the supplemental device to secure the child restraint system after engaging it by the lower latches. Therefore, do not secure the child restraint system only with the top tether. The increased load may cause the hooks or anchors to break, causing serious injury or death.**
- **If a child restraint is not properly secured to the vehicle and a child is not properly restrained in the child restraint, the child could be seriously injured or killed in a collision. Always follow the instructions provided by the manufacturer for installation.**
- **Make sure the latches of the child restraint system are latched to the lower latches. In this case, you can hear the “click” sound.**
- **The child restraint seat strap may not work properly if attached somewhere other than the correct top tether.**
- **Make sure that the child restraint system is firmly secured by rocking it in different directions.**
- **Incorrectly installed child restraint system may cause an unexpected personal injury.**

Air bag*

The air bag is an ancillary safety unit that inflates instantaneously in the event of a vehicle collision, protecting an occupant from the impact.

The air bag system is composed of the air bag crash sensor, air bag control module and air bag.

The air bag operates according to various factors including the strength and direction of a vehicle collision, strength of a colliding object, vehicle speed and the condition of the occupant.

Warning

- The air bag is an auxiliary unit that supplements the protection function of the seat belt and it cannot replace the seat belt. The seat belt should be fastened during driving.
- The air bag includes electric sensors and control modules and it only operates when the ignition switch is in the On position or the vehicle is running.
- The air bag is installed on the part where "AIRBAG" is displayed. Do not apply an impact to, place an article on or attach an accessory to the part where the air bag is installed. Doing so may cause a serious injury when the air bag inflates.
- When 10 years have passed after the air bag is installed, make sure to have the air bag checked at a KG Mobility Corporation Authorized Service Center even if there is no abnormality in the air bag system visually.

Air bag warning label

The air bag warning label displaying the risk of secondary damages in case the air bag inflates and safety information is attached to the passenger side sun visor. Read and familiarize yourself with the safety information before driving.



Warning

- The air bag is a unit that explodes a type of gunpowder in the unit and inflates the air bag instantaneously to protect the occupant. Therefore, noise, glare and smoke occur due to the explosion of gunpowder when the air bag inflates.
- The occupant may get burned when the air bag inflates. In some cases, the occupant may suffer injuries such as a bruise, bone fracture, abrasion and facial blows due to the inflated air bag and secondary damages such as broken glass.

Air bag warning lamp

The air bag warning lamp turns on when the ignition switch is turned On, and it turns off when there is no abnormality in the air bag system.

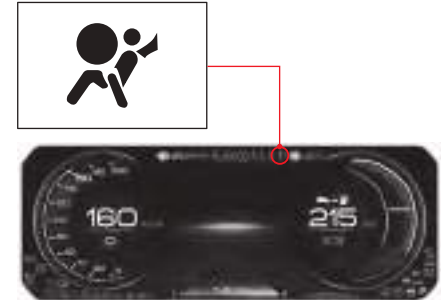

Warning

- If the air bag warning lamp stays on continuously, it indicates that there is abnormality in the air bag or the seat belt pretensioner system. Have your vehicle checked and serviced at a KG Mobility Corporation Authorized Service Center immediately.

Air bag crash sensor and air bag control module

The vehicle is equipped with sensors that can detect a collision and a module that controls the air bag operation.



- 1 Air bag control module
- 2 Front impact sensor (G-sensor type)
- 3 Side impact sensor (pressure sensor type)
- 4 Side impact sensor (G-sensor type)

Configuration of air bag

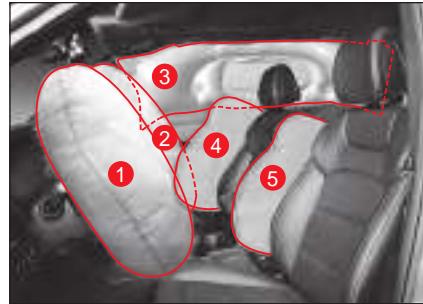

- 1 Driver air bag
- 2 Front passenger air bag
- 3 Curtain air bag
- 4 Front seat side air bag
- 5 Front center side air bag
- 6 Driver knee air bag

Passenger Air Bag ON/OFF Switch*



The front passenger air bag is disabled (not inflatable) when placing the passenger air bag ON/OFF switch to "OFF" position. This switch is located on the right side of the instrument panel, and you can see it when opening the front passenger door. Press and turn this switch to operate.

"OFF" position: disabled (not inflatable)

"ON" position: enabled (inflatable)

Driver air bag

The driver air bag protects the driver's head in the event of a front collision.

The driver air bag is installed in the center of the steering wheel.



Warning

- The driver should sit as far as possible from the steering wheel within the range that it does not hinder the driver from controlling the vehicle. If the driver sits too close to the steering wheel, a fatal injury may occur when the air bag inflates.
- Do not place any object on or attach an accessory or a sticker to the air bag cover (steering wheel cover). Doing so may hinder the air bag from operating normally and increase a risk of injury when the air bag inflates.

Driver knee air bag

The driver knee air bag operates along with the driver air bag at the same time in the event of a front collision, protecting the driver's knees.

The driver knee air bag is installed in the dashboard under the steering wheel.



Front passenger air bag

The front passenger air bag protects the front passenger's head in the event of a front collision.

The front passenger air bag is installed inside of the dashboard in front of the front passenger seat.

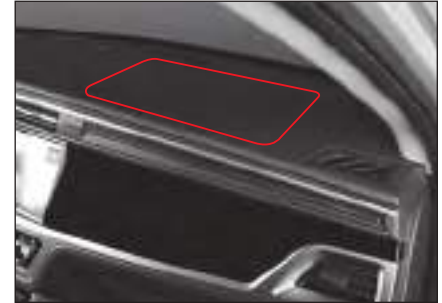

Warning

- Sit as far as possible from the dashboard where the front passenger air bag is installed. If the front passenger sits too close to the dashboard, a fatal injury may occur when the air bag inflates.

Notice

- The front passenger air bag operates along with the driver air bag at the same time.

Front seat side air bag

The front seat side air bag protects the side of the front seat occupant in the event of a side collision that meets the condition for inflating the air bag.

The front seat side air bag is mounted in the side of the driver seat backrest and the front passenger seat backrest.



Warning

- Do not hang clothes or accessories or use seat covers on the seats where the side air bag is mounted.
- Do not apply impact to the area where the collision detection sensor for the side air bag (front seat backrest) is installed. Doing so may cause the side air bag to malfunction.

Front center side air bag*

The front seat center side airbag unfolds between the passenger and the driver in the event of a side collision to prevent the passengers from being injured by a physical collision between them.



Warning

- Do not use seat covers or hang clothes/ accessories on the seats with front seat center side air bag.

Curtain air bag

The curtain air bag protects the head of the front seat occupants and the rear seat occupants in the event of a side collision that meets the condition for inflating the air bag.

The curtain air bag is mounted on the roof at the top of the front and rear doors on both sides.



Warning

- Do not apply impact to the curtain air bag crash sensor (bottompart of the B pillar). Doing so may cause the curtain air bag to malfunction.
- Do not slam the door. Doing so may cause the air bag to malfunction.

Notice

- The side air bags and the curtain air bags operate at the same time in the event of a side collision, but the left and right side air bags and curtain air bags operate separately.

Cases where the air bag does not inflate

The air bag does not inflate in all collision accidents. The air bag may not inflate, in any of the following cases:

In the event of a slight collision

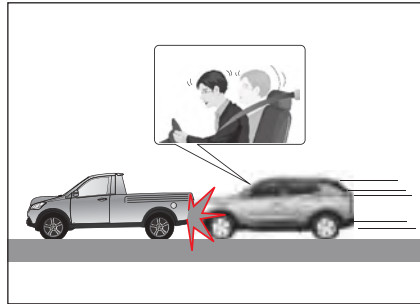

The air bag may not inflate in the event of a slight collision that the collision detection sensor cannot detect or the strength of collision is weak.

In such case, the seat belt can provide enough protection and the air bag operation may instead give secondary damages to the occupant such as a burn or an injury.

In the event of a rear end collision

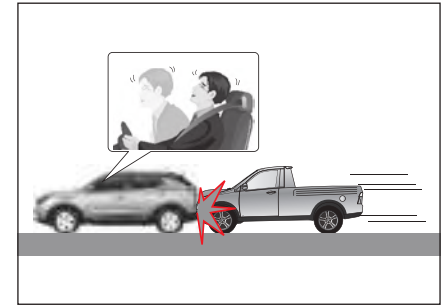

In the event of a rear end collision by another vehicle, the body of the occupants move backwards, so the air bag cannot provide enough protection even if it inflates. In such case, the air bag may not inflate.

In the event of a side collision



In the event of a side collision, the occupants cannot be protected by the front air bags, so the front air bags may not inflate. However, the curtain air bags and the side air bags operate depending on the degree of impact in the event of a side collision, protecting the front seat occupants.

In the event of a diagonal collision

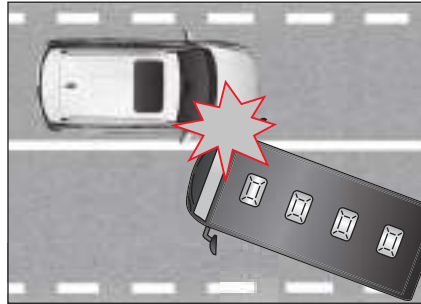

Since the impact of a collision in the diagonal direction is weaker than the impact of a collision in the front or side direction, the air bag may not inflate.

In the event of a collision with a narrow object



In the event of a collision with a narrow object such as a street light, utility pole or tree, the degree of impact applied to the sensor may not be enough, so the air bag may not inflate.

In case the vehicle moves beneath another vehicle

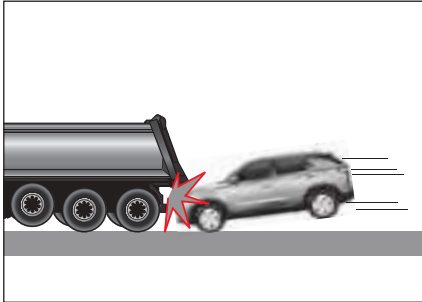

Generally, most drivers apply a sudden brake when an accident occurs, so the front part of the vehicle becomes lower. Therefore, the vehicle often moves beneath the opposing vehicle in the event of an accident against a tall vehicle such as a bus or a truck. In such case, the air bag may not inflate.

In the event of a rollover accident



If the vehicle turns over or rolls over, the occupant cannot be protected fully by the air bag alone. In such case, the air bag may not inflate. However, the curtain air bag or the side air bag may inflate according to the degree of impact applied to the side when the vehicle turns over.

Secondary injury due to air bag deployment



If the air bag control module detects the impact during an accident, it transmits the signal to deploy the air bag. This signal triggers the explosion of the powder, which is included in the air bag module, and the air bag deploys in a very short time to protect the occupants. When the air bag inflates, there will be heavy noise, glare and smoke. You could suffer secondary injuries caused by inflated air bag such as an abrasion, a bruise, a burn or injury by broken glasses.

Other cases

Cases where the driver/front passenger air bags do not inflate

- When the air bag warning lamp is on
- When an impact is applied to the top of the hood by a falling rock, etc.
- When the vehicle falls into a drainage ditch or a puddle

Cases where the side air bags or curtain air bags do not inflate

- When the air bag warning lamp is on
- In case of a front or rear collision
- When the vehicle rolls over or turns over in the side direction with a moderate degree of impact

Warnings for the air bag

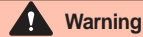

Seating an infant or a small child

- Do not let an infant or a small child sit in the front passenger seat or ride with an infant or a small child in your arms. The infant or the small child and you may get seriously injured or killed when the air bag inflates.
- Do not install a child restraint for an infant or a small child in the front passenger seat. If the air bag inflates, the infant or the small child may get seriously injured or killed due to the impact.
- When installing the child restraint for an infant or a small child in the rear seat of a vehicle where the curtain air bag is installed, install it as far as possible from the door. Failure to do so may cause serious injury or death of an infant or a small child when the curtain air bag inflates.

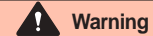

Driving and riding position

- Only hold the rim of the steering wheel when driving. Doing so ensures that the air bag inflates fully when it operates.
- Do not lean against the steering wheel or maintain your arms in an “X” shape. You may get seriously injured when there is a problem in the air bag operation or the air bag inflates.
- Do not drive while leaning forward or come too close to the steering wheel. You may get hit by the air bag and seriously injured on your head and neck or even killed before it inflates fully.
- If you wear the seat belt in an unstable position or while leaning to one side, the air bag cannot provide enough protection. You may even get seriously injured by the air bag.
- Do not place your feet or hands on the dashboard. You may get seriously injured when the air bag inflates.
- Do not lean against the door or stick your arm out of the window. You may get seriously injured when the curtain air bag inflates.



Warning

Handling the air bag

- Do not apply impact to air bag-related devices including the steering wheel, the part where the air bag is installed, wires and the seat belt pretensioner system. You may get seriously injured when the air bag inflates suddenly.
- Do not apply impact to the seat backrest where the side air bag is installed. Doing so may cause the side air bag to malfunction.
- Do not slam the door when closing the door. Doing so may cause the curtain air bag or the front air bag to malfunction.
- Do not place any object between the air bag and the occupant. Doing so may hinder the operation of the air bag and you may get injured by such an object when the air bag inflates.
- After the air bag and the seat belt pretensioner operate, their relevant components become very hot. Never touch such components until they have cooled down.



Warning

Operation of the air bag

- The air bag is a unit that protects the life of a passenger from a sudden accident, and it inflates at high speed by hot gas. The occupant may suffer injuries such as a burn, abrasion or bruise according to the circumstances at the time when the air bag inflates.
- A loud noise, dust, smoke or gas that occurs when the air bag or the seat belt pretensioner operates is normal.
- Gas generated when the air bag or the seat belt pretensioner operates is nontoxic, but if your skin, eyes or nose becomes irritated, wash with clean water. If the symptom persists, consult your doctor.
- Caution should be taken that the windshield or window glasses may be broken due to an impact from the operation of the front seat air bag or curtain air bag.



Warning

Do not modify the air bag or change the structure

- Do not modify or change the structure of any air bag-related devices including the steering wheel, the part where the air bag is installed or the wires. Do not check an air bag-related circuit with a tester. Doing so may cause the air bag system to malfunction or break down, resulting in personal injury and property damage.
- Do not replace the steering wheel with a product which is not a KG Mobility Corporation genuine part. Doing so may cause the air bag in the steering wheel not to operate normally.

Tire pressure monitoring system (TPMS)

The tire pressure monitoring system (TPMS) is an auxiliary safety unit that detects if the tire pressure is abnormally high or low and informs such fact to the driver, preventing an accident that may occur due to the tire pressure.

- The global warning light (⚠) comes on if the tire pressure is abnormal.
- Also, if there is abnormality in the tire pressure monitoring system (including the sensor), the global warning light (⚠) blinks and stays on.

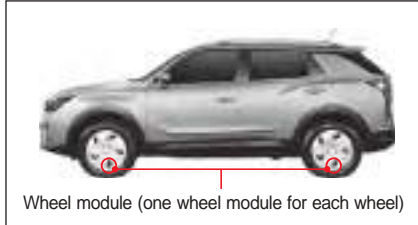

The electronic control unit of the TPMS receives various data including the tire pressure and temperature from the wheel module mounted on each wheel and displays such data on the instrument cluster.

- Proper tire pressure: 36 psi, 2.48 bar
- The proper tire pressure is the value measured at room temperature (20 °C) in the condition of an empty vehicle when the tires have been cooled properly.

Notice

- If the vehicle is driven at a speed of 30 km/h or faster after the vehicle is started, the tire pressure is detected within 5 minutes although it might be slightly different depending on the system status. If the tire pressure is not sensed, “-” will be displayed.

⚠ Caution

- The tire pressure displayed on the display of the instrument cluster can be changed by various environmental factors including the driving status of the vehicle, number of occupants in the vehicle and the status of air injection into the tires.
- When air is injected into a tire, airs with different temperature are mixed, so the tire pressure may be changed until a temperature balance is reached.

2

Checking the tire pressure

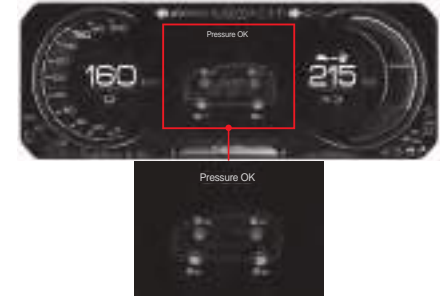

By selecting TPMS status from the main menu (1) of the instrument cluster, you can check all tire pressures from the display (2) of the instrument cluster.

If the tire pressure or the TPMS is abnormal

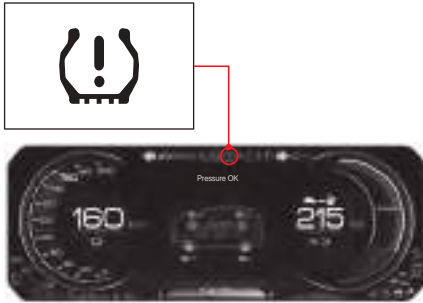

If the tire pressure or the tire pressure monitoring system is abnormal, the global warning light blinks or comes on.

- Abnormal tire pressure (low/flat): The global warning light stays on.
- Abnormal tire pressure monitoring system (including the sensor): The global warning light blinks for approximately 70 seconds and stays on.





Warning



- If the global warning light comes on in the instrument cluster, the tire pressure is insufficient, excessive or uneven. Make sure to park your vehicle at a safe place and check the tire pressure.
- If the global warning light stays on after checking the tire pressures, starting the vehicle and driving the vehicle for more than 10 minutes at a speed over 30 km/h, have your vehicle checked and serviced at a KG Mobility Corporation Authorized Service Center.
- A sudden tire damage due to an external factor such as a nail or a road debris, etc. may not be detected immediately. If the vehicle becomes unstable while driving, slow down, move the vehicle to a safe place and check the vehicle.
- Do not modify or remodel your vehicle in a way that hinders the operation of the TPMS.
- For safety, always use genuine wheels equipped with the tire pressure monitoring sensor.

Caution

- Adjust the tire pressure when the tires are cold (no driving for 2 or 3 hours).
- Even if the tire pressure has been adjusted to a proper tire pressure, the global warning light (⚠) may come on due to a difference in the internal tire temperature and air temperature. This is the phenomenon that the tire pressure drops in proportion to the temperature and this does not indicate that the TPMS is abnormal.
- If you need to drive while the ambient temperature rises or drops rapidly, check and adjust your tire pressure to the prescribed inflation pressure in advance before driving.
- For safe driving, check your tire pressure regularly without simply depending on the TPMS.

Display of the TPMS status on the instrument cluster

Item		Operating condition		
Tire pressure OK		<ul style="list-style-type: none"> It is displayed when the tire pressure is normal. 		
Low pressure		<table border="1"> <tr> <td data-bbox="609 475 764 562">Notice</td> <td data-bbox="764 475 1511 562"> <ul style="list-style-type: none"> In order to detect low tire pressure, each wheel must be correctly equipped with a TPMS wheel module. Otherwise, the warning lamp may be illuminated. </td> </tr> </table>	Notice	<ul style="list-style-type: none"> In order to detect low tire pressure, each wheel must be correctly equipped with a TPMS wheel module. Otherwise, the warning lamp may be illuminated.
	Notice	<ul style="list-style-type: none"> In order to detect low tire pressure, each wheel must be correctly equipped with a TPMS wheel module. Otherwise, the warning lamp may be illuminated. 		
	<ul style="list-style-type: none"> It is displayed when the tire pressure is too low and that it needs to be checked. The pressure figure of the relevant tire is inversely shaded and the global warning light comes on. 			
Check tires		<ul style="list-style-type: none"> It is displayed when the tire pressure is low to the extent that it should be checked. 		

Item		Operating condition
Flat tire		<ul style="list-style-type: none"> It is displayed when the tire pressure decreases rapidly or a tire is flat. The pressure figure of the relevant tire is inversely shaded and the global warning light comes on.
High pressure		<ul style="list-style-type: none"> It is displayed when the tire pressure is too high. The pressure figure of the relevant tire is inversely shaded and blinks.
Pressure imbalance		<ul style="list-style-type: none"> If a difference between left and right tire pressures is 5 psi or more, the pressure figure of the relevant tire is inversely shaded and blinks.
Notice	<p>If a certain tire pressure is shown as “--” while the other tire pressures are shown normally, the TPMS wheel module of the relevant tire may be abnormal. Have your vehicle checked and serviced at a KG Mobility Corporation Authorized Service Center immediately.</p>	

When low tire pressure is detected

When a tire with significantly low pressure is detected, the global warning light () comes on and the position of the relevant tire with low pressure is indicated on the instrument cluster.

In such case, slow down, bring your vehicle to a KG Mobility Corporation Authorized Service Center and have your vehicle checked and serviced.



Caution

- If you drive the vehicle continuously with a low tire pressure, the life of the tires, vehicle operating force, brake force and vehicle fuel efficiency may decrease.
 - If you cannot bring your vehicle to a KG Mobility Corporation Authorized Service Center, add air to the tire using the service kit for tire repair.
-  Refer to "Inflating a tire" (p.5-12)

When you have rotated the tires

When you have rotated the tires, the TPMS resets the position of each tire.

If the vehicle is driven at a speed of 30 km/h or faster, typically the system completes the reset within 5 minutes although it might be slightly different depending on the system status.

 Refer to "Rotating the tire positions" (p.6-29)



Warning

- If you replace a tire where sealant has been injected for repairing the tire, be sure to have the exterior of the TPMS sensor and the TPMS checked for normal operation at a KG Mobility Corporation Authorized Service Center.



Caution

- If you rotated the tires or replaced a wheel module including the tire pressure detection sensor, the tire position may not be recognized correctly at the beginning of driving so that the previous tire pressure may be displayed or the global warning light () may turn on. This is a temporary state which is not a failure.
- The time taken for resetting the tire position may vary depending on the driving condition of the vehicle.

Cautions for the TPMS



Caution

- If a wheel without a wheel module (tire pressure detection sensor) is installed to the vehicle, the global warning light turns on and the TPMS does not operate.
- Do not rely too much on the TPMS and be sure to check the tire pressure status before driving the vehicle.
- The TPMS operates in a way that it communicates with the wheel module by wireless. Therefore, if an electronic device such as a mobile speed camera detector that can create radio interference is installed to the vehicle, the TPMS may not operate normally.
- In an area with a strong electromagnetic field (police stations, government offices, broadcasting stations, military facilities, transmitting towers, etc.), the TPMS may fail and the global warning light (⚠) may turn on.
- If any foreign object is caught in the transmitter attached to the tire wheels while driving on a muddy or snowy road, hindering the communication with the receiver of the vehicle, the radio interference occurs due to strong external waves or a metal object is located near the TPMS, the tire pressure may be displayed with a time delay or may not be displayed normally.



Caution

- When you drive the vehicle with snow chains installed, the snow chains may hinder the communication between the wheel module and the antenna so that the TPMS may not operate normally. However, this does not impair the operation of the vehicle.
- When air is injected into a tire, the tire pressure displayed on the air injection device may be different from the tire pressure displayed on the TPMS. This difference is caused by factors including the driving status of the vehicle, number of occupants in the vehicle and the status of air injection into the tire and this does not indicate the failure of the TPMS.
- Be careful not to damage the wheel module when the tires are replaced. If the wheel module receives an impact or is damaged when the tires are replaced, the tire pressure detection function does not operate.
- If you have your tires replaced at a tire shop other than a KG Mobility Corporation Authorized Service Center, be sure to inform that the TPMS has been fitted to the tires.
- The life of the battery in the tire pressure detection sensor (wheel module) may be reduced if abnormalities such as checking tire pressure, low pressure, high pressure and pressure imbalance occur frequently.

Anti-theft and warning system

Immobilizer system*

The immobilizer system is a vehicle anti-theft system that prevents it from starting the vehicle unless a permitted key is used.

The vehicle can only be started when authentication is done by comparing the password of the transponder built into the smart key with password of the electric vehicle control unit.

Caution

- The immobilizer system cannot be removed from the vehicle under any circumstance. If you arbitrarily remove or damage the immobilizer system, you cannot start the vehicle. Never remove, damage or modify the immobilizer system.
- The immobilizer system should be repaired only by a licensed technician at a KG Mobility Corporation Authorized Service Center.
- When the code of the transponder is deleted or an additional key is registered, observe the process in person.
- Do not install a metallic accessory near the smart key. Such accessory changes the signal delivered to the ignition switch, preventing it from starting the vehicle.
- Do not drop the smart key or apply impact to it. Doing so may damage the transponder.
- Do not modify the vehicle arbitrarily to install a remote starting device. Doing so may cause a problem in starting the vehicle or a fatal accident.

Immobilizer/smart key warning light

If the immobilizer or the smart key system is abnormal, the immobilizer/smart key warning light will blink.

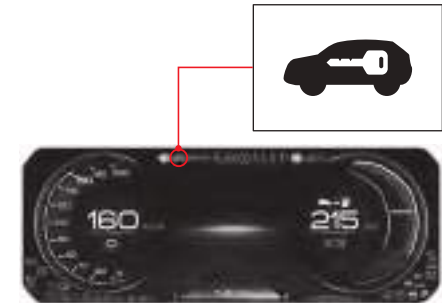

2

Notice

- The communication time between the transponder and the vehicle control unit varies depending on the case. If the communication time is short, the warning lamp may not be lit.

If the vehicle does not start

In the event of the communication error between the transponder and the vehicle control unit due to a system internal fault or external communication obstacle, the vehicle will not start.

In such case, the immobilizer warning light will blink.

You may not be able to start the vehicle in a vehicle with the immobilizer system, in any of the following cases:

- When two or more smart keys come into contact with each other are used
- When the smart keys is used near a device that sends or receives electromagnetic fields or waves
- When the smart keys is used near electric or electronic devices such as lighting equipment, security keys or security cards
- When the smart keys is used near a key chain, a magnet, a metallic object or a battery



Caution

- **You may not be able to start the vehicle due to an external factor (key chain, magnet, etc.) or early starting before the vehicle preheating time to cause communication failure with the immobilizer. In such case, eliminate the factor preventing it from starting the vehicle, place the smart key outside the operation range of the antenna for approximately 10 seconds or longer and start the vehicle again.**
- **If the immobilizer/smart key warning light blinks continuously and you still cannot start the vehicle after eliminating the external factor, have your vehicle checked and serviced at a KG Mobility Authorized Service Center.**

When the transponder is damaged

You can't start the vehicle with a key whose transponder is damaged. In such case, replace the smart key with a new one and register the relevant code on the vehicle control unit.

When you lose the key

When you lose your key, the transponder code of the lost key registered on the vehicle control unit should be deleted.

Have KG Mobility Authorized Service Center take measures for preventing vehicle theft by a lost key.

Theft deterrent system

The theft deterrent system is a device that prevents theft of the vehicle by activating the anti-theft alarm when the door, tailgate or hood is open in an armed mode.

Entering the theft monitoring mode

When the door lock button (including the door lock/unlock button on the exterior of the front doors) of the smart key is pressed with all doors, tailgate and hood closed, the system enters the theft monitoring mode.

- When the system enters the theft monitoring mode, the warning light blinkstwice and the warning buzzer sounds once.
- When the theft deterrent system is armed, the hazard flashers blink twice and the buzzer sound once.
- If approximately 30 seconds have passed without opening the door after unlocking the door using the smart key in the theft monitoring mode, all doors are locked again and the system enters theft monitoring mode.



Caution

- **If you insert the key into the door key hole and lock the doors, only the doors are locked but the theft deterrent system is not activated.**
- **The system enters the theft monitoring mode only when the ignition switch is on Off and all doors, tailgate and hood are closed completely.**
- **If the ignition switch is on Acc or On or the vehicle is being started, the system does not enter the theft monitoring mode.**

Activating the theft alarm

In the theft monitoring mode, the warning light and the warning buzzer operate at an interval of 1 second for 30 seconds in any of the following cases:

- When an attempt to open the door, tailgate or motor room hood without using the smart key is made
- When the key is inserted into the key hole to open the door
- When the door lock lever is placed in the unlock position forcibly

When the theft deterrent system is activated, the alarm stops in any of the following cases: However, the theft monitoring mode is maintained at this time.

- When the door lock button or door unlock button on the smart key is pressed
- When the door lock/unlock button on the exterior of the front door is pressed
- When the ignition switch is On
- Pressing "Lock" or "Unlock" button on the Smart key, pressing the "Lock/Unlock" button on the outside door handle, or turning the ignition switch to "ON" mode by pressing it.

Holding the theft alarm

The alarm does not sound and is on hold in any of the following cases:

- When the tailgate is opened by pressing the open tailgate button on the smart key
- When the tailgate is opened by pressing the open button inside the tailgate door handle with the smart key detected

Notice

- **An armed mode is maintained even if the tailgate is open in an anti-theft alarm hold state. When the tailgate is closed, it also returns to an armed mode.**

Canceling the theft monitoring mode

The theft monitoring mode is canceled when the door is switched to the Unlock position using the smart key (including the door lock/unlock button on the exterior of the front doors).

Notice

- **When the theft monitoring mode is canceled, the warning light blinks once and the warning buzzer sounds twice.**
- **All doors are locked again and the system enters theft monitoring mode, when approximately 30 seconds have passed without opening the door after unlocking the door using the smart key in the theft monitoring mode.**

3. Convenient Equipment

You can check information regarding devices that allow you to drive the vehicle conveniently and wisely and how to use such devices.

An explanation is provided for doors, seats, windows as well as various convenient equipment including the tailgate, various lights and lamps, mirrors, heater and air conditioner, AV/navigation, storage and cargo box.

Locking, unlocking and opening the door

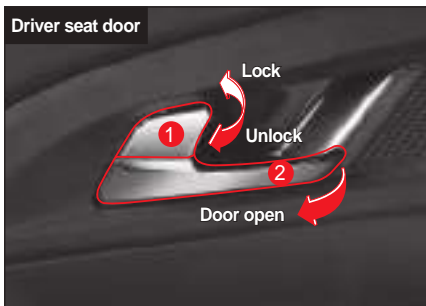

- 1 Door lock/unlock lever
- 2 Door open lever

Door lock/unlock lever

- When you push the driver seat door lock/unlock lever (1) in the lock direction, all doors and the tailgate become locked.
- When you pull the driver seat door lock/unlock lever (1) in the unlock direction, all doors and the tailgate are unlocked.

- When you push or pull the rear seat door lock/unlock lever (1), only the relevant door is locked or unlocked.

Caution

- You cannot lock the door using the door lock/unlock lever or the smart key when the door is opened even slightly.

Door open lever

- If you pull the door open lever (2) when the door is locked, the door is unlocked and opened.
- If you pull the door open lever (2) when the door is unlocked, the door is opened.

Warning

- Be careful not to pull the door open lever to open the door while driving. If the door is opened while driving, you may face a serious risk.

Door Lock/Unlock button

Each time the door Lock/Unlock button on the driver seat is pressed, the status of all doors and the tailgate is changed between locked and unlocked alternately.



Caution

- You cannot lock the door using the door Lock/Unlock button or the smart key when the door is opened even slightly.
- You cannot unlock the door with the driver door Lock/Unlock button in theft monitoring mode.



Warning

- Before driving the vehicle, lock all doors from the driver seat using the door lock/unlock lever. Be sure to drive the vehicle with all doors locked when a child is present in the vehicle. If the door is opened suddenly while driving, you may face a serious risk.
- Before you get out of the vehicle, check the rear and front sides of the vehicle first to see if there is a vehicle, motor cycle, bicycle or person passing by. In particular, opening the door without checking the rear side may lead to an accident.

Auto door lock function at the time of driving

When the vehicle speed exceeds the set speed, all doors and tailgate are automatically locked.

Notice

- You can set at **Vehicle setting** → **Door / Tailgate** → **Auto lock** under  (user settings) in the instrument cluster.

Auto door unlock function at the time of collision

When a collision accident occurs with all doors locked and the air bag is activated, all doors are unlocked automatically.



Warning

- If the vehicle body or a door has been deformed due to an impact from an accident, the auto door unlock function may not operate normally.

Child safety door lock

The child safety door lock is installed in order to prevent a child from opening the door in the vehicle when a child is present in the rear seats. The child safety door lock is provided at the inner side of the rear seat doors.



Locking/unlocking the door lock

When the child safety door lock is locked, the rear seat doors cannot be opened with the door open lever in the vehicle even if the rear seat doors are unlocked. In such case, the rear seat doors can be opened only from the outside of the vehicle.

Locking the child safety door lock

Place the child safety door lock lever in the lock position by turning it counterclockwise.



Unlocking the child safety door lock

Place the child safety door lock lever in the unlock position by turning it clockwise.



Warning

- When a child is present in the vehicle, place the child safety door lock lever in the lock position to prevent the child from opening the door in the vehicle.

Seat & adjustment switch / button / lever

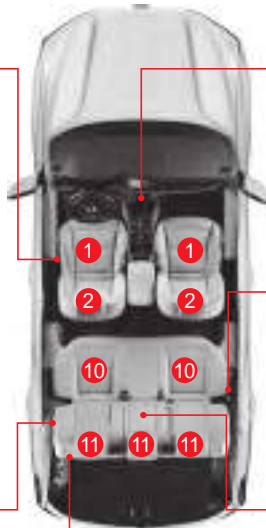

Front seat

- 1 Front seat
- 2 Sliding headrest
- 3 Driver seat Heating and Ventilation button
- 4 Front passenger seat Heating and Ventilation button
- 5 Backrest angle control lever
- 6 Seat cushion angle control lever
- 7 Seat height control lever
- 8 Seat front and rear position control lever
- 9 Lumbar support control button (driver seat)

Rear seat

- 10 Rear seat (6:4 split type)
- 11 Headrest
- 12 Rear seat warmer button
- 13 Rear armrest (cup holder)
- 14 Rear seat webbing guide
- 15 Seatback reclining adjustment lever (folding)

Front seat

Adjusting the headrest

Adjusting the front and rear angles

- Push the rear section of the headrest (1) in the arrow direction. The angle of the headrest can be adjusted in 3 levels.
- To return the headrest to its original position, push it to the end in the arrow direction again and release it.

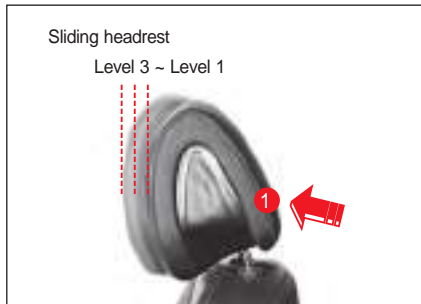

Adjusting the height

- To raise the headrest, hold and pull the headrest up.
- To lower the headrest, push the headrest down with the Lock button (1) pressed in the arrow direction.

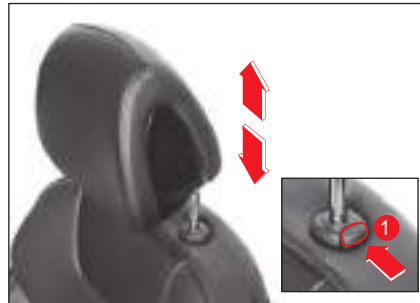

Notice

- Adjust the height of the headrest so that the center of the headrest is aligned with the occupant's eye level.
- It may not be possible to align the center of the headrest with the occupant's eye level due to the occupant's physical condition. In such case, align the height of the headrest with the highest position for a tall person and the lowest position for a short person.



Warning

- Do not drive the vehicle with the headrest lowered excessively. Doing so may cause fatal injury to body parts including head, neck or spine if an accident occurs.

Separation/installation

Separating the headrest

- 1 Recline the seat backrest to secure necessary space for separating the headrest safely.
- 2 With the Lock button (1) pressed in the arrow direction, separate the headrest by lifting it to the end.



- 3 Return the seat backrest to its original position.

Warning

- Never drive the vehicle with the headrest separated. Doing so may cause head, neck or spine injury.

Installing the headrest

- 1 Recline the seat backrest to secure necessary space for installing the headrest safely.
- 2 Insert the headrest into the groove of the seat backrest.
- 3 With the Lock button (1) pressed in the arrow direction, pull down the headrest to the desired position.
- 4 Return the seat backrest to its original position.

Adjusting the power seat*

Front and rear position adjustment (driver seat/front passenger seat)

Set the seat to the desired position by pulling or pushing the front and rear position adjustment lever.



Adjusting the height (driver seat/front passenger seat)

Set the desired height by raising or lowering the height adjustment lever.



Adjusting the cushion angle (driver seat/front passenger seat)

Set the desired angle by raising or lowering the cushion angle adjustment lever.



Adjusting the backrest angle (driver seat/front passenger seat)

Set the desired angle by pulling or pushing the backrest angle adjustment lever.



Warning

- Adjust the seat backrest to be upright as possible to maintain a comfortable position. Reclining the seat backrest excessively may cause the occupant to slip down below the seat belt in the event of a vehicle collision or sudden stopping. In such case, the occupant cannot be protected by the seat belt and the air bag, so the occupant may receive a serious injury or lose his/her life.

Adjusting the lumbar support (driver seat)

Set the lumbar support to the desired position by pressing the Lumbar support adjustment button.

- When you press the Forward/Backward adjustment button (1 / 2), the lumbar support is extended or retracted.
- When you press the Up/Down adjustment buttons (3 / 4), the lumbar support is raised or lowered.



Warning

- **Never adjust the seat while driving. If the seat moves suddenly, it may lead to a dangerous situation.**
- **After adjusting the seat, check that the seat is secured firmly.**
- **If there is an occupant in the rear seat, adjust the seat while paying attention to the safety of the occupant.**
- **If the power seat does not operate, drive the vehicle after checking and taking measures.**

Caution

- **Operating the power seat excessively may damage the electric devices. Use it only for adjusting the seat.**
- **Operating a number of seat adjustment switches at the same time may damage the motor. Be sure to finish using one function before using another function.**
- **The power seat operates even when the START/STOP switch is in the OFF status. However, caution should be taken that operating the power seat too frequently when the vehicle is turned off may cause depletion of the battery.**
- **If the height of the seat and headrest is high with the front seats pulled forward, be careful when folding the seat backrest forward. Failure to do so may cause the front seats, headrest, sun visor and other components to bump against each other, causing damage.**
- **If the power seat comes into contact with an object so that it does not move or operate, do not operate it forcibly. Operate it again after eliminating the cause. If there is abnormality, have your vehicle checked and serviced at a KG Mobility Corporation Authorized Service Center.**

Adjusting the seat manually

Front and rear position adjustment (driver seat/front passenger seat)

With the front and rear position adjustment lever pulled up, set the seat to the desired position by pulling or pushing the seat.



Adjusting the backrest angle (driver seat/ front passenger seat)

With the backrest angle control lever pulled up, move and set the backrest at the desired angle.



Adjusting the height (driver seat)

Set the desired height by raising or lowering the height adjustment lever.



Warning

- Adjust the seat backrest to be upright as possible to maintain a comfortable position. Reclining the seat backrest excessively may cause the occupant to slip down below the seat belt in the event of a vehicle collision or sudden stopping. In such case, the occupant cannot be protected by the seat belt and the air bag, so the occupant may receive a serious injury or lose his/her life.

Rear seat

Adjusting the height of the headrest

- To raise the headrest, hold and pull the headrest up.
- To lower the headrest, push the headrest down with the Lock button (1) pressed in the arrow direction.



Warning



- Adjust the height of the headrest so that the center of the headrest is aligned with the occupant's eye level.
- Do not drive the vehicle with the headrest lowered excessively. Doing so may cause fatal injury to body parts including head, neck or spine if an accident occurs.
- When there is no occupant in the rear seats, the rear head restraints should be kept as low as possible as since they may obscure the rear view.

Notice

- It may not be possible to align the center of the headrest with the occupant's eye level due to the occupant's physical condition. In such case, align the height of the headrest with the highest position for a tall person and the lowest position for a short person.

Seatback reclining adjustment

You can adjust the reclining in step 1 or 2 while pulling the seatback release lever (1) at the side of the rear seat backrest.

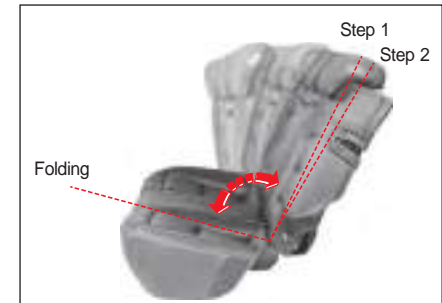

Caution

- When locking the rear seat backrest, make sure that the backrest unlock lever (1) clicks into the locked position so that the red label ("Unlocked" indicator) is not visible.



Rear seat backrest folding

- 1 Insert the seat belt into the webbing guide to prevent the seat belt from being damaged.
- 2 Position the headrest to its lowest level.

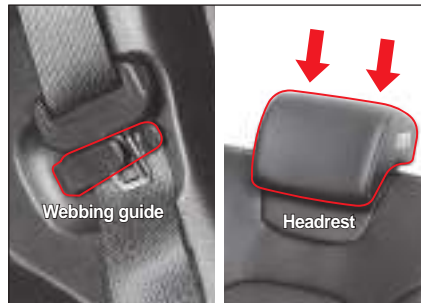

Caution

- When folding or unfolding the seat, it may hit and damage other components. To prevent such damage, lower the headrest of the seat to be folded to its lowest position and position the backrest of the seats in front of the folded seats.

- 3 Pull the rear seat backrest release lever (1).



- 4 Fold the backrest toward the front side of vehicle.



When returning the backrest to its original position, operate it in the reverse order.

Warning

- After returning the seat to its original position, gently rock the seat to make sure it is securely locked. If the seatback is not locked completely, it can be folded down unexpectedly.
- Be careful not to get your body parts to be caught in between the seats when folding the seat.
- Do not sit on the folded seat. You cannot be protected by the seat belt and other safety units and may be seriously injured in the event of an accident.
- When placing an article on top of the folded seat, secure the article firmly so that it won't move while driving. If the article moves, the driver and other passengers may get injured by the moving article. Also, a secondary accident may occur accordingly.

Caution

- After folding the backrest, press the top of the backrest to secure it firmly.

Seat ventilation and heating*

Front seat ventilation and heating*



- ① Front seat ventilation button
- ② Front seat heating button

Front seat ventilation

With the vehicle on, press the Front seat ventilation button (1).

The operation indicator (blue) turns on and the ventilation function is activated in the relevant seat.



- Each time the Ventilation button is pressed, the status of the ventilation function is changed in the order of OFF → Level 3 → Level 2 → Level 1 → OFF.
- When you press the Ventilation button for 1 second or longer while the ventilation function is operating, the function is deactivated.



Warning

- Do not insert your hand under the seat cushion while the seat ventilation function is operating. Doing so may cause your hand to be hit and injured by the spinning ventilation fan.

Notice

- The seat ventilation function is not the cooling seat that blows out cold air from the air conditioner.
- Since the seat ventilation function draws in air from inside the vehicle and performs the ventilation function, it is efficient to use it together with the air conditioner.
- When you turn off the vehicle while the seat ventilation function is operating, the ventilation function also turns off. The seat ventilation function won't turn on even if you start the vehicle again.

Front seat heating

With the vehicle on, press the Front seat heating button (2).

The operation indicator (yellow) turns on and the heating function is activated in the relevant seat.



- Each time the Heating button is pressed, the status of the heating function is changed in the order of OFF → Level 3 → Level 2 → Level 1 → OFF.
- When you press the Heating button for 1 second or longer while the heating function is operating, the function is deactivated.

Smart front seat heating control

This function controls the heating operation status automatically while assisting you to drive safely in a proper temperature condition.

- If the status of level 3 is maintained for approximately 30 minutes, the status of the heating function is changed to level 2 automatically.
- After the status is changed to level 2
 - When you activate the heating function in level 3 again within 5 minutes, the status of level 3 is maintained for approximately 8 minutes and then the status is changed to level 2 automatically.
 - When you activate the heating function in level 3 again after 5 minutes later, the status of level 3 is maintained for approximately 30 minutes and then the status is changed to level 2 automatically.
- If the status of level 2 is maintained for approximately 60 minutes, the status of the heating function is changed to level 1 automatically.

Warning

- Using seat heating excessively on the driver seat may cause drowsiness and interfere with safe driving.

Notice

- The seat heating function is designed to stop its operation when the temperature rises to a certain level and resume its operation when the temperature falls below a certain level.
- When you turn off the vehicle while the seat heating function is operating, the heating function also turns off. The seat heating function won't turn on even if you start the vehicle again.

Rear seat heating*

With the vehicle on, press the 1st row rear seat heating button.

The operation indicator (yellow) turns on and the heating function is activated in the relevant seat.



- Every time the heating button is pressed, the warmer is operated in the order of OFF → Level 2 → Level 1 → OFF.

Rear seat heating smart control

- This function automatically controls the operation status of the warmer and helps the driver to operate the vehicle safely at an appropriate temperature.
- After operating for about 30 minutes in level 2, it automatically changes to level 1.
- After being changed to level 1
 - If you operate the warmer at level 2 again within 5 minutes, it will stay the level for about 8 minutes and change to level 1 automatically.
 - If you operate the warmer at level 2 again after 5 minutes, it will stay the level for about 30 minutes and change to level 1 automatically.



Warning

- Caution should be taken that using the seat heating function excessively may cause a minor burn. Pay particular attention to an infant, a small child, an elderly, a disabled person, a person who took a drug that induces sleep, a drunk person, an over-worked person or a person with delicate skin.
- Caution should be taken that you may get a low temperature burn if your skin comes into contact with the heated seat for a long period of time.
- While using seat heating, do not place a blanket, cushion or sitting mat on the seat to prevent overheating.
- Using the seat heating excessively may cause overheating or fire. Be sure to check whether the seat heating is operating or not when getting in and out of the vehicle.
- If the seat becomes hotter continuously and out of control, turn off the seat heating function first. And, have your vehicle checked and serviced at a KG Mobility Corporation Authorized Service Center immediately.

Notice

- The seat heating function is designed to stop its operation when the temperature rises to a certain level and resume its operation when the temperature falls below a certain level.
- When you turn off the vehicle while the seat heating function is operating, the heating function also turns off. The seat heating function won't turn on even if you start the vehicle again.

Warnings and cautions related to the seats



Warning

- Be sure to finish adjusting the seat before driving.
- Never adjust the seat while driving. If the seat moves suddenly, it may lead to a dangerous situation.
- Adjust the seat backrest to be upright as possible to maintain a comfortable position. Reclining the seat backrest excessively may cause the occupant to slip down below the seat belt in the event of a vehicle collision or sudden stopping. In such case, the occupant cannot be protected by the seat belt and the air bag, so the occupant may receive a serious injury or lose his/her life.
- Never drive the vehicle with the headrest separated. Doing so may cause head, neck or spine injury.
- If the power seat does not operate, drive the vehicle after checking and taking measures.
- Caution should be taken that using the seat heating function excessively may cause a minor burn. Pay particular attention to an infant, a small child, an elderly, a disabled person, a person who took a drug that induces sleep, a drunk person, an over-worked person or a person with delicate skin.



Caution

- The power seat operates even when the START/STOP switch is in the OFF status. However, caution should be taken that operating the power seat too frequently when the vehicle is turned off may cause depletion of the battery.
- Operating a number of seat adjustment switches at the same time may damage the motor. Be sure to finish using one function before using another function.
- If the power seat comes into contact with an object so that it does not move or operate, do not operate it forcibly. Operate it again after eliminating the cause. If there is abnormality, have your vehicle checked and serviced at a KG Mobility Corporation Authorized Service Center.
- Do not place an object that can damage the seat upholstery on top of the seat.
- Do not use organic solvents such as thinner, benzene, alcohol or gasoline for cleaning the seat upholstery. Doing so may damage the surface of the upholstery.

Window (power window)*

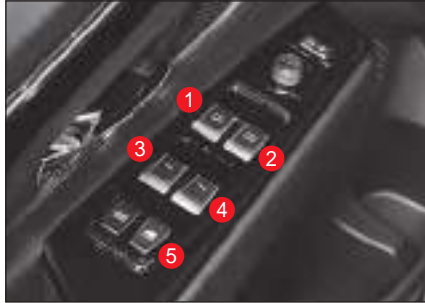

- 1 Driver seat window button (AUTO)
- 2 Front passenger seat window button (AUTO)
- 3 Rear left window button
- 4 Rear right window button
- 5 Rear seat window lock button

Notice

- To operate the window, the START/STOP switch should be in the ON status or the vehicle should be running.
- Even if the START/STOP switch is switched from the ON status to the ACC status or the OFF status, the Window button can be operated for approximately 30 seconds. However, the operation stops immediately when you open the front door.

Opening the driver seat/front passenger seat window

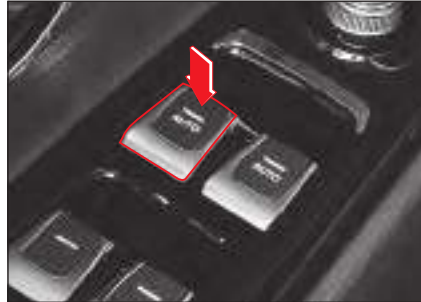

- Press the Driver seat/Front passenger seat window button slightly. The Window opens only while the button is being pressed.
- Press the Driver seat/Front passenger seat window button to the end and release it. The window opens to the end automatically (auto down).
- When you slightly press or pull the Driver seat/Front passenger seat window button up while the window is opening, the window stops.

Notice

- The vehicles with Auto Down have not fitted with the Auto Up and the window is closed only while the switch is being pulled.

Closing the driver seat/front passenger seat window

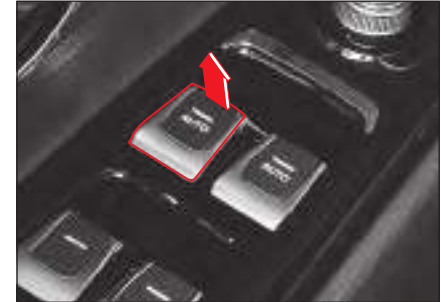

- Pull the Driver seat/Front passenger seat window button up slightly. The window closes only while you are pulling the button.
- Pull the Driver seat/Front passenger seat window button up to the end and release it. The window closes to the end automatically (auto up).
- When you press or slightly pull the Driver seat/Front passenger seat window button up while the window is closing, the window stops.

Driver seat window safety function

The driver seat window safety function controls the driver seat window equipped with the auto up function to move down slightly and stop without moving up from its position when it is recognized that a body part or an object is caught in it when the window is closing.



Notice

- The window safety function is activated on the driver seat & passenger seat window equipped with the auto up function.
- The safety function is not activated for some section of the window that is closed lastly.
- The window may get frozen during winter so that it may be misrecognized as a body part or an object being caught in it. In such case, close the window little by little by pulling the Window button slightly.
- When you do not release the Window button after pulling it up to the end, the window is closed to the end without stopping even if there is an obstacle in its moving path.

This function is intended to protect the driver from a crime such as robbery and injury.

Opening/closing the rear seat window

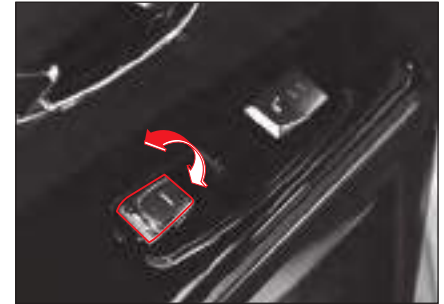

The window only works while pressing or pulling the rear seat window button.

Rear seat window lock function

This function locks the window so that it cannot be opened and closed from the rear seats.

Press the Rear seat window lock button.



Warning

- If a small child is seated in the rear seat, be sure to press the Rear seat window lock button to make the Window buttons inoperative. It can prevent an accident caused by the child's mischief.

What is wind buffeting?

Wind buffeting is the phenomenon when you feel pressure upon your ears or hear some noises such as the sound of a helicopter when you drive the vehicle with a rear seat window or the sunroof opened to a certain position.

This phenomenon occurs when air flows in through the rear seat window or the sunroof, creating resonance.

If you adjust the open space of the rear seat window or the sunroof when the wind buffeting occurs, such phenomenon disappears or is reduced.



Warning

- While driving or stopping, do not hold a part of your body such as your hand or head out of the window. You may get injured by a passing vehicle or an outside obstacle.
- Be careful not to get a part of your body such as your hand or head to be caught in the window when operating the window.



Caution

- Operating a number of Window buttons at the same time may damage the fuse that is the over-current protective device or the window system.
- Operating the Window buttons on the driver seat door and a different door in the opposite direction at the same time may damage the window system.

Sunroof*

For your safety, never operate the sunroof when the vehicle is moving.

The sunroof is a secondary window installed on the vehicle roof for supporting pleasant driving such as ventilation and lighting in the vehicle.

The sunroof window can be slide opened and closed and it also operates in a tilting way to lift the rear section of the sunroof up slightly.

The sunroof cover can be opened and closed by hand.

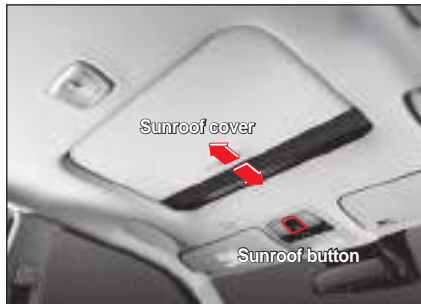

Warning

- While driving or stopping, do not hold a part of your body such as your hand or head out of the sunroof. You may get injured by a passing vehicle or an outside obstacle.

Caution

- The sunroof operates even when the START/STOP switch is in the ON status. However, caution should be taken that using the sunroof excessively while the vehicle is not running may cause depletion of the battery.
- After finishing the sunroof operation, release the Control button. Pressing the Control button continuously may cause a malfunction.
- If the sunroof is opened completely, the wind buffeting may become intensified. In such case, adjust the open space in the sunroof.
- If the sunroof operation part is frozen during winter, operate it after the frozen part melts completely.
- Remove dust and foreign materials from the rubber part around the sunroof window periodically. If dust and foreign materials are present, noise may occur when the sunroof operates and it may cause a malfunction.

Notice

- To operate the sunroof, the START/STOP switch should be in the ON status or the vehicle should be running.

Opening automatically

Press the Sunroof button briefly. The sunroof opens automatically. The rear section of the sunroof (approximately 6 cm) does not open.

To open the sunroof fully, press the Sunroof button again.



Notice

- Operating the switch while the sunroof is opening stops the sunroof operation.

Opening manually

Press and hold down the Sunroof button. The sunroof opens only while you are pressing the button.

To open the sunroof completely, you should press and hold the button.

What is wind buffeting?

Wind buffeting is the phenomenon when you feel pressure upon your ears or hear some noises such as the sound of a helicopter you when you drive the vehicle with a rear seat window or the sunroof opened to a certain position.

This phenomenon occurs when air flows in through the rear seat window or the sunroof, creating resonance.

If you adjust the open space of the rear seat window or the sunroof when the wind buffeting occurs, such phenomenon disappears or is reduced.

Closing automatically

Pull the Sunroof button briefly. The sunroof closes automatically.



Notice

- Operating the switch while the sunroof is closing stops the sunroof operation.

Closing manually

Pull and hold down the Sunroof button. The sunroof closes only while you are pulling the button.

To close the sunroof completely, you should pull and hold the button.

Tilting the sunroof up/down



Tilting up (opening the rear section)

With the sunroof closed, pull the Sunroof button. The rear section of the sunroof will open.

Tilting down (closing the rear section)

With the rear section of the sunroof opened, press the Sunroof button. At this time, the sunroof closes only while the button is being pressed.

To close the sunroof completely, you should press and hold the button.

Sunroof open warning

When you place the START/STOP switch in the ACC or OFF position and open the driver seat door with the sunroof opened, the sunroof open warning buzzer will sound.

When you close the door, the warning buzzer will be turned off.

When the sunroof open warning buzzer sounds, leave the vehicle after closing the sunroof completely.



Caution

- When leaving the vehicle, check if the sunroof is closed completely. Leaving the vehicle with the sunroof opened may cause a robbery case through the sunroof. Also, the inside of the vehicle may get wet when it rains or snows.

Sunroof safety function

The sunroof safety function controls the sunroof to open without closing from its position for safety when it is recognized that a body part or an object is caught in it when the sunroof is closing automatically.



Caution

- The sunroof safety function is not activated for the last section of the sunroof to be closed.
- The sunroof safety function is just an auxiliary system and it is no substitute for the driver's attention. Always exercise caution since it may not operate according to an electrical device or other situations.

Resetting the sunroof

Cases requiring the resetting of the sunroof

- When the battery is depleted or the power supply is suspended with the sunroof opened
- When the sunroof does not open or close completely by operating the button once
- When the sunroof is tilted without stop after it is closed in the sliding method
- When the moving distance has decreased significantly when sliding or tilting the sunroof
- If the sunroof does not operate or operates abnormally when the Sunroof button is pressed

Resetting

With the sunroof tilted up (opening the rear section), pull the Sunroof button continuously for approximately 20 seconds.

- A clicking sound occurs once approximately 5 seconds later and once again approximately 20 seconds later after pulling the Sunroof button. The sunroof resets along with the second clicking sound.
- When you press the Sunroof button slightly after resetting, the sunroof opens and closes again automatically.



Caution

- **If the sunroof does not operate normally after resetting the sunroof, have your sunroof checked and serviced at a KG Mobility Corporation Authorized Service Center.**

Tailgate

The tailgate is a unit that increases the convenience in loading or unloading an article from the vehicle.

The power tailgate allows the user to open and close the tailgate using a simple button operation.

Also, the smart tailgate opens the tailgate automatically when a user approaches to the detection area at the back of the tailgate.



Warning

- Do not disassemble the manual and power tailgate support bars. It is composed of the high pressure devices, which may cause injuries.
- Do not apply heat the manual and power tailgate support bars. It may be damaged by heat and cause injuries.
- Do not dismantle the tailgate's gas lifter. It is composed of the high pressure devices, which may cause injuries.
- Do not heat the tailgate's gas lifter. It may be damaged by heat and cause injuries.
- In order to replace or dispose of the gas lifter, please visit our nearest KG Mobility Authorized Service Center.

Manual tailgate

Opening

- 1 Press the Tailgate open button on the inner side of the tailgate door handle while carrying the smart key.

The tailgate will be unlocked.



- 2 Lift the tailgate up.

Notice

- The range that the tailgate can recognize the smart key is within approximately 1 m.
- When you press the Tailgate open button, only the tailgate is unlocked. The door, motor room hood and other devices remain locked.

Closing

- 1 Hold the inner handle of the tailgate and pull the tailgate down.

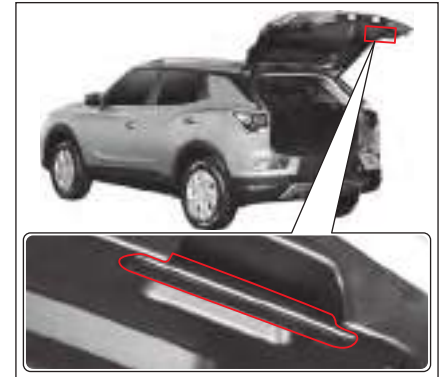

- 2 Close the tailgate by pushing it slightly.



Caution

- When the tailgate is opened and closed with the theft monitoring canceled, the mode is not switched to the theft monitoring mode automatically. Be sure to switch the mode to the theft monitoring mode by pressing the Door lock button on the smart key.

Notice

- When the tailgate is opened and closed in the theft monitoring mode, the mode returns to the theft monitoring mode automatically. At this time, the hazard warning lamp blinks twice and the warning buzzer sounds once.

Power tailgate*

The power tailgate is a unit that allows the user to open and close the tailgate using a simple button operation.

The power tailgate operates when the SBW (shift by wire) is in P (Parking) position with the START/STOP switch in the ON status or in all positions of the SBW (shift by wire) when the vehicle is turned off.

Notice

- If the vehicle speed is 3km/h or faster with the START/STOP switch in the ON status, the tailgate cannot be opened automatically.

Opening/closing with the driver seat's button



- Press and hold the Tailgate button on the driver seat.

After the hazard warning lamp blinks twice and the warning buzzer sounds twice, the tailgate opens or closes.

The tailgate opens if it is closed or it closes if it is opened.

Notice

- When you press the Tailgate button while the power tailgate is opening or closing, the tailgate stops on that position.

Opening/closing with the smart key



- Press and hold the Tailgate button on the smart key.
After the hazard warning lamp blinks twice and the warning buzzer sounds twice, the tailgate opens or closes.
The tailgate opens if it is closed or it closes if it is open.

Notice

- When you press the Tailgate button while the power tailgate is opening or closing, the tailgate stops on that position.

Opening/closing with the button on the tailgate

- Press the Tailgate outside button while carrying the smart key.
After the hazard warning lamp blinks twice and the warning buzzer sounds twice, the tailgate opens.



Notice

- The range that the tailgate can recognize the smart key is within approximately 1 m.
- When you press the Tailgate outside button, only the tailgate is unlocked. The door, motor room hood and other devices remain locked.

Press the Tailgate inside button with the tailgate opened.

After the hazard warning lamp blinks twice and the warning buzzer sounds twice, the tailgate closes.

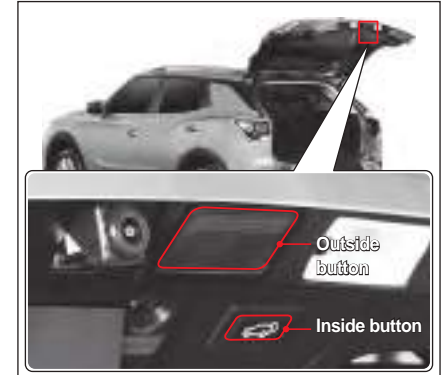

Anti-pinch protection function

The anti-pinch protection function controls the tailgate to stop at that position or open completely for safety when a strong impact is received from the outside or a certain level of force is detected while the power tailgate is opening or closing.



Warning

- **The anti-pinch protection function may not operate if the resistance detected by the power tailgate is smaller than a certain level of force or the tailgate is in the position that it is almost closed.**
- **Do not place a part of your body or an article on the moving path of the tailgate on purpose in order to check the anti-pinch protection function during the power tailgate operation. Doing so may cause serious injury or article and device damage.**



Caution

- **If the anti-pinch protection function operates repeatedly for a number of times, close the tailgate manually and operate it again. If there is an abnormality, have your vehicle checked and serviced at a KG Mobility Corporation Authorized Service Center.**

Resetting the opening height

The maximum opening height of the power tailgate can be reset in accordance with the user's physical condition or other conditions such as the parking space.

- 1 Open the tailgate manually and adjust it to a desired height.
- 2 Press the Power tailgate inside button for 3 seconds or more.
When the resetting is completed, a beep sound occurs.
- 3 Close the tailgate completely by pressing the Power tailgate inside button.

When the opening height is reseted, press the Power tailgate outside button to see if the tailgate opens to the set position.

Resetting the power tailgate

If the power supply is reconnected after the battery is fully depleted or the power supply is disconnected or if the power tailgate does not function normally, reset the power tailgate.

- 1 Park the vehicle on a flat ground and shift the gear shift lever to the P (Parking) position.
- 2 With the Tailgate inside button pressed, press and hold the Outside button for 3 seconds or more.
When the resetting is completed, a beep sound occurs.
- 3 Close the tailgate completely by hand.

When the resetting is completed, check that the power tailgate opens and closes normally.



Caution

- Do not operate the power tailgate in any of the following cases since it may malfunction.
 - When one wheel of the vehicle is lifted up for vehicle check or tire replacement
 - When one wheel of the vehicle is in the air unevenly on a sloping road or paving blocks
 - When the vehicle is parked or stopped on a slope or an uneven surface
- The power tailgate operates even when the START/STOP switch is in the OFF status. However, caution should be taken that operating the power tailgate excessively with the START/STOP switch turned off may cause depletion of the battery.
- When you operate the power tailgate for 5 times or more consecutively, the warning buzzer sounds 3 times and the power tailgate stops in order to prevent the drive motor from being overheated. In such case, stop the operation of the power tailgate for 1 minute or longer and then operate the power tailgate again.

- Do not operate the power tailgate manually if possible.
- If it is necessary to operate the power tailgate manually since it does not operate normally, do not apply excessive force. Doing so may damage the power tailgate unit.
- Do not apply excessive force to the tailgate while the power tailgate is operating. Doing so may damage the power tailgate.
- If you close the tailgate immediately after opening it, the tailgate may not be closed. This is a normal operation. Close the tailgate after a short time interval.
- Do not attach a heavy object to the power tailgate. Doing so may damage the power tailgate.
- Do not modify or repair the power tailgate and relevant components arbitrarily.

Smart tailgate*

The smart tailgate is a function that opens the tailgate automatically when a user carrying the smart key approaches the detection area at the back of the vehicle. This is particularly convenient when you are carrying packages in both hands.

Activating/deactivating the smart tailgate

- You may enable this function at **Vehicle setting** → **Door / Tailgate** → **Smart Tailgate** under  (user settings) in the instrument cluster.



Notice

- You must enable the power tailgate to enable the smart tailgate.

Opening the smart tailgate

Operating condition

- The vehicle should be turned off and all doors and the tailgate should be in locked status (theft monitoring mode).
- You should stay in an area within approximately 1 m from the smart tailgate sensor at the back of the vehicle for approximately 3 seconds or more while carrying the smart key.

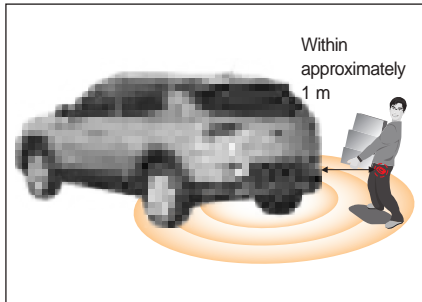

Operation step

The tailgate opens automatically in the following steps after the smart key is detected.



- **Step 1**
The hazard warning lamp and the warning buzzer sound three times at an interval of 1 second (beep- beep- beep-)
- **Step 2**
The hazard warning lamp and the warning buzzer sound three times (beep beep beep)
- **Step 3**
The hazard warning lamp and the warning buzzer sound two times (beep beep)
Next, the tailgate opens.

Stopping the smart tailgate function

- Press any button on the smart key.
- Or, get out of the detection area of the smart tailgate.

Caution

- The smart tailgate begins operating when 30 seconds have passed after entering the theft monitoring mode. This is for preventing the smart tailgate from malfunctioning.
- In any of the following cases, the smart tailgate operation may be delayed or the operating range may change due to frequency interference.
 - When you are in or near a facility where a strong radio frequency is emitted including a police station, government office, broadcasting station, military unit, transmitting tower, airport, harbor, etc.
 - When you carry the smart key along with a mobile phone or a radio set, etc.
- In any of the following cases, the detection range of the smart key may vary, affecting the operation range of the smart tailgate.
 - When one wheel of the vehicle is lifted up for checking the vehicle or replacing tires
 - When the vehicle is parked or stopped on a sloping road or an uneven surface

- Do not stay in the detection area of the smart tailgate unnecessarily while carrying the smart key.
- Familiarize yourself with how to deactivate and stop the smart tailgate function in preparation for an emergency as well as various other situations.
- Be sure to deactivate the smart tailgate function when you wash your vehicle. Failure to do so may cause the tailgate to open automatically, causing a personal injury or damage to the vehicle and other facilities.

Opening the tailgate in the event of emergency

You can open the tailgate using the unlock lever in the tailgate in the event of depletion of the battery, failure of the tailgate devices or other emergency situations.

- 1 Unfold the mechanical key of the smart key or REKES key.

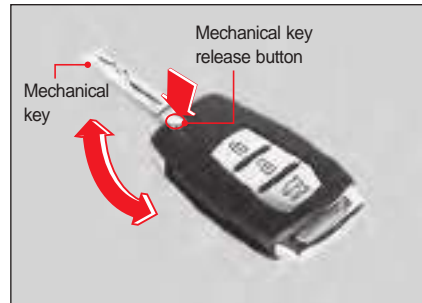

- 2 Insert the mechanical key into the unlock lever hole (1) at the bottom center.

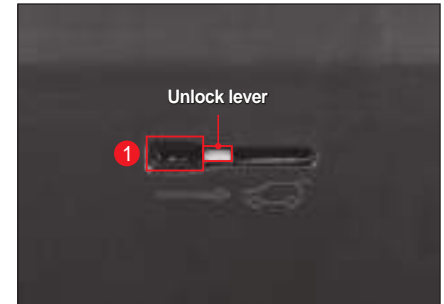

- 3 Press the mechanical key in the direction of the arrow. It unlocks the tailgate.



- 4 Push open the tailgate.



Warning

- Only use the tailgate unlock lever in the event of emergency.
- Do not allow children to play in the luggage compartment. If the tailgate unlock lever operates, opening the tailgate suddenly while driving, a serious accident may occur.



Caution

- Familiarize yourself with the position of the tailgate unlock lever and how to use it in preparation for an emergency.



Warning

- Avoid driving the vehicle with the tailgate open.
 - Exhaust gas may flow into indoors, resulting in gas poisoning.
 - An article from the inside of the vehicle may fall out, causing an accident.
 - The tailgate or other vehicle parts may get damaged.
- Driving the vehicle at a speed of 4km/h or faster with the tailgate open, the tailgate open warning light turns on and the warning buzzer sounds 10 times. Move the vehicle to a safe place immediately and close the tailgate firmly.
- Open or close the tailgate after confirming the safety inside and outside of the vehicle. In particular, be careful not to get a part of an indoor occupant or a near-by person's body caught.
- Be careful not to allow a child to operate the power tailgate or smart tailgate by accident while carrying the smart key. Failure to do so may cause damage to a near-by person, article or vehicle, etc.

- Do not open the tailgate after parking or stopping the vehicle on a sloping road. Doing so may cause an article loaded in the vehicle to fall out, causing injury to a user.
- When you close the tailgate, the tailgate may close suddenly due to the weight of the tailgate and other external factors. Be cautious for preventing injury when closing the tailgate.

Motor room hood

Opening the motor room hood

- 1 Pull the motor room hood open lever (1) located at the bottom left side of the driver seat. The motor room hood will be opened slightly.

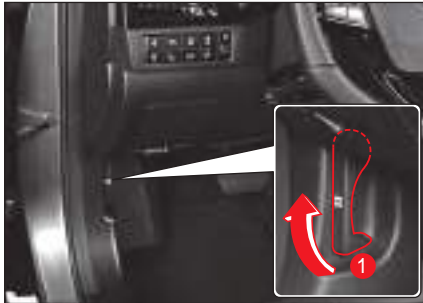

- 2 Lift the motor room hood slightly to pull the motor room hood latch lever (2) up and lift up the motor room hood completely.

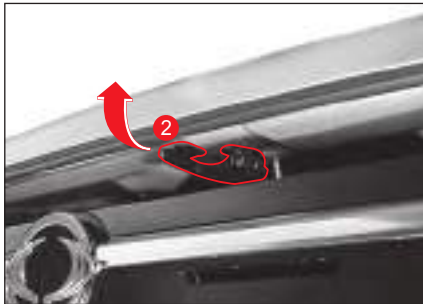

- 3 Holding the motor room hood open with one hand, grip on the sponge attachment (3) on the prop rod to remove the rod from its fixing hook (4) by lifting it up.

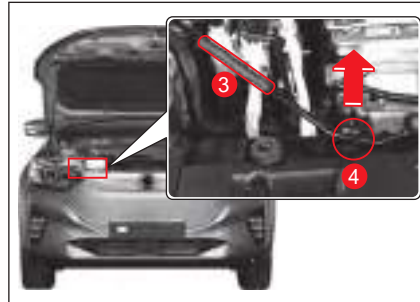

Warning

- To prevent burns, always hold the sponge attachment when you hold the prop rod.

- 4 Insert the free end of the rod into the slot (5) so that the rod supports the hood securely.

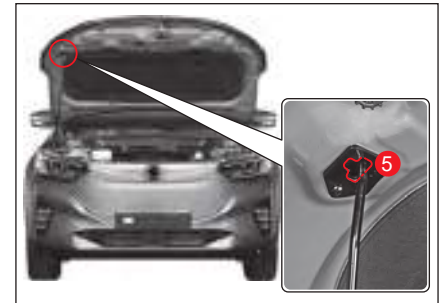

Caution

- Do not shake the motor room hood panel with your hand or close the motor room hood forcibly while the prop rod is fixed to the slot. The motor room hood panel could be damaged.

Closing the motor room hood

Checking before closing the motor room hood

- Make sure that all inlet caps in the motor room hood are closed properly.
- Check that no unnecessary items including gloves and tools are left in the motor room hood.

Closing motor room hood

- 1 Hold the motor room hood with one hand and remove the prop rod from the slot.
- 2 Fasten the prop rod to its retaining hook.
- 3 Lower the motor room hood by about 30 cm and release your hand. The motor room hood closes itself by its own weight.
- 4 Ensure that the motor room hood is securely closed.



Caution

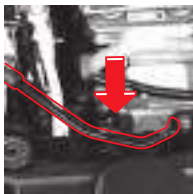

Make sure that the prop rod is fastened to its retaining hook completely before closing the hood.



Warning

- Turn off the ignition before opening the motor room hood. However, if check and service should be performed with the vehicle started, take special care not to be injured or electrocuted by the operating device in the motor room.
- Check the motor room hood in a place where no wind blows. You may get injured if the motor room hood is closed by wind.
- Be careful not to get any of your body parts such as fingers caught when closing the motor room hood.
- Confirm that the motor room hood is closed completely before driving. If you drive the vehicle with the motor room hood open, the vehicle may get damaged and it may block the driver's vision, causing a serious accident.

EV charge port door

Opening EV charge port door

The charging door can only be open when the driver's door is unlocked.

- 1 Depress the brake pedal and leave the parking brake applied.
- 2 Shift the SBW (shift by wire) to the P (Parking) position.
- 3 Be sure to turn off the vehicle.
- 4 Push on the center edge of the charge port door in the arrow direction.



⚠ Caution

- If the charge port door is frozen during winter, do not open it forcibly. Open it by gently tapping on the edge of the cover.

Notice

- If the charging door is locked, it can be open:
 - When ignition switch is turned on or for a certain period of time after it is changed from ON to OFF.
 - For a certain period of time after pressing the smart key unlock button.
 - For a certain period of time after opening or closing the driver's door.

- 5 Open the charge port door completely by pulling it in the arrow direction.

Notice

- When the charging door is open, the charging status indicator is lit up in white.

- 6 Remove the dust cover for the charge port.

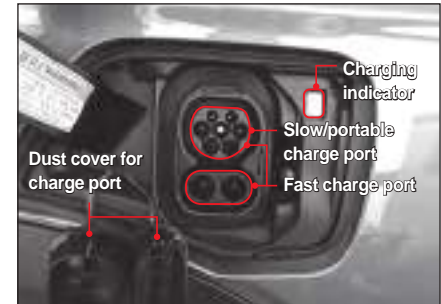

Closing EV charge port door

- 1 Fit the dust cover for the charge port.
- 2 Press on the center edge of the charge port door to close.
- 3 If you press the charging door hard to close it, it may reopen. At this time, close it gently again.

Charging type and precautions

- The charging time can be changed based on the environment (temperature, humidity, vehicle and charger conditions) during charging.
- The shape and procedure may vary depending on the manufacturer. Follow the instructions on the manual provided by the manufacturer.

Slow charging

Use a slow charger in a public charging station.



Notice

- It takes about 11 hours to fully charge the battery when using a 7 kW charger.

Fast charging

Use a fast charger in a public charging station. Follow the instructions on the manual provided by the manufacturer.



Warning

- Consecutive or repetitive fast charging may lead to the impaired battery capacity or reduced service life. Use a fast charger only in an emergency as much as possible.

Notice

- It takes about 54 minutes to charge to 80% using a 50kW-level fast charger at room temperature. (possible to charge to 100%)
- It takes about 33 minutes to charge to 80% using a 100kW-level fast charger at room temperature. (possible to charge to 100%)
- The time it takes to charge may vary depending on the condition and life of the high voltage battery, the specification and condition of the charger, and the ambient temperature.

Portable charger

In the event of an emergency you can charge the battery from an ordinary household outlet (220 V) using a portable charger.



Notice

- Please keep in mind that there could be problems related to electricity bills and electrical load when charging from a household outlet.
- It takes about 25 hours to charge to 100% using a portable (emergency) charger at room temperature.
- The time it takes to charge may vary depending on the condition and life of the high voltage battery, the specification and condition of the charger, and the ambient temperature.

Warning

- The shape and procedure may vary depending on the manufacturer. Follow the instructions manual provided by the manufacturer when charging a battery.
- The electromagnetic wave generated by the charger can affect a medical device (cardiac pacemaker, etc.) If you or your friend is using a medical device, consult with the healthcare professionals and/or representative of the manufacturer regarding the effects that charging may have on implanted devices before using a charger.
- Make sure there is no dirt, dust or any fluid on the charging connector and the plug before connecting to the charge port. Failure to do so may cause an accident, fire or electric shock.
- When connecting the charging connector and plug, be careful to never let your any body part come in contact with engagement part. This may cause an electric shock.

Warning

- Do not pull the charge cable when connecting and disconnecting the charge cable and plug. Always hold the charge cable and the plug itself firmly when connect and disconnect them.



Charging plug
(Charger side)

Charging plug
(Charger side)



Warning

- To avoid an electric shock, read and observe the following instructions:
 - Use a waterproof charger.
 - Never touch the high-voltage parts including the connector and plug when your hand is wet.
 - Do not stand on a non-insulated surface, such as puddle or a metal sheet, when connecting the charging connector and plug to charge the battery.
 - Avoid using a charger in rainy or humid weather as much as possible.
 - Avoid charging when there is lightning and frequent buildup of static electricity as much as possible.
- Immediately stop charging when you find abnormal symptoms, such as an odor, smoke. And have the vehicle checked and service at the KG Mobility authorized dealer or KG Mobility service center.
- Do not use a damaged charge cable (stripped, stepped, etc.) and replace it with a new one.
- Make sure to use a charge cable for slow charging provided by KG Mobility.
- When using a charge cable for slow charging, never use a separate extension cable or adaptor.



Caution

- Keep the charge cable and plug clean and dry.
- Make sure to turn the START/STOP switch OFF before charging the HV battery.
- The cooling fan may operate unexpectedly to control the battery temperature during HV battery charging.
- Do not apply physical shocks to the charging connector and plug. They can be damaged or malfunction.

Connecting and disconnecting of charging connector

For driver's safety, the EV charging system allows the charging connector to be disconnected only when the connector release button is pressed.

Connecting charging connector

- 1 Open the charge port door and remove the dust cover for the charge port.
- 2 Check if there is any dust or fluid on and around the charge port.
- 3 Align the charging connector to the charge port and insert completely.

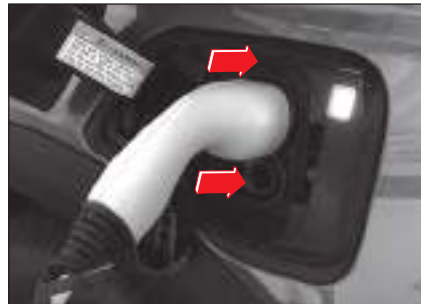

Notice

- If the green indicator lights up immediately after plugging in the charging plug, the connection is normal.
- If the indicator comes on red, pull the connector from the port and then reconnect.

Disconnecting charging connector

- 1 Check the charging indicator is illuminated solid green or press the Stop charging button.
- 2 When charging is complete, disconnect the charging plug.

Warning

- Failure to follow the above instruction leads to malfunctions of the HV battery and related units or can cause fire and/or electric shock. Disconnect the charging connector in a controlled manner.
- For electric vehicle charging system, for the safety of the driver, a confirmation message (voice message saying charging is complete) indicating the end of charging must appear before the charging plug can be disconnected.

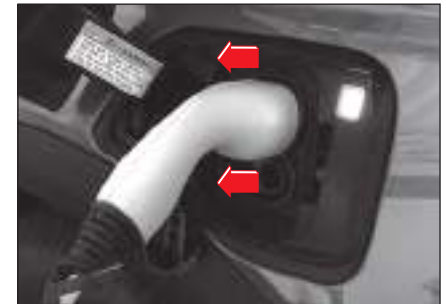

Emergency removal of charging connector

In an emergency, where the charging connector cannot be removed because of charging system malfunctioning or abnormality during charging, use the following procedure to remove the connector.

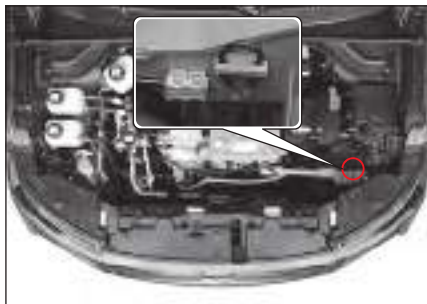

- 1 Open the motor room hood.
- 2 Pull the emergency release cable (A) for charging connector.

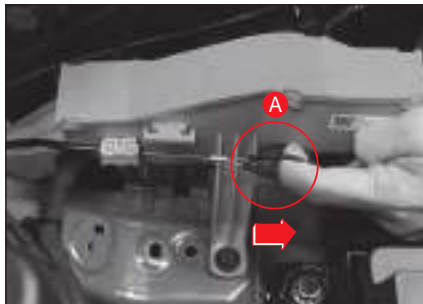

- 3 Check the charging connector is released before removing it.

Charging connector lock

The charging connector lock prevents the charging connector from being removed and locks it in the charge inlet securely.

This function is useful to remove the cable when using a fast charger at a public charging station for the next user.

Locking charging connector

The charging connector lock can be activated by using the AUTO charge plug lock button in the vehicle interior.



Charging status	AUTO plug lock button	
	Indicator OFF (Lock mode)	Indicator ON (Auto mode)
Before charging (Ready)	Locked	Unlocked
During charging	Locked	Locked
Charging completed	Locked	Unlocked

However, in the case of indicator off (Lock mode), the charging plug is locked only when the driver's door is locked.

- AUTO charge plug lock button indicator OFF
Plugging the charging connector into the charge port activates the charge plug lock. This function remains active until the driver unlocks the connector.

Notice

- **When the doors are unlocked, the charging connector lock is also unlocked.**

- AUTO charge plug lock button indicator ON
The charging connector will be locked when the charging process starts after plugging in the connector.
The charging connector will be automatically unlocked when the charging process is completed.

Caution

- **Use AUTO cable lock function when using a public charger for the next user.**
- **If you use portable (emergency) charger in AUTO cable lock mode, please keep in mind that someone can take the charger once the charging process is completed.**
- **For public fast charger, the charging plug is always unlocked when charging is finished, whether in AUTO mode or LCOK mode, for the next user.**



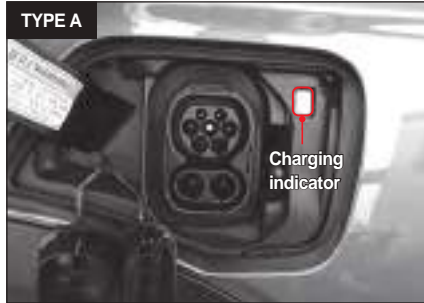

Charging indicator

The charging indicator indicates the status of charging system. It informs the driver of a charging system malfunctioning or abnormality during charging.



Notice
<ul style="list-style-type: none"> The SoC of the HV battery can be check on the instrument panel or charger display.

Charging status indicator

Charging indicator behavior	Meaning
 Lit in white	Charging door open
 Lit in green	Charging plug connected or charging completed
 Flashing in green	Charging in progress
 Flashing in red	Problem with charging system or poor charging plug connection
 Lit in blue	Waiting for scheduled charging

Slow and fast charging

Charging procedures

- 1 Depress the brake pedal and leave the parking brake applied.
- 2 Move the electronic shift lever into P (park).
- 3 Turn off the vehicle.
- 4 Press on the center edge of the charge port door in the direction of the arrow.



- 5 Pull the charge port door in the direction of the arrow to open it.



- 6 Open the charge port door and remove the dust cover for the charge port.
- 7 Check if there is any dust or fluid on and around the charge port.

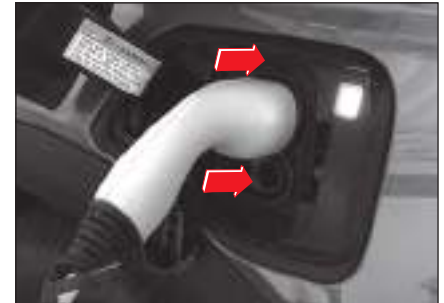

- 8 Align the charging connector to the charge port and insert completely.

Notice

- If the green indicator lights up immediately after plugging in the charging plug, the connection is normal.
- If the indicator comes on red, pull the connector from the port and then reconnect.

- 9 Activate the charging connector lock by pressing the AUTO charge plug lock button.



Charging status	AUTO plug lock button	
	Indicator OFF (Lock mode)	Indicator ON (Auto mode)
Before charging (Ready)	Locked	Unlocked
During charging	Locked	Locked
Charging completed	Locked	Unlocked

However, in the case of indicator off (Lock mode), the charging plug is locked only when the driver's door is locked.

- AUTO charge plug lock button indicator OFF
Plugging the charging connector into the charge port activates the charge plug lock. This function remains active until the driver unlocks the connector.

Notice

- **When the doors are unlocked, the charging connector lock is also unlocked.**

- AUTO charge plug lock button indicator ON
The charging connector will be locked when the charging process starts after plugging in the connector.
The charging connector will be automatically unlocked when the charging process is completed.

- 10 Start charging.

- 11 Check if the HV battery charging indicator (S+) is turned on the instrument panel.

Caution

- To charge the battery, the electronic shift lever should be in P (park) position.
- The radio interference may occur during HV battery charging.
- You cannot move the electronic shift lever out of P (park) position while charging in progress.
- Some devices including the cooling fan may operate unexpectedly to control the battery temperature during HV battery charging. In this case, A/C system is activated which can lead to reduced cooling performance.

Notice

- If the charging indicator is turned off the charging process will not start.
- If the charging indicator is not illuminated, reconnect the charging connector.
- To use basic electronics of the vehicle during charging, set the START/STOP switch to ACC & ON. (The remaining charging time may vary based on the electronics that are being used)
- You can check the charging status by checking the indicator on the charge port door.
 - Blinks Green: Battery charging in progress
 - Solid Green: Charging completed



- 12 When charging begins, the estimated time to charge is displayed on the instrument cluster for a period of time.

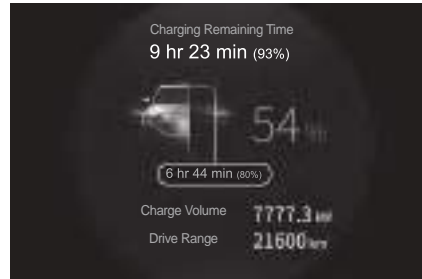

Notice

- When the driver's door is open during charging, the estimated time to charge is also displayed on the instrument panel for a period of time.
- If scheduled charging is set, the estimated time to charge is displayed as “__ hours __ minutes”.

After completing charging

- 1 If the charging is completed with the AUTO charge cable lock activated, press the AUTO plug lock button to unlock the connector.

Notice

- It can also be unlocked by pressing the UNLOCK button on the smart key.

Notice

- Methods to finish slow/quick and portable charging added
 - Press UNLOCK button on smart key for more than 2 seconds to finish charging
 - Press STOP CHARGING button on AVN to finish charging



Charging status	AUTO plug lock button	
	Indicator OFF (Lock mode)	Indicator ON (Auto mode)
Before charging (Ready)	Locked	Unlocked
During charging	Locked	Locked
Charging completed	Locked	Unlocked

However, in the case of indicator off (Lock mode), the charging plug is locked only when the driver's door is locked.

- AUTO charge plug lock button indicator OFF
Plugging the charging connector into the charge port activates the charge plug lock. This function remains active until the driver unlocks the connector.

Notice

- **When the doors are unlocked, the charging connector lock is also unlocked.**

- AUTO charge plug lock button indicator ON
The charging connector will be locked when the charging process starts after plugging in the connector.

The charging connector will be automatically unlocked when the charging process is completed.

- 2 When charging is complete, disconnect the charging plug.

Warning

- Failure to follow the above instruction leads to malfunctions of the HV battery and related units or can cause fire and/or electric shock. Disconnect the charging connector in a controlled manner.
- For electric vehicle charging system, for the safety of the driver, a confirmation message (voice message saying charging is complete) indicating the end of charging must appear before the charging plug can be disconnected.

 Refer to "Emergency removal of charging connector" (p.3-39)



- 3 Check if there is any dust or fluid on and around the charge port and install it.



- 4 Press on the center edge of the charge port door to firmly close.
- 5 If you press the charging door hard to close it, it may reopen. At this time, close it gently again.



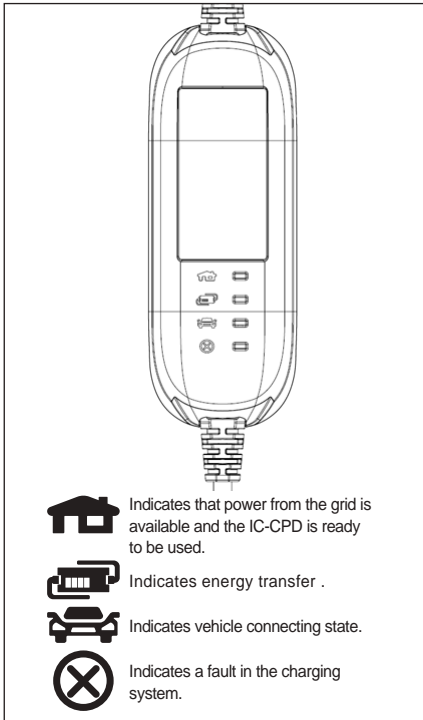

Portable charger

Operating status and faults of control box













The 4 indicators on the front of the portable charger allow the user to identify the operating status of the portable charger and faults.



Explanation For Normal Working State (○ : ON, ● : OFF, ☀ : Blink)

Working State					Description
Self-test state	☀ (1Hz)	☀ (1Hz)	☀ (1Hz)	☀ (1Hz)	Self-test for system
Standby state	○	●	●	●	No plug temp fault (derating) occurred.
				☀ (0.25Hz)	Plug over temp (derating) occurred.
Charging state	○	○	☀ (0.25Hz)	●	No plug temp fault (derating) occurred
				☀ (0.25Hz)	Plug over temp (derating) occurred
Charging stop state	○	○	○	●	No plug temp fault (derating) occurred
				☀ (0.25Hz)	Plug over temp (derating) occurred

Explanation For Error State (○ : ON, ● : OFF, ☀ : Blink, ☀* : Blink)

Working State					Description
Interface home	 (1Hz)	●	●	○	PE Break Error
					Live PE
					AC Voltage Error
	 (1Hz)	●	●	 (1Hz)	Plug Over Temp Error
Control Box	●	 (1Hz)	●	○	L/N Relay Contactor Error
					PE Relay Contactor Error
	●	 (1Hz)	●	 (1Hz)	Board Temperature Error
					Plug Temp sensor Error
					L/N Leakage Self-check Error
					PE Leakage Self-check Error
Vehicle	●	●	 (1Hz)	○	Overcurrent Error
					CP Signal or diode error
	●	●	 (1Hz)	 (1Hz)	L/N Leakage Error
					PE Current Error

When you cannot drive to a public charging station because of low battery level, you can charge the battery from an ordinary household outlet (220 V) using a portable charger (optional).



- 1 Power plug
- 2 Control box
- 3 Charging connector

Warning

- When this charger is connected to a household outlet, it may exceed the capacity of the power distributor, resulting in safety problems such as electrical shutdown and fire. Check the power capacity before charging the vehicle.



Notice

- Please keep in mind that there could be problems related to electricity bills and electrical load when charging from a household outlet.
- It takes about 25 hours to charge to 100% using a portable (emergency) charger at room temperature.

Charging procedures

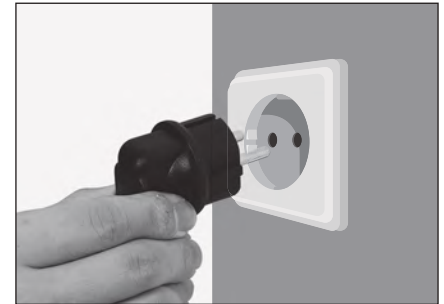
- 1 Check the rate current for the household outlet (220 V). (Rated current for portable charger: 10 A)
- 2 Plug the power plug into the power outlet (220 V).



Rated Current	Rated Voltage	Frequency	Rated Residual Current	Plug
10A	230V	50Hz	AC: 30mA DC: 6mA	EU MIAN TYPE E/F 
10A	230V	50Hz	AC: 30mA DC: 6mA	BRITISH TYPE G 
8A	230V	50Hz	AC: 30mA DC: 6mA	SWISS TYPE J 

3 Check the display on the control box.



Notice

- Check rear side of the control box for more information regarding control box display.

4 Depress the brake pedal and leave the parking brake applied.

5 Move the electronic shift lever into P (park).

6 Turn off the vehicle.

7 Press on the center edge of the charge port door in the direction of the arrow.



8 Pull the charge port door in the direction of the arrow to open it.



9 Open the charge port door and remove the dust cover for the charge port.

10 Check if there is any dust or fluid on and around the charge port.

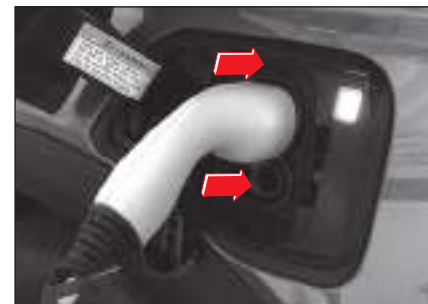

11 Align the charging connector to the charge port and insert completely.

Notice

- If the green indicator lights up immediately after plugging in the charging plug, the connection is normal.
- If the indicator comes on red, pull the connector from the port and then reconnect.

- 12 Activate the charging connector lock by pressing the AUTO charge plug lock button in the vehicle.



Charging status	AUTO plug lock button	
	Indicator OFF (Lock mode)	Indicator ON (Auto mode)
Before charging (Ready)	Locked	Unlocked
During charging	Locked	Locked
Charging completed	Locked	Unlocked

However, in the case of indicator off (Lock mode), the charging plug is locked only when the driver's door is locked.

- AUTO charge plug lock button indicator OFF
Plugging the charging connector into the charge port activates the charge plug lock. This function remains active until the driver unlocks the connector.

Notice

- **When the doors are unlocked, the charging connector lock is also unlocked.**

- AUTO charge plug lock button indicator ON
The charging connector will be locked when the charging process starts after plugging in the connector.

The charging connector will be automatically unlocked when the charging process is completed.

- 13 Start charging.

- 14 Check if the HV battery charging indicator (S+) is turned on the instrument panel.

! Caution

- To charge the battery, the electronic shift lever should be in P (park) position.
- The radio interference may occur during HV battery charging.
- You cannot move the electronic shift lever out of P (park) position while charging in progress.
- Some devices including the cooling fan may operate unexpectedly to control the battery temperature during HV battery charging. In this case, A/C system is activated which can lead to reduced cooling performance.

Notice

- If the charging indicator is turned off the charging process will not start.
- If the charging indicator is not illuminated, reconnect the charging connector.
- To use basic electronics of the vehicle during charging, set the START/STOP switch to ACC & ON. (The remaining charging time may vary based on the electronics that are being used)
- You can check the charging status by checking the indicator on the charge port door.
 - Blinks Green: Battery charging in progress
 - Solid Green: Charging completed



- 15 When charging begins, the estimated time to charge is displayed on the instrument cluster for a period of time.

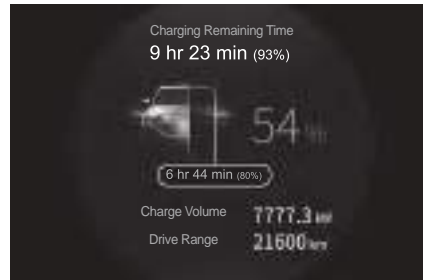

Notice

- When the driver's door is open during charging, the estimated time to charge is also displayed on the instrument panel for a period of time.
- If scheduled charging is set, the estimated time to charge is displayed as “__ hours __ minutes”.

After completing charging

- 1 If the charging is completed with the AUTO charge cable lock activated, press the AUTO plug lock button to unlock the connector.

Notice

- It can also be unlocked by pressing the UNLOCK button on the smart key.

Notice

- Methods to finish slow/quick and portable charging added
 - Press UNLOCK button on smart key for more than 2 seconds to finish charging
 - Press STOP CHARGING button on AVN to finish charging



Charging status	AUTO plug lock button	
	Indicator OFF (Lock mode)	Indicator ON (Auto mode)
Before charging (Ready)	Locked	Unlocked
During charging	Locked	Locked
Charging completed	Locked	Unlocked

However, in the case of indicator off (Lock mode), the charging plug is locked only when the driver's door is locked.

- AUTO charge plug lock button indicator OFF
Plugging the charging connector into the charge port activates the charge plug lock. This function remains active until the driver unlocks the connector.

Notice
<ul style="list-style-type: none"> • When the doors are unlocked, the charging connector lock is also unlocked.

- AUTO charge plug lock button indicator ON
The charging connector will be locked when the charging process starts after plugging in the connector.
The charging connector will be automatically unlocked when the charging process is completed.

- 2 When charging is complete, disconnect the charging plug.

Warning

- Failure to follow the above instruction leads to malfunctions of the HV battery and related units or can cause fire and/or electric shock. Disconnect the charging connector in a controlled manner.
- For electric vehicle charging system, for the safety of the driver, a confirmation message (voice message saying charging is complete) indicating the end of charging must appear before the charging plug can be disconnected.

☞ Refer to "Emergency removal of charging connector" (p.3-39)

- 3 Check if there is any dust or fluid on and around the charge port and install it.



- 4 Press on the center edge of the charge port door to firmly close.
- 5 Remove the plug of the portable charger from the power outlet (220 V).
- 6 Fit the dust cover on the charging connector.
- 7 Store the portable charger in a safe place and keep it from dirt or dust.

Warning

- Use a portable charger which is a genuine part of KG Mobility.
- Do not attempt to modify, disassemble, or service any part of the portable charger.
- Never use a separate extension cable or adaptor when using a portable charger. Failure to do so may cause a fire.
- Do not use the portable charger if it is abnormal.
- If the cable of the portable charger is stripped, excessively bent or there are dings on it, do not use the charger.
- Never use the portable charger, if there are signs of damage in the control box, power plug, charging connector part of it.

Warning

- Do not touch or use the portable charger connector with your wet hand or in very humid conditions.
- Always use the portable charger within the rated voltage.
- Keep out of the reach of children or incompetent persons. Understanding the safety precautions and risks thoroughly is necessary to use this device.
- Do not step on the portable charger cable or place items on it.
- Make sure that the cable of the portable charger is not twisted.
- Do not charge the vehicle when there is lightning.
- Never charge the battery near fire or heat.

Caution

- Keep the power plug and charging connector clean and free from any fluid and/or dust.

How to store and care for slow charging cable



Store the slow charging cable in the luggage compartment.

Scheduled charging

How to perform scheduled charging

The user can charge the high voltage battery at a set time through the AVN system.



Caution

- For scheduled charging, the user must use a slow charger or portable charger.

Notice

- For details on scheduled charging, please see the audio manual provided separately.
- Configurable items in AVN
 - Scheduled charging
 - Target battery charging amount
 - Charging current

- 1 Set the scheduled charging on the AVN screen.
 - Select Setup → Electric vehicle settings → Prioritize discount time and Target battery charging amount on the AVN screen.

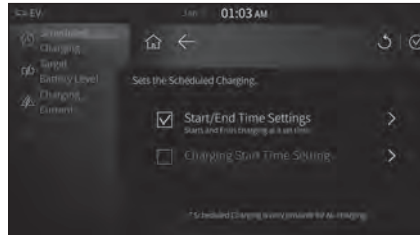

Notice

- Set to start/stop charging preferentially during discount time (Charging will take precedence at the set time zone.)
- Set charging start time to reach target charging amount (Charging starts at the set time.)

- 2 Install the charging plug in the vehicle according to the full charging procedures and portable charging procedures.
 - ☞ Refer to “Slow and fast charging” (p.3-42)
 - ☞ Refer to “Portable charger” (p.3-46)

To charge immediately after canceling scheduled charging

- 1 Even when the slow charging and portable charging plugs are connected while the scheduled charging is set, the high voltage battery will not be charged until the scheduled time is reached. In this case, press the Scheduled Charging OFF button.

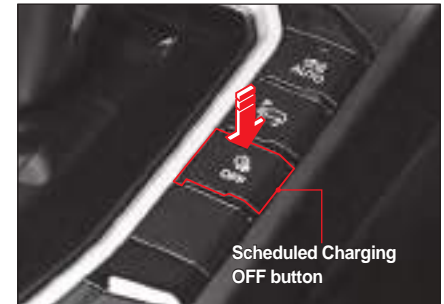

- 2 This will temporarily turn off scheduled charging, and start high voltage charging immediately.



Caution

- To be able to charge immediately, you must press the Scheduled Charging OFF button within 3 minutes of plugging in the charging plug.

Lights and lamps

Outdoor lights/lamps

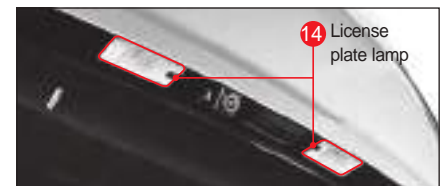
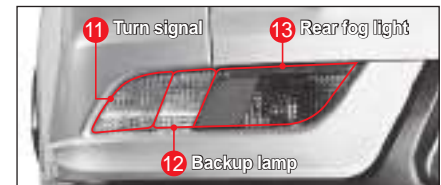
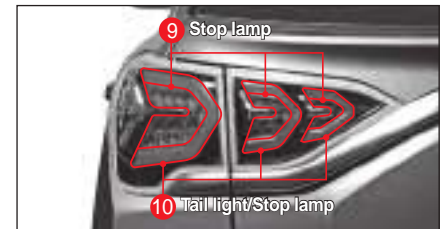
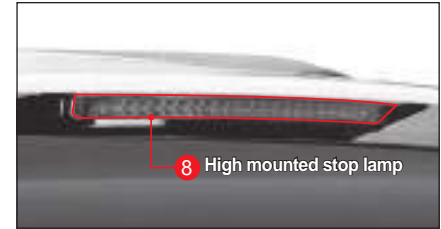
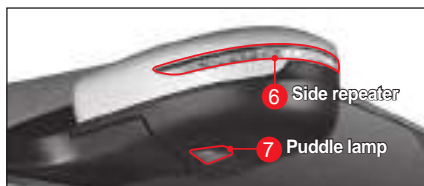
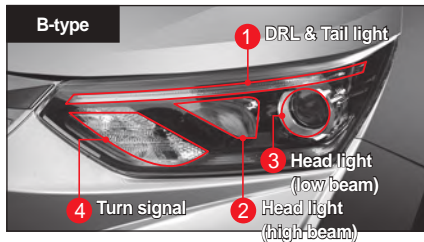
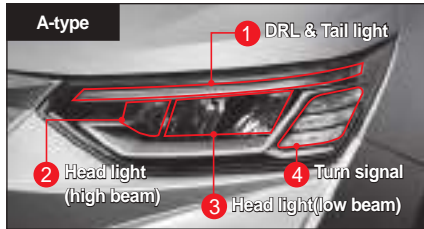

Light switch

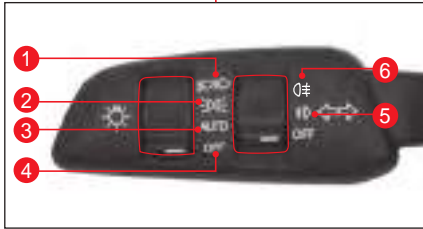

- 1 Head light
- 2 Tail light
- 3 Auto light function
- 4 Turning off all lights
- 5 Front fog light
- 6 Rear fog light

Turning on the head light

The head light turns on along with the sidelight, tail light, license plate lamp, front fog light (in the ON status) and other interior lights.

Turning on the tail light

The tail light turns on along with the sidelight, license plate lamp, front fog light (in the ON status) and other interior lights.

AUTO Activating the auto light function*

The head light and the tail light turn on or off automatically according to the amount of sunshine received by the auto light sensor.

Turning on Smart High Beam (SHB)

Pushing the Light switch in the direction of instrument cluster with the Light switch in the AUTO position activates the SHB.

 Refer to "Smart High Beam (SHB)"* (p.3-60)

OFF Turning off all lights

All lights turn off.

Notice

- For the vehicles without the auto light and fog lamp, the light switch has no corresponding function.

Turning on the front fog light*

When you place the Light switch in the  (front fog light) position with the head light or the tail light on, the front fog light turns on.

Turning on the rear fog light*

With the headlights turned on, if you rotate the switch in  position, rear fog lights turn on and the switch returns back in front fog light position. Rear and front fog lights turn on simultaneously.

Turning it again will turn off the rear fog lamp.

OFF Turning off the fog light*

The fog light turns off.

Turning on/off the left/right turn signal

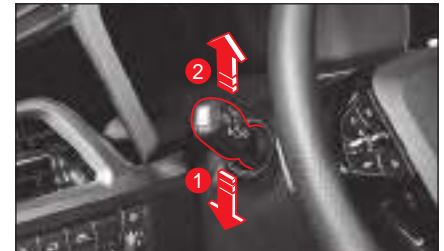

- When you push the Light switch down (1), the left turn signal blinks. At this time, the turn signal on the instrument cluster also blinks.
- When you push the Light switch up (2), the right turn signal blinks. At this time, the turn signal on the instrument cluster also blinks.

Turning on/off the high beam



- When you push the Light switch in the direction of instrument cluster and release it with the low beam on, the high beam turns on. At this time, the high beam indicator on the instrument cluster also turns on.
- When you pull the Light switch in the driver's direction and release it with the high beam on, the high beam turns off.

Warning

- Do not turn on the high beam if there is an oncoming vehicle or a vehicle at the front. The high beam may block the other drivers' vision, causing an accident.

Turning on the high beam and low beam at the same time (passing light)

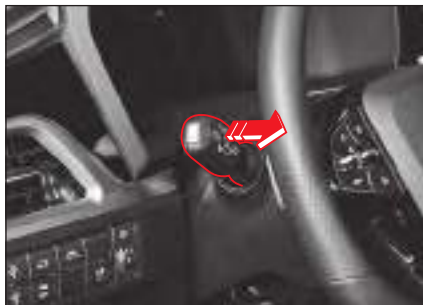

The high beam and the low beam turn on at the same time while pulling the Light switch in the driver's direction.

Notice

- This function operates regardless of the position of the Light switch.

Hazard warning lamp

The hazard warning lamp is used to give warning to other vehicles in the event of emergency for preventing an accident.

- When you press the Hazard warning lamp switch, all turn signals blink.
- When you press the Hazard warning lamp switch again, the hazard warning lamp turns off.

 Refer to "Emergency Stop Signal (ESS)" (p.4-131)

Caution

- Do not operate the hazard warning lamp for a long period of time with the vehicle off. Doing so may cause confusion to other vehicle drivers as well as depletion of the battery.

Notice

- The hazard warning lamp operates regardless of the status of the START/STOP switch
- While the hazard warning lamp is operating, the turn signal does not operate independently.

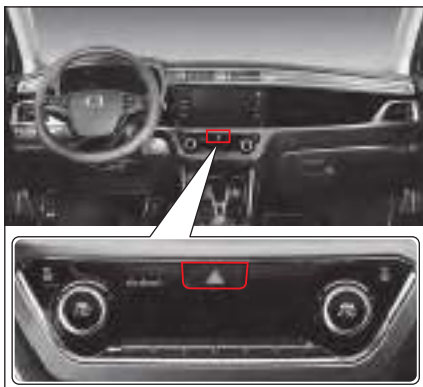

Adjusting the angle of the head light



The front and rear slope of the vehicle may vary depending on the number of occupants, weight and center of gravity of luggage.





In such case, you can adjust the angle of the head light to secure proper vision at night and not to obstruct an oncoming vehicle or a vehicle at the front with a strong light from the head light.

Angle adjustment levels of the head light

The angle of the head light can be adjusted in 4 levels (Levels 0-3) according to the front and rear slope of the vehicle.

- When the vehicle is tilted forward Lower the head light angle adjustment dial (Level 0 direction). The head light is adjusted to face up.
- When the vehicle is tilted backward Raise the head light angle adjustment dial (Level 3 direction). The head light is adjusted to face down.

Angle adjustment standard for the head light

	Number of occupants and loading condition
Level 0 	<ul style="list-style-type: none"> 1-2 occupants (normal driving)
Level 1 	<ul style="list-style-type: none"> 1-2 occupants and luggage (approximately 90 kg) 4-5 occupants
Level 2 	<ul style="list-style-type: none"> 4-5 occupants and luggage (approximately 100 kg)
Level 3 	<ul style="list-style-type: none"> 1 occupant and luggage (approximately 400 kg)

Warning

- Drive the vehicle after adjusting the angle of the head light according to the number of occupants, weight and center of gravity of luggage. Failure to do so may cause an accident.
 - Never drive the vehicle in any of the following cases that go beyond the angle adjustment standard for the head light.
 - Driving the vehicle with level 3 under the condition of level 0 (the angle of the head light is lowered): It takes longer for the driver to recognize an emergency situation on the road ahead if it occurs.
 - Driving the vehicle with level 0 under the condition of level 3 (the angle of the head light is raised): It obstructs the vision of the driver in an oncoming vehicle or a vehicle at the front.
- In such case, it may obstruct safe driving, causing a serious accident.

Daytime Running Light (DRL)*

The DRL also turns on automatically during daytime, allowing you to recognize a vehicle easily.



In case the DRL turns on

- If the switch of the tail light, front fog light and head light is not operated with the START/ STOP switch in the ON (irrelevant to whether the vehicle is started or not) status

Notice

- When the DRL turns on, the tail light also turns on at the same time.
- The same lamp is used for the DRL and the tail light, but the DRL is more bright.

In case the DRL turns off

- When DRL deactivated
- When the START/STOP switch is in ACC or OFF status
- When you turn on the head light or the head light is turned on by the auto light function
- When you turn on the front fog light
- When parking brake (EPB) applied at the vehicle speed of 3 km/h or less (AUTO HOLD switch turned off)

Smart High Beam (SHB)*

The SHB is the function to control the high beam not to obstruct the vision of a driver in an oncoming vehicle or a vehicle at the front with a strong light from the high beam.

The SHB detects the situation through the sensor at the top of the vehicle windshield (front camera module) and turns on or off the high beam automatically.

Setting the SHB

- 1 Place the Light switch in the AUTO position.



- 2 Push the Light switch in the direction of instrument cluster and release it.

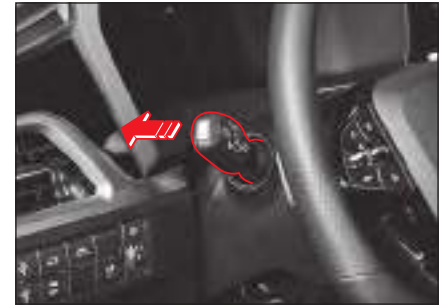

- When the SHB function is activated, the SHB indicator turns on.



SHB indicator

In case the high beam turns on

All the following conditions are set with the SHB activated, the high beam turns on.

- When the vehicle speed is 35 km/h or faster
- When the surrounding area is dark that it is detected as night
- When an oncoming vehicle and a vehicle at the front are not detected

When the light beam turns on automatically, the SHB indicator turns on along with the high beam indicator.



SHB indicator



High beam indicator

In case the high beam turns off

The high beam turns off in any of the following cases.

- When the head light of an oncoming vehicle (including a bicycle and a motor cycle) is detected
- When the tail light of a vehicle (including a bicycle and a motor cycle) at the front is detected
- When it is bright in the surrounding area due to streetlights or other lighting sources in the surrounding roadside.
- When the light source of a tunnel is detected
- When the Light switch is not in the AUTO position
- When the SHB function is deactivated
- When the vehicle speed is less than 35 km/h

Notice

- **When the high beam turns off and then turns on again automatically, there may be a delay time for few seconds.**

Operating the Light switch

The detailed operation of the Light switch with the SHB set and activated is as follows.

- When you push the Light switch in the direction of the instrument cluster with the SHB set and operating, the high beam turns on and the SHB setting is canceled.
- When you pull the Light switch in the driver's direction with the SHB set, the high beam turns on and the SHB setting is maintained only while pulling the Light switch.
- When you pull the Light switch in the driver's direction while the SHB is operating, the high beam turns off and the SHB setting is canceled.
- When you place the Light switch in positions other than the AUTO position, the SHB setting is canceled.



Caution

In any of the following cases, the SHB may not operate normally.

- When the vehicle windshield is damaged or contaminated by dust, mist, fog, sticker, snow, etc
- When the lamp of an oncoming vehicle or a vehicle at the front is damaged
- When an oncoming vehicle or a vehicle at the front is out of your front sight
- When an oncoming vehicle and a vehicle at the front are recognized only partially in an intersection or a winding road
- When there is a light source similar to a vehicle lamp or a reflector at the front
- When an illuminator or a reflector is installed in a construction section, etc.

Welcome light

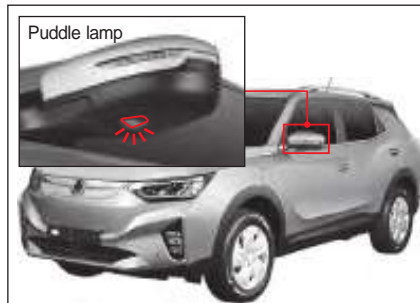

The welcome light is the function that operates the puddle lamp and the door handle lamp in order to increase safety and visibility at night.

If any one of the following conditions is met, the welcome light (puddle lamp and door handle lamp) turns on for approximately 30 seconds.

- When the door UNLOCK button on the smart key is pressed in theft deterrent mode
- When you press the door handle Lock/Unlock button on the smart key in the theft monitoring mode
- When you approach within 1 m from the vehicle in the theft monitoring mode while carrying the smart key

Welcome mode

When you approach the vehicle door while carrying the smart key in the theft monitoring mode, the auto approach lamp (puddle lamp/door handle lamp) turns on.

Goodbye mode

When you turn off the vehicle and open the driver seat door, the auto approach lamp (puddle lamp/door handle lamp) turns on.

In case the auto approach lamp turns off

In any of the following cases, the auto approach lamp turns off.

- When approximately 30 seconds have passed after the auto approach lamp turns on
- When the START/STOP switch is in the ON position
- When the vehicle enters the theft monitoring mode
- When the smart door auto lock is activated

Notice

- **The welcome mode is activated when approximately 30 seconds have passed after the vehicle enters the theft monitoring mode.**
- **The auto approach lamp operates up to 2 times within 10 minutes.**
- You may enable this function at **Vehicle setting** → **Convenience function** → **Approach Welcome or Auto Approach Welcome** under  (user settings) in the instrument cluster.

Coming home/living home light

The coming home/living home light is the function that turns on the head light automatically when the vehicle arrives or leaves in dark environments, increasing the safety and convenience.

Setting the coming home/living home light

- Select **Vehicle setting** → **Light** → **Coming home or / Living home headlamp set time** (time for which the light comes on) under  (user settings) in the instrument cluster.
(Disable, 10 sec, 20 sec and 30 sec)

Operating the coming home light

- When you turn off the vehicle with the head light (low beam) on, the head light (low beam) stays on for the set duration.
- When a certain amount of time has passed with all doors and the tailgate closed, the head light (low beam) turns off.

Notice

- If you maintain the door or the tailgate opened within the set time after turning off the vehicle, the head light (low beam) turns off after 3 minutes.
- When you open and close the door or the tailgate within the set time after turning off the vehicle, the head light (low beam) stays on for the set time and then it turns off.
- When you place the Auto light and Head light (low beam) switches in the OFF position, the head light (low beam) turns off immediately.

Operating the living home light

- When you cancel the theft monitoring mode by pressing the Door unlock button on the smart key or the Door handle switch, the head light (low beam) stays on for the set time.
- When the set time has passed, the head light (low beam) turns off.

Notice

- Conditions for turning off leaving home (low beam off)
 - 1) Set time elapses after leaving-home light turned on
 - 2) Lock signal received from smart key
 - 3) Ignition turned on while leaving-home light in operation

Auto light function*

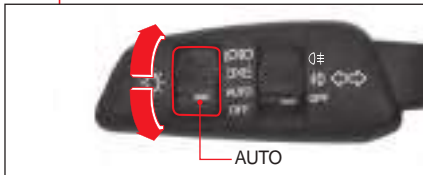
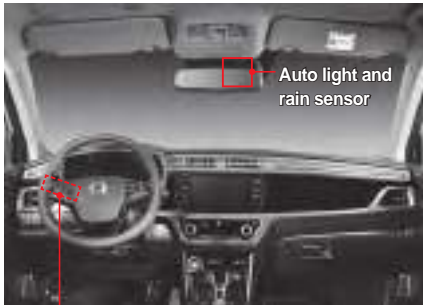

The auto light is the function that detects the amount of sunshine through the sensor and turns on or off the head light and the tail light automatically.

- The auto light function is activated when the Light switch is positioned in the AUTO position.

Auto light sensor

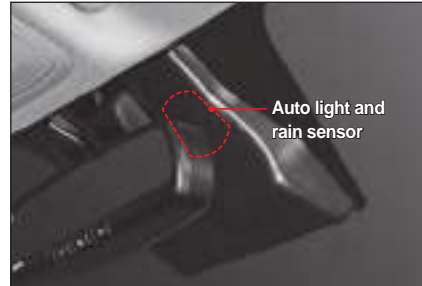

The auto light sensor is integrated with the rain sensor.

Caution

- When you shake or apply an impact to the auto light sensor, the auto light may malfunction.
- Do not wipe the auto light sensor installation part with cleaning agents or wax, etc. The auto light function may malfunction.
- Attaching commercially available window coating or tinting products to the windshield may cause the auto light function to malfunction.
- If the vehicle vibrates significantly just as driving on a road with an uneven surface, the auto light function may malfunction.

Caution

- The time to turn on and off the light may vary depending on a change in the climate condition such as fog, snow and rain and surrounding environment.
- When you change the Light switch to the AUTO position or from the AUTO position to another position, the lights inside the vehicle, tail light and head light may blink momentarily. This is a normal phenomenon for recognizing the status of the auto light.
- When passing through a dark place such as a tunnel, do not depend on the auto light function and turn on the head light manually.
- Use the auto light function for the head light and the tail light limitedly only at the time of sunrise and sunset. In general, operate the head light and the tail light manually.
- Do not use the auto light function for the head light and the tail light on a gloomy day. Operate such lights manually.

Interior lamp

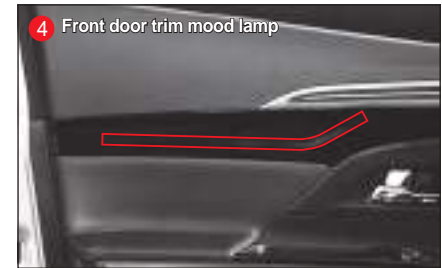
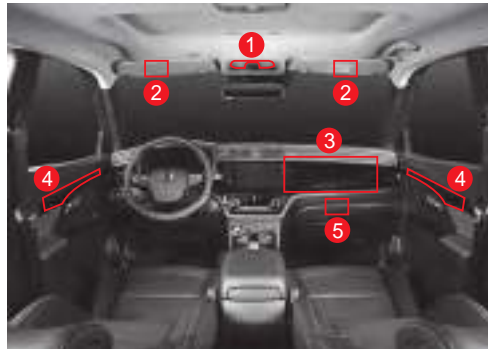
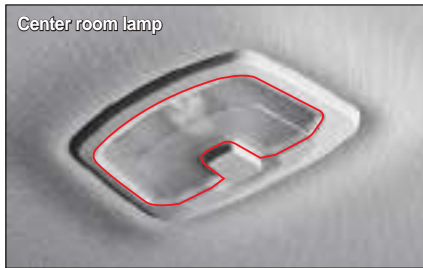
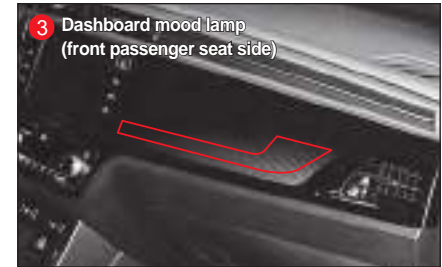
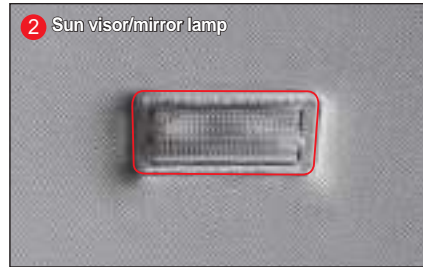

Front room lamp (overhead console)



- ① Driver seat spot switch
- ② Front passenger seat spot switch
- ③ Door linkage switch
- ④ SOS switch

Warning

- **Avoid using the interior room lamp when driving at night or in a dark place. The light of the interior room lamp may obstruct the front vision of a driver, causing an accident.**

Notice

- **When the interior room lamp is turned on after the vehicle is turned off, the room lamp turns off automatically after approximately 10 minutes in order to prevent depletion of the battery.**

Driver seat spot switch

When you press the switch (①), the driver seat front room lamp turns on.

Front passenger seat spot switch

When you press the switch (②), the front passenger seat front room lamp turns on.

Door linkage switch

When you open the door with the switch (③) pressed, the front room lamp and the center room lamp turn on, and when you close the door, those lamps turn off.

SOS switch*

In an emergency, press this switch (④) to connect the contact person of the PSAP (Public Safety Answering Point). When the connection is established, please describe the emergency situation.

Caution

- **Do not use if it is not an emergency. Otherwise, other emergency situations may not be dealt with properly.**

Linkage function between the smart/rekes key and the front room lamp

When you unlock the door using the smart/rekes key with the front room Lamp door linkage switch pressed, the driver seat and front passenger seat room lamps turn on for 30 seconds.

At this time, when you lock the door by pressing the Door lock button on the smart/rekes key, the driver seat and front passenger seat room lamps turn off immediately.

Caution

- Do not leave the door open for a long time with the room lamp linked to the door or leave the vehicle when the room lamp is turned on. If the room lamp stays on for a long period of time, the battery may be depleted.

Center room lamp



- Press the center room lamp switch to turn the lamp on and press it again to turn it off. However, the lamp will come on when you open the door with the door interlock switch (front room lamp) pressed even if the switch is in the "OFF" position.

Caution

- Do not open the door for a long period of time with the Door linkage switch pressed. If the center room/luggage room lamp stays on for a long period of time, the battery may be depleted.
- Do not leave the tailgate not closed completely for long period of time. If the center room/luggage room lamp stays on for a long period of time, the battery may be depleted.

Luggage room lamp



- Pressing the switch (1) turns on the lamp and pressing it again turns it off with the tailgate open. (self-return type)
- When you close the tailgate with the luggage compartment lamp on, the luggage compartment lamp goes off.

Sun visor/mirror lamp

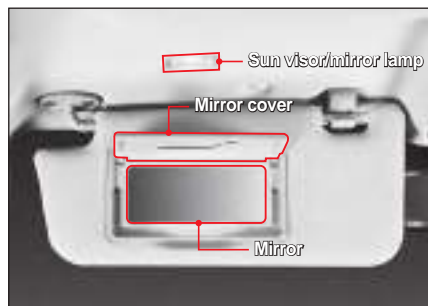

When you pull the sun visor down and open the mirror cover, the lamp turns on.

When you close the mirror cover, the lamp turns off.

⚠ Caution

- Be sure to close the mirror cover after using the sun visor mirror. Failure to do so may cause the sun visor lamp to stay on and the battery may be depleted. Also, an open mirror cover may cause injury.

Notice

- When you pull the sun visor down and use it as a sunshade, you can adjust the position of the sun visor.

e-call (Emergency call)*

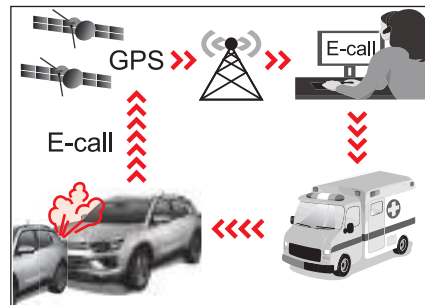

1. Accident occurs
2. Wireless network
3. Call center (PSAP)
4. Emergency center

The e-call is a system to minimize casualties by enabling the relevant information to be passed on to the nearest control center automatically or manually so that immediate action can be taken in case of traffic accidents and emergencies.

- SOS button: When the driver or passenger press this button, e-call is made to the service associate at the PSAP center.
- Test button (Russia only): This button is used to check the system performance. The driver should not press the Test button arbitrarily to activate the test mode.

Notice

- The Test button is the button to enable the test mode, which is used only by experts for the KG Mobility Authorized Service Center to check system performance.

- LED indicator: When turning the ignition on, the red and green LEDs light up for 3 seconds. Then, this LED will go off during normal operation.

In the event of an issue with the system, the red LED lights up or blinks.



Caution

- If the red LED is still lit under normal driving conditions, it may indicate a malfunction of the E-CALL system.
- Contact the nearest authorized KG Mobility dealer immediately to determine whether the E-CALL system is faulty or not.
- Otherwise, normal operation of the E-CALL system is not guaranteed. The vehicle owner is responsible for the consequences of not observing the instruction above.

How to use E-CALL system

AutoCall Mode



The ERA-GLONASS (eCall) device automatically makes an emergency call to a single duty dispatcher service for the timely implementation of rescue operations in the event of a car accident.

For the timely provision of assistance and support, the ERA-GLONASS (eCall) system automatically transmits data on a traffic accident to a single duty dispatcher service.

In this case, the emergency call cannot be terminated by pressing the SOS button, and the ERA-GLONASS (eCall) system remains in the connected state until the Unified Duty Control Service operator receiving the call disconnects the emergency call.

Notice

- In cases of insignificant cost of accidents, the ERA-GLONASS (eCall) system may not make an automatic emergency call. In this case, it is possible to make an emergency call in manual mode by pressing the SOS button.

Notice

- The operation of the system will be impossible if there is no coverage of mobile communication networks and no GPS and GLONASS signal. (In Case of EU : Galileo Added)

Manual Mode



The driver / passenger can make an emergency call in single dispatch service manually by pressing the SOS button to call emergency services.

Call to the emergency service using the ERA-GLONASS system can be canceled by pressing the SOS button again only before establishing a connection with the operator of the single duty-dispatch service. (Russia)

Call to the emergency service using the eCall system can be canceled by re-pressing the SOS button within 3 second. (EU)

After activating an emergency call in manual mode for timely assistance and support system ERA-GLONASS (eCall) transmits data on a traffic accident / other incident to the operator of the single duty dispatcher service during a call for help by pressing the SOS button.

- Stop your vehicle at a safe place.
- Lower the e-call button cover.
- Press the SOS button. (Minimal data set for the vehicle and its location is registered to the mobile network)
- The call is connected to the operator at the e-call center.
- EU: MSD (Minimum Set of Data) sent before the emergency call is made, not after it does
- Russia: MSD (Minimum Set of Data) sent before the emergency call is made, not after it does
- EU: For the manual emergency call, you can cancel within 3 seconds after pressing the button.
- Russia: You can cancel before the call is connected.

Test mode

- Russia: When you have replaced and checked the e-call system, you can use the Test button to activate the SOS test mode.

The driver should not press the Test button arbitrarily to activate the test mode.

There is a technical possibility device performance checks ERA-GLONASS installed on your car. In order to prevent erroneous signals anxiety and malfunctioning device, it is necessary to keep checking the device regularly ERA-GLONASS installed in the auto- mobile phone checks are allowed exclusively authorized to the staff in the service area in accordance with this manual (on enabling user testing interface). ERA-GLONASS device check mode is started by pressing a button. "Test Button". The test mode starts with voice guidance to verify performance device ERA-GLONASS. During the performance test of the ERA-GLONASS device, the red and green LEDs remain on. To deactivate the verification mode during the voice guidance output, it is not necessary to press the SOS test button again.



- EU: When you have replaced and checked the e-call system, you can use the scan tool to activate the SOS test mode.

e-call can't be canceled when:

- e-call is made automatically by crash signal from the air bag unit (terminated when an operator at e-call center ends the call)
- 3 seconds is elapsed since manual emergency call made by pressing the SOS button was connected (for EU)
- Operator at e-call center answers the call, for manual emergency call made by pressing the SOS button

Notice

- **The battery of the ERA-GLONASS (eCall) system provides power for one hour in case the main power supply of the vehicle is turned off as a result of a collision in an emergency situation.**

Notice (Russia only)

- **During the operation of KG Mobility transported vehicles (commercial name Korando) in the territory of the Eurasian Economic Union (EAEU), incl. On the territory of the Russian Federation, with the installed UNIT ASSY-ECALL models, which include a multi-chip SIM / eUICC chip, the installation of additional profiles will be prohibited. And in this case, the packet transmission on these samples will be blocked.**



Warning

I can be dangerous to remain in the vehicle, even if you have pressed the SOS button in an emergency if:

- you see smoke inside or outside of the vehicle, e.g. if there is a fire after an accident
- the vehicle is on a dangerous section of road
- the vehicle is not visible or cannot easily be seen by other road users, particularly when dark or in poor visibility conditions

There is a risk of an accident and injury. Leave the vehicle immediately in this or similar situations as soon as it is safe to do so. Move to a safe location along with other vehicle occupants. In such situations, secure the vehicle in accordance with national regulations, e.g. with a warning triangle.

Notice

1. Our eCall system provides 112-based eCall service only and conforms to the General Data Protection Regulation specified in EU laws.
2. Processing of such data is strictly limited to the purpose of handling the emergency eCall to the single European emergency number 112
3. Type of data and its recipients
 - MSD Data Items
 - 1) Call Type : Auto Call / Manual Call
 - 2) Test Call : Test Call / Emergency Call
 - 3) Position Can Be Trusted : Yes/No
 - 4) Vehicle Type : M1/M2/M3/N1/N2/N3
 - 5) Vehicle identification number
 - 6) Propulsion Storage Type : Gasoline, Diesel
 - 7) RTA event timestamp : Road Traffic Accident event timestamp
 - 8) Vehicle Location : Latitude, Longitude
 - 9) Vehicle Direction : Vehicle orientation at the time of event
 - Call Log Data Items
 - 1) Trigger time : Time of call initiation event (crash detected or button press).
 - 2) DTC : Diagnostic Trouble Code
 - 3) Tigger type : Manual Call / Auto Call / Retry Call
 - 4) RSSI : GSM(2G) or UMTS(3G) signal strength
 - 5) Ec/No : Energy Carrier/ noise power density
 - 6) Call type : GSM(2G) / UMTS(3G) / Reserved
 - 7) Call end status : Reason for call end

4. The 112-based eCall in vehicle system is designed in such a was as to :
 - Ensure that the data contained in the system memory is not available outside the system before an eCall is triggered
 - Ensure that it is not traceable and not subject to any constant tracking in its normal operation status
 - Ensure that data in the system internal memory is automatically and continuously removed
5. The vehicle's owner has a right of access to data and as appropriate to request the rectification, erasure or blocking of data, concerning him or her, the processing of which does not comply with the provisions of Directive 95/46/EC.
6. The data subject has a right to complain to the competent data protection authority if he or she considers that his or her rights have been infringed as a result of the processing of his or her personal data.

Glove box lamp

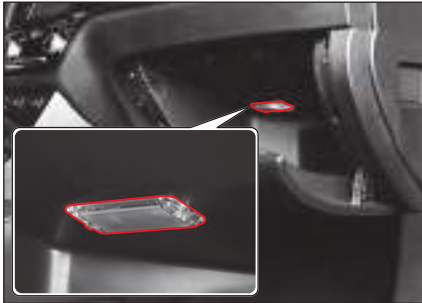

When you open the glove box, the lamp turns on, and when you close the glove box, the lamp turns off.



Caution

- Leaving the glove box opened may cause injury to an occupant in the event of an accident or sudden braking. Be sure to drive the vehicle with the glove box closed.

Mood lamp*

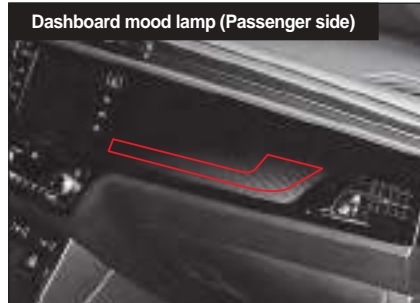

- When the mood lamp is set to enabled, the mood lamp is always lit if the vehicle is started or the ignition switch is turned on.
- When the tail lamp is turned on, the mood lamp gets dim and gives out a soft light.

Mood lamp setting

- 1 Press the MODE button on the AVN or smart audio.
- 2 Press the setting icon on the MODE menu.
- 3 Press the Vehicle Interlock.
- 4 You may select one of six colors and choose auto change or manual color.
- 5 Scroll down to the bottom of the room lamp selection screen to see following additional settings menu:
 - ON/OFF
Turn on and off the entire interior mood lamps.
 - Daytime OFF
Disables in the daytime.

Wiper and washer fluid

Windshield wiper

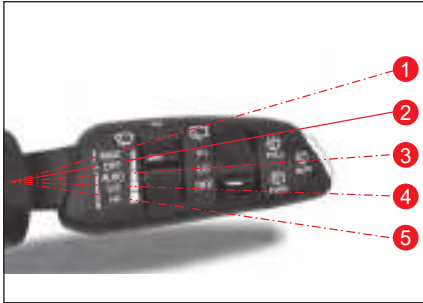

1 MIST

The wiper operates while lifting the wiper operation lever up.

When you release the lever, the level returns to the OFF position and stops.

2 OFF

The wiper stops operating.

3 AUTO

The wiper operation speed is adjusted automatically according to the vehicle speed or the amount of rain (rain sensing wiper).

4 LO

The wiper operates in low speed.

5 HI

The wiper operates in high speed.

Adjusting the operation speed of the windshield wiper

When the wiper operation lever is placed in the AUTO position, the operation speed of the wiper is adjusted.

When you lift the wiper operation speed control lever (6) up, the operation speed of the wiper becomes faster and when you pull the lever down, the operation speed of the wiper becomes slower.

Notice

- When you place the wiper operation lever in the AUTO position with the START/STOP switch in the ON status, the wiper operates once.
- When it becomes dark so that the auto light operates, the wiper speed becomes faster.

Front windshield and washer fluid linkage



This function sprays washer fluid automatically when the windshield wiper is operated.

It operates as follows according to the time to pull the wiper operation lever (7).

- Pull the lever for less than 0.6 second
The washer fluid is sprayed and the wiper operates once.
- Pull the lever for 0.6 second or more
The washer fluid is sprayed and the wiper operates for three times.
- Pull the lever continuously
The washer fluid is sprayed and the wiper operates continuously.

Front auto washer

With the wiper lever placed in the OFF position, press the Front auto washer switch (8).

The washer fluid is sprayed and the wiper operates for four times, and the washer fluid is sprayed again and the wiper operates for three times.

Rear window wiper

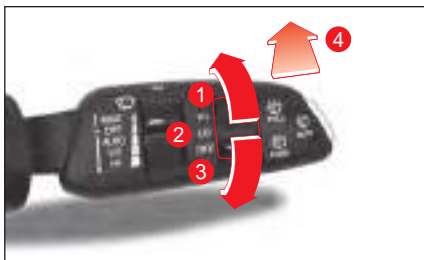

1 HI

The rear window wiper operates in high speed.

2 LO

The rear window wiper operates in low speed.

3 OFF

The rear window wiper stops operating.

Rear window wiper washer fluid linkage function



This function sprays washer fluid automatically when the rear window wiper is operated.

The washer fluid is sprayed and the wiper operates while pushing the wiper operation lever (4).

When you release the lever, the level returns to the OFF position and stops.

Rain sensing wiper*

The rain sensing wiper detects the amount of rain and controls whether or not to operate the windshield wiper and its operation speed automatically.

The rain sensing wiper is activated when the wiper operation lever is placed in the AUTO position.

Rain sensor



The rain sensor is integrated with the auto light sensor.

Warning

- When you place the wiper operation lever in the AUTO position with the START/STOP switch in the ON status, do not touch the windshield where the rain sensor is located or wipe it with damp cloth. Doing so may activate the rain sensing wiper, causing injury to your hand or other body parts.



Caution

- If the windshield is dry, do not only operate the wiper. Doing so may damage the windshield or the wiper blade. Be sure to activate the wiper after spraying the washer fluid.
- Before washing your vehicle, be sure to place the wiper operation lever in the OFF position. Failure to do so may activate the wiper by accident, causing body injury or damage to the vehicle.
- If it is not raining, place the wiper operation lever in the OFF position. It prevents the devices such as the rain sensor from operating unnecessarily.
- Activate the wiper in winter after verifying that the wiper blade is not frozen. Failure to do so may damage the windshield or the wiper blade.

Outside rearview mirror

Folding/unfolding the outside rearview mirror





- When you press the left side of the button (), the outside rearview mirror is unfolded.
- When you press the right side of the button (), the outside rearview mirror is folded.

Auto folding/unfolding function

The following is the function to fold or unfold the outside rearview mirror automatically.

- When the door Lock/Unlock button on the smart key is pressed
- When the door handle Lock/Unlock button is pressed
- When the smart auto door lock function is activated
- When the auto approach function is activated

Activating/deactivating auto folding/unfolding function



- Activating the function
Place the Outside rearview mirror folding/unfolding button in the neutral () position.
- Deactivating the function
Press the left side () or right side () of the outside rearview mirror.

Caution

- **The outside rearview mirror auto folding/unfolding function is activated only when the vehicle has entered the theft monitoring mode.**

Adjusting the outside rearview mirror



- 1 Outside rearview mirror selection dial (L  R)
- 2 Outside rearview mirror control switch ()

Selecting the outside rearview mirror

Turn the selection dial (1) to the left or the right and select a mirror you wish to adjust.

- Turning to the left: The outside rearview mirror on the driver seat side is selected.
- Turning to the right: The outside rearview mirror on the front passenger seat side is selected.

Adjusting the angle of the outside rearview mirror

Adjust the angle of the mirror according to the driver's view by moving the Control button (2) up, down, left, or right.



Warning

- Do not tint the driver seat and the front passenger seat windows. Doing so may make the outside rearview mirror less visible while driving at night, causing an accident.



Caution

- The outside rearview mirror can be folded or unfolded for a certain period of time after the vehicle is turned off.
- Do not operate the mirror excessively after the vehicle is turned off. Doing so may cause depletion of the battery.
- Do not operate the mirror more than needed. When the mirror reaches its maximum adjustment angle, its movement stops, but the motor operates continuously while the switch is being pressed, causing the motor to malfunction.

- Do not operate the outside rearview mirror using hands instead of the motor switch. Doing so may cause the mirror and relevant devices to malfunction.
- Do not spray high pressure water directly onto the mirror while washing the vehicle. The outside rearview mirror operates electrically, so it may not operate normally due to an electrical device failure.
- If the mirror is frozen and does not move during winter, do not adjust it forcibly. Adjust the mirror carefully after removing ice by using deicing spray or soaking a soft cloth or sponge in warm water and wiping the frozen part with it.
- Do not scrape ice off even if the surface of the mirror is frozen during winter. Doing so may damage the surface of the mirror.

Interior mirror

The inside rearview mirror can be adjusted up, down or side ways to obtain the best rear view.

ECM room mirror*

The ECM (Electronic Chromic Mirror) room mirror detects a light from a following vehicle automatically through the light sensor and lowers the reflection rate of the mirror to prevent glare for the driver.

- To adjust the angle of the interior mirror, hold and move the body of the mirror with your hand up, down, left and right to obtain the best rear view.



Warning

- Be sure to finish adjusting the mirror before driving.
- Never adjust the mirror while driving. Doing so may distract the driver, causing an accident.
- If the interior mirror is broken, the electrolyte inside the mirror may flow out. Be careful not to allow this electrolyte come into contact with your skin or eyes. If the electrolyte comes into contact with your eyes, wash it with water immediately and consult a doctor.

Caution

In any of the following cases, the automatic anti-glare function of the ECM room mirror may not operate.

- If the head light of a following vehicle is not beamed directly to the light detection sensor
- When the rear window is tinted darker
- If the SBW (shift by wire) is in the R (Reverse) position

At this time, the automatic anti-glare function is suspended to enable easy identification of an object.

Manual type inside rearview mirror



The inside rearview mirror can be adjusted up, down or side ways to obtain the best view by holding the body of the mirror with your hand.

Manual Day/Night Adjustment (A)

You can manually adjust the rearview mirror by pushing or pulling its adjusting lever to avoid blindness at night due to other vehicles behind you.

Warning

- For your safety, adjust the mirror before driving off the vehicle.

Caution

- When you are not able to see the back of your vehicle at night, adjust the rearview mirror by holding the mirror body and pushing or pulling it to a desired angle so that you can secure a clear rear view.

Heater and air conditioner



- 1 Heater and air conditioner controller
- 2 Air outlet (middle of the front seats)
- 3 Air outlet (both sides of the front seats)
- 4 Side air outlet of defroster
- 5 Central air outlet of defroster

- 6 Solar radiation detection sensor
- 7 Windshield fog detection sensor
- 8 Interior temperature sensor
- 9 Rear seat foot duct (bottom of the front seat upholstery)

Adjusting the direction of air distribution and blocking the air distribution

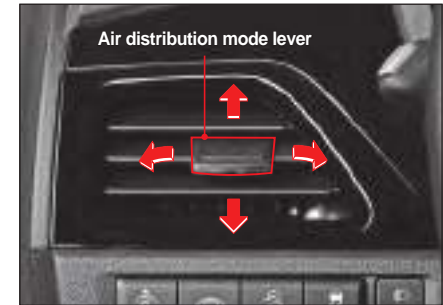

- Adjust air distribution
You can adjust the direction of air distribution by moving the air distribution mode lever up, down, left and right.
- Open and close air vents
If you push the air distribution mode lever all the way to the closing (☒) direction, the air vent closes and the air does not come out. If you put it in the opening (≡) direction, air comes out.

Caution

- Do not attach a cup holder or other devices to the air guide pin of the air outlet. Doing so may damage the air guide pin or other relevant devices.

Cautions for using the heater and air conditioner

Replacing A/C refrigerant/oil

Be sure to replace the A/C refrigerant and oil with the products that meets the specified standard and capacity. Failure to do so may damage the air conditioner system.

Classification	Specifications	
	H/P	Non H/P
Standard	R-1234yf	
Refrigerant capacity	750 ± 30g	550 ± 30g
Oil capacity	170 ± 10cc (RB 100EV-01)	

Warning

- While driving, select the fresh air mode if possible or open the window and ventilate frequently to allow fresh air to flow in. Failure to do so may make the air inside the vehicle to be stuffy, causing headache or dizziness.
- Caution should be taken that if exhaust gas flows in, it may cause carbon monoxide poisoning.
- When you drive in an area where dust and smoke may flow in, pass the area using the recirculation mode and switch it to fresh air mode for ventilation.
- Do not sleep or stay inside the vehicle for a long period of time while operating the air conditioner or the heater with the doors and the windows closed during midsummer or midwinter. Doing so may cause suffocation due to lack of oxygen inside the vehicle.
- Never leave an infant, a small child or an elderly alone in the vehicle even for a short period of time during midsummer. The temperature inside the vehicle may increase, causing risks such as suffocation.
- Refrigerant is flammable which can cause the fire by the gas leakage or static, so be very careful when handling Refrigerant (R-1234yf).

Caution

- Before driving the vehicle, open all windows to ventilate the air inside the vehicle properly for the health of occupants and a pleasant indoor environment. Especially, if the vehicle has been parked on a place exposed to direct sunlight for a long period of time, the temperature inside the vehicle may have increased, causing volatile organic compounds that are harmful to human body to be emitted.
- Do not start the engine while electrical devices with high electrical load such as the air conditioner and fan are running. In such case, it may be difficult to start the vehicle.
- When you drive up on a long sloping road continuously, turn on and off the air conditioner every 3 to 5 minutes.
- Do not mix POE-based refrigeration oil for E-compressor with PAG-based refrigeration oil. Doing so will cause corrosion of the metal material inside the E-compressor.



Caution

- Be sure to operate the air conditioner at a low speed if you use the air conditioner again after it is not used for a while. If the air conditioner is not used for a long period of time, the oil in the compressor is not circulated, causing a failure.
- When you use the air conditioner after it is not used for a long period of time, there may be a smell from the air outlet. In such case, open the window and operate the air conditioner for 20 to 30 minutes to eliminate the smell.
- Do not turn off the vehicle suddenly while operating the air conditioner. The fan motor stops suddenly and cold or warm air in the duct is condensed in the pipe without being emitted to the outside, creating a bad smell. Before turning off the vehicle, turn off the air conditioner and emit air in the duct for 2 to 3 minutes in the fresh air mode.
- Do not operate the air conditioner for a long period of time while stopping the vehicle. Doing so may overheat the engine, causing a failure.
- If the motor vehicle is not running, do not operate the fan for a long period of time. Doing so may cause depletion of the battery.



Caution

- Operate the air conditioner once a week in seasons other than winter to circulate the oil in the air conditioner compressor and relevant parts smoothly. This helps you to maintain the air conditioner in its best condition.

Heater and A/C controller

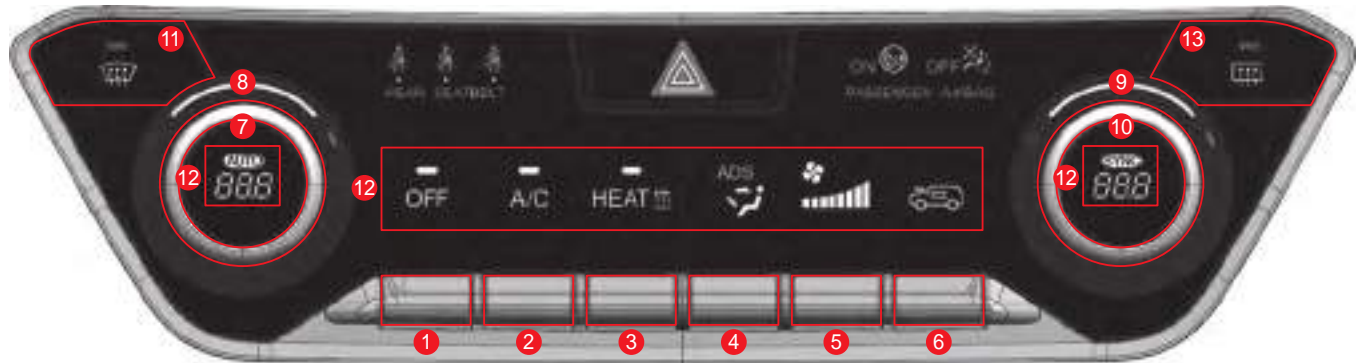

- ① ON/OFF switch
- ② A/C switch
- ③ Heating mode switch
- ④ Air distribution mode switch
- ⑤ Fan Speed Control Switch
- ⑥ Air source selection switch
- ⑦ AUTO switch
- ⑧ Driver side temperature control dial
- ⑨ Passenger side temperature control dial
- ⑩ SYNC switch (to sync with driver side set temperature)
- ⑪ Defroster switch
- ⑫ Operation indicator display
- ⑬ Glass heater switch

Turning on/off the heater and the air conditioner

- To turn on the heater and the air conditioner, press the ON/OFF switch (1).
 - The operation indicator is turned off.
 - The heater and the air conditioner turn on with the previous operation status maintained.
- To turn off the heater and the air conditioner, press the ON/OFF switch (1) again.
 - The operation indicator is turned on.

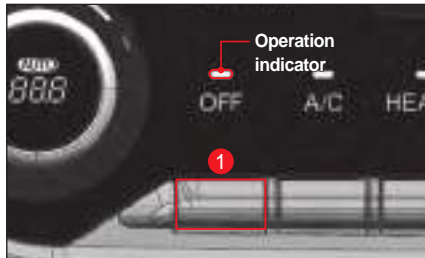

Notice

- When you rotate the temperature control dial or press the air distribution switch or air source selection switch with the OFF indicator turned on, you can set or change each function but the air blower remains off.

Adjusting the temperature of the driver seat and the front passenger seat

You can adjust the set temperature by turning the driver's / passenger's temperature control dials (1)(2). You can set the temperature based on the driver's seat or adjust the driver's and passenger's set temperature individually.

- With the SYNC operation indicator (3) on, the set temperature of the driver seat and the front passenger seat is changed simultaneously.
- The set temperature can be adjusted by 0.5°C when you operate the temperature control dial.



Notice

- When you press the AUTO switch in the manual mode, the mode changes to the AUTO mode, and each mode is controlled automatically according to the set temperature.

Adjusting the temperature of the driver seat and the front passenger seat (independent operation)

The set temperature of the driver seat and the front passenger seat can be adjusted independently.

- Until the SYNC operation indicator (3) is turned off, press the SYNC switch (4) or the Front passenger seat temperature control dial (2) once or repeatedly.

Synchronizing based on the driver seat set temperature (SYNC)

The set temperature of the driver seat applies to the set temperature of the front passenger seat,

- Until the SYNC operation indicator (3) is turned on, press the SYNC switch (4) once or repeatedly.

Notice

- Air conditioner ON/OFF, direction of air distribution, recirculation mode or fresh air mode are set automatically according to the set temperature of the driver seat.
 - If the set temperature is a low temperature (LO): Air conditioner ON, direction of air distribution towards face and recirculation mode
 - If the set temperature is a high temperature (HI): to control as 29.5°C of the set temperature

Auto mode

Operate as follows while the vehicle is running.

- Press the AUTO switch (1).
 - In auto mode: **AUTO**
 - In manual mode: **AUTO**
- Turn the temperature control dial (2) to set the desired indoor temperature.





Notice

- When the AUTO mode is activated, the fan speed and direction of air distribution are adjusted automatically according to the set temperature, indoor temperature and air temperature.
- Pressing the air source selection switch, fan speed dial, air distribution mode switch, A/C switch, or defroster switch in auto mode deactivates the auto mode and the system enters the manual mode.

Manual mode

Operate as follows while the vehicle is running.

- Press the ON/OFF switch (1).
- Turn the temperature control dial (2) to set the desired indoor temperature.
 - The current set temperature is displayed on the operation indicator.
- Press the fan speed switch (3) up (fan speed up) or down (fan speed down) to set the amount of air flow.
 - The current fan speed is displayed on the operation indicator.
- Press the air distribution mode switch (4) to set the desired air flow direction.
- Press the air source selection switch (5) to switch between the fresh air and recirculation modes.
 - Recirculation mode: 
 - Fresh air mode: 
- If you wish to use the air conditioner, press the Air conditioner switch (6).

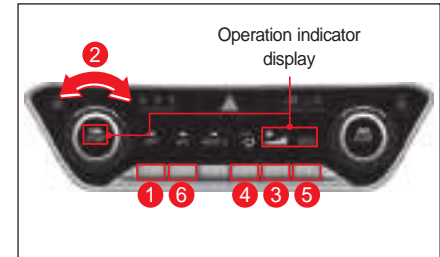

Warning

- Do not use the recirculation mode longer than is needed. Doing so may cause headache or drowsiness due to lack of oxygen inside the vehicle. Also, moisture may occur on the window, impairing safe visibility and may result in an accident.
- Be careful not to allow exhaust gas to flow into the inside of the vehicle. Doing so may cause carbon monoxide poisoning.
- Pass an area where dust and smoke may flow in using the recirculation mode. After that, switch the mode to the fresh air mode for ventilation.

Notice

- When you press the AUTO switch in the manual mode, the mode changes to the AUTO mode, and each mode is controlled automatically according to the set temperature.

Selecting the direction of air distribution

Press the air distribution mode switch (2) upwards or downwards to set the desired air flow direction.

- The current air flow direction is displayed on the operation display panel.

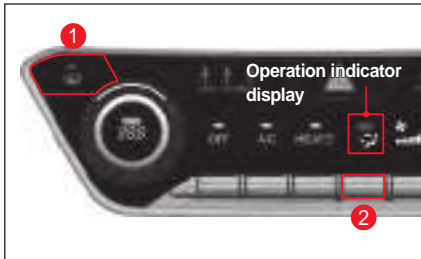

1 When defroster switch pressed



Air distribution towards the windshield and door windows

When you press the Defrost and defog switch, the mode is switched to the fresh air mode automatically and the air conditioner is turned on.

2 When air distribution mode switch pressed

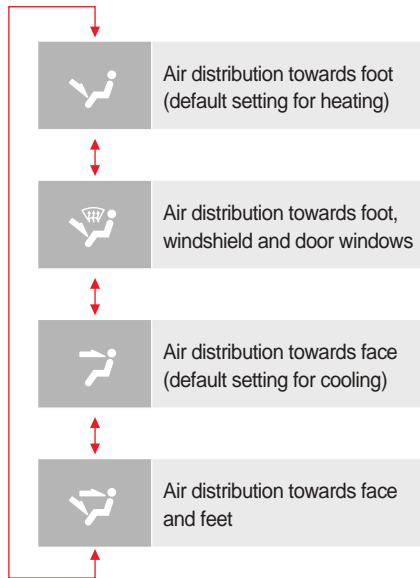

Notice

- If the direction of air distribution is set to feet, a little bit of air comes out towards the windshield and door glass to prevent the occurrence of moisture on the windshield.

Operating the glass heater

If the glass is covered with frost or mist, you can remove the frost or mist by operating the glass heater.

- To operate the glass heater, press the Glass heater switch. The operation indicator turns on and the glass heater operates for approximately 12 minutes.
- To stop the glass heater operation, press the Glass heater switch again. The operation indicator turns off and the glass heater operation stops.

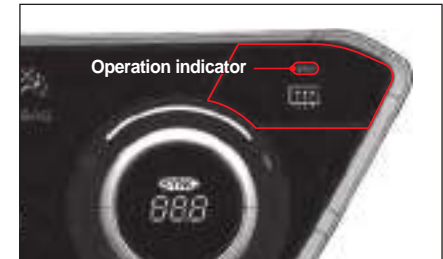

Rear window heater



Outside rearview mirror heater

Notice

- The glass heater only operates while the vehicle is running.
- When you operate the glass heater, rear glass and outside rearview mirror operate at the same time.
- To operate the glass heater again within 10 minutes after it is operated for 12 minutes, the glass heater operates only for approximately 6 minutes.

Removing moisture on the glass

- 1 Press the Defrost and defog switch (1).
 - The operation indicator turns on.
- 2 Press the fan speed switch (2) up (fan speed up) or down (fan speed down) to set the amount of air flow.
 - The current fan speed is displayed on the operation display panel.
 - To remove moisture on the glass quickly, set the fan speed to high.
 - To remove frost or mist on the outside surface of the glass, set the temperature to high.

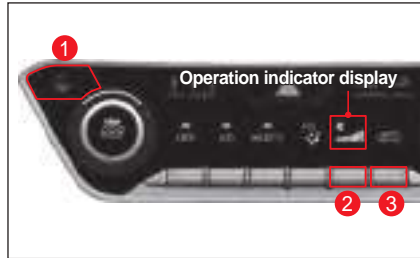

Warning

- If it rains or the humidity is high, switch the recirculation/fresh air switch to the fresh air mode and set the direction of air distribution to the windshield. If it rains or the humidity is high, moisture may occur on the windshield as well as other windows even if the air conditioner is turned on. This may lead to poor front, side and rear visibility that can result in a very dangerous situation.

Caution

- If the defrost and defog function is turned on and the direction of air distribution is set to feet or feet and the windshield, do not operate the air conditioner excessively. Doing so may cause moisture to occur on the outside surface of the windshield due to a temperature difference between the inside and outside of the vehicle. In such case, quickly remove the moisture on the outside surface of the windshield using the wiper and switch the direction of air distribution to the face to reduce the moisture occurrence on the outside surface of the windshield.
- Be sure to remove foreign materials (snow, fallen leaves, etc.) from the air inlet during winter and summer to prevent the occurrence of moisture on the glass.

Notice

- When you press the Defrost and defog switch (1), the air conditioner is activated automatically and the fresh air mode and level 1 fan speed or faster are set. When you press the switch again, the system returns to its original condition.
- In order to prevent moisture occurrence on the glass generally, it is recommended to set the recirculation/fresh air switch (3) to the fresh air mode.

Auto defogger system

The auto defogger system is an auxiliary device that removes mist from the inside surface of the windshield automatically when it is detected, enabling safe driving.

Activating/deactivating the auto defogger system

- To activate the auto defogger system, press the ON/OFF switch (2) for 5 times within 3 seconds with the Defrost and defog switch (1) pressed.
 - The operation indicator of the auto defogger system (3) blinks for 3 seconds.
- To deactivate the auto defogger system, press the ON/OFF switch (2) for 5 times within 3 seconds with the Defrost and defog switch (1) pressed.
 - The operation indicator of the Defrost and defog switch (4) blinks for 3 seconds.

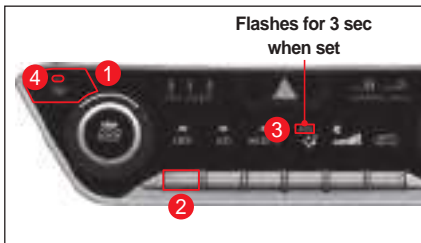

Operation levels of auto defogger system

As the humidity on the inside surface of windshield becomes higher, the auto defogger system operates at a high level. For example, if the humidity cannot be controlled by switching to the fresh air mode that is level 1, the operation is carried out from level 2 to level 4 in consecutive order to control the humidity.

- Level 1 - Switch to the fresh air mode
- Level 2 - Air conditioner ON
- Level 3 - Air distribution towards the windshield
- Level 4 - Increase the fan speed towards the windshield



Warning

- Do not switch the mode to the recirculation mode while the auto defogger system is operating. Doing so may decrease the moisture removal effect, impairing safe visibility and may result in an accident.
- Do not remove the sensor cover on top of the windshield forcibly. Doing so may damage the auto fog detection sensor.

Heating mode switch

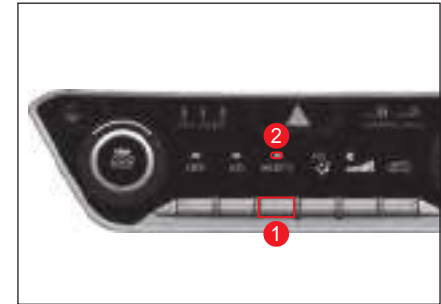

To use the heating system, press the heating mode switch (1). Then the operation indicator (2) shall be turned on and the heater temperature can be adjusted according to the setting temperature.

To turn off the heating system, press the heating mode switch (1) under the state of the operation indicator (2) turned on.

Solar radiation sensor



The solar radiation sensor is mounted on the top of the instrument panel (IP). It detects solar radiation and automatically adjusts the vehicle interior temperature according to the amount of solar radiation, when the user selects "AUTO" on the heater and air conditioner controller.



Caution

- Do not place any object on the top of the instrument panel. This can prevent the solar radiation sensor from functioning properly.

Steering wheel

Adjusting the height/length of the steering wheel

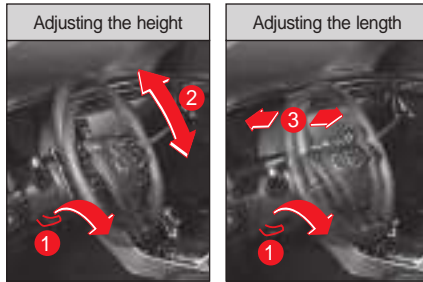

- 1 Push down the steering wheel telescoping/tilt control lever (1).
- 2 Adjust the position of the steering wheel upwards and downwards (2) and forwards and backwards (3) properly.
- 3 Lift the steering wheel telescoping/tilt control lever (1) up.

After adjusting the steering wheel, check that the steering wheel is secured firmly.

Warning

- Check that the steering wheel is secured firmly before driving.
- Do not adjust the steering wheel while driving. Doing so may cause a serious accident.

Caution

- Do not turn the steering wheel left or right to the end and maintain such position for 10 seconds or more with the vehicle started. Doing so may damage the power steering system due to overload.
- In winter (-10°C or below), starting off the vehicle immediately after starting the engine while the power steering fluid is cold can sometimes cause a momentary delay in the power steering, so be sure to let the engine idle properly before starting.

Steering wheel heater*



- To activate the steering wheel heater, press the steering wheel heater switch while the vehicle is running.
The operation indicator on the instrument cluster turns on.

- To deactivate the Steering wheel heater, press the Steering wheel heater switch again.
The operation indicator on the instrument cluster turns off.

Caution

- Do not attach an assist knob to the steering wheel. Doing so may damage the heater in the steering wheel and impede safe steering.

Notice

- The status of the Steering wheel heater switch is maintained even if the vehicle is turned off and on again.

Horn

Warning horn is sounded while the horn is being pressed.

Caution

- Using the horn may startle pedestrians. Use it carefully only when it is necessary.

Infotainment system

Smart audio*

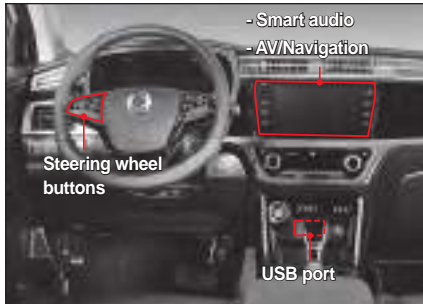

! Caution

- The Android auto and Car Play in the vehicle may not be supported or some functions may not be compatible according to the specification or characteristics of the relevant device.
- The connection of the relevant devices to the vehicle may not be supported or some functions may not be compatible according to the specification or characteristics of the relevant video player, MP3 player.
- The method of use may be different or the connection to the vehicle may not be supported according to the specification or characteristics of the relevant Bluetooth device.

! Caution

- Some USB storage devices and SD cards may not be compatible with the relevant device in the vehicle. Using a non-compatible memory card may damage the relevant device in the vehicle, memory card or data saved in the memory card.

Notice

- For detailed explanation regarding the infotainment system in the vehicle including smart audio, AV/Navigation and slots for multimedia, refer to the owner's manual provided separately.
- If you wish to connect an external device to the infotainment system in the vehicle including smart audio, AV/Navigation and slots for multimedia, refer to the owner's manual of the relevant device for how to connect and use such device.

! Warning

- The rear camera screen does not work during software update. Always stop the vehicle to update the software and do not drive the vehicle until the update is completed.
- Be careful when reversing since the rear obstacle may be hidden by the warning messages and parking guide lines if the rear camera system is activated.
- The smart audio has an 8-inch touchscreen and four buttons, and can be operated with the buttons on the steering wheel.
- The USB port allows you to connect external devices to the multimedia socket.
- Including Bluetooth and rear view camera, the following apps are supported: Android Auto (for Android device) and CarPlay (for iOS device). (iOS devices can be charged through the USB port.)
- The operation information of the smart audio is displayed on the instrument cluster.



Warning

- The rear camera screen does not work during software update.
- Always stop the vehicle to update the software.
- Rear obstructions may be obscured by warning message or parking guide lines during rear camera operation, resulting in an accident when reversing.



Caution

- During driving, video is not supported and only audio is supported for safety. When the vehicle stops, video is supported again.
- Do not use the audio system for a long period of time with the vehicle not started. Doing so may cause depletion of the battery in the vehicle.

AV/Navigation*

- The AV / navigation can be operated with the 12.3-inch electrostatic touch panel (including the 9.0-inch monitor) and the buttons on the steering wheel (voice recognition supported).
- The USB port (iPod, iPhone, iPad) allows you to connect external devices to the multimedia socket.
- It shows the control status according to the operation of the heater and the air conditioner to improve the visual comfort of the driver.
 - The heater and the air conditioner can not be controlled by screen touch.
- Supported features include: Bluetooth, micro SD card (navigation), rear view camera as well as Android Auto (for Android device) and CarPlay (for iOS device). (iOS devices can be charged through the USB port.)
- Some operation information of AV / navigation is displayed on the instrument cluster.



Warning

- Be sure to use the navigation and video-related functions after stopping or parking the vehicle at a safe place for safe driving.



Caution

- Do not use the AV/navigation system for a long period of time with the vehicle not started. Doing so may cause depletion of the battery in the vehicle.



Warning

- The rear camera screen does not work during software update. Always stop the vehicle to update the software and do not drive the vehicle until the update is completed.
- Be careful when reversing since the rear obstacle may be hidden by the warning messages and parking guide lines if the rear camera system is activated.

Slots for multimedia



With the USB port, you can connect the external music / video playback devices such as USB storage and iPod to the vehicle.

Caution

- Some USB storage and external music / video playback devices may not be played through the USB port.

Operating from the steering wheel



- 1 Bluetooth hands-free button
- 2 Volume control lever
- 3 Mute button
- 4 Media search (SEEK) lever
- 5 Mode selection button
- 6 Voice recognition button

Voice recognition function

This convenient function allows you to use various functions of the infotainment system through voice recognition.

+ VOL - Controlling the volume

Raises or lowers the volume.

Bluetooth hands-free

You can connect and use your mobile phone in the vehicle through Bluetooth.

Notice

- For detailed explanation regarding the Bluetooth hands-free, refer to the owner's manual provided separately.

Mute

- Tapping the Mute button with the audio system turned on turns off the voice output. Tapping it again turns on the voice output.
- Pressing and holding down the Mute button with the audio system turned on turns off the audio system.

MODE Selecting the mode

- The AV mode changes each time you press the Mode button.
- Tapping the Mode button with the AV system turned off, turns on the AV system.

SEEK Searching for media (SEEK)

Classification	Tap up/down the SEEK lever	Push up/down and hold the SEEK lever
When playing on the media screen	Plays the previous/next track	Moves to the previous/next list of tracks (The current playback is maintained)
When playing on a screen other than the media screen		
When listening in the radio screen	Moves to the previous/next saved channel	Moves to the previous/next available radio frequency
When listening in screens other than the radio screen		

Notice

- Since some media devices may operate differently, please refer to the user manual of the corresponding device.

Antenna (GPS, radio, DAB (EU), GSM (E-call))



When the audio system is turned on, the antenna receives the following radio waves.

- Smart audio: GPS, radio, DAB, GSM
- AV/Navigation: GPS, radio, DAB, GSM

Power socket

Power socket (front side of center console)



Power socket (rear side of center console)
(without AC inverter)



Power socket (left bottom of luggage compartment)

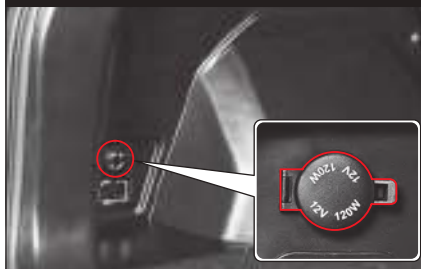

The power socket (12 V, 120 W) is provided in the vehicle to enable the use of a separate electrical device.

Warning

- Caution should be taken that inserting a finger into the power socket may cause injury such as an electric shock.
- Be sure to use a separate electrical device after connecting it to the power socket. Modifying the wires in the vehicle arbitrarily and using an electrical device may cause an accident such as a fire.
- Observe the rated capacity of the power socket (12 V, 120 W). Failure to do so may cause the power socket and the connected device to malfunction or fail.
- Caution should be taken that using the power socket with the vehicle turned off may cause depletion of the battery.
- If the power socket is not used, be sure to close the power socket cover. Failure to do so may let foreign material or liquid such as water enter into the power socket, causing damage to the device as well as an electric shock.

AC inverter*

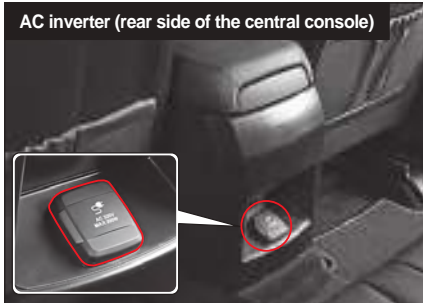

The AC inverter is a convenient device that converts the DC 12 V electricity provided by the vehicle into the 220V (200W) [115V (150W)] that is the electricity for homes, allowing you to connect and use a simple electrical appliance such as the laptop computer, smartphone, mobile TV, lighting equipment, battery charger, etc.

- Operate the AC inverter, open the AC inverter socket cover and connect a desired electric product.

Operating the AC inverter

- With the vehicle turned on or the START/STOP switch in the ON status, press the AC inverter operation switch. When operation indicator turns on and the 220V (115V) voltage is outputted.

When you press the switch again, the operation indicator turns off and the operation of the AC inverter stops.

- The status of the AC inverter operation switch is maintained even if the vehicle is turned off and on again.



Warning

Not paying attention while using the AC inverter is very dangerous since its electricity standard is for home use. In particular, always follow the precautions below.

- **Do not use an electrical appliance (electric kettle, toaster, iron, etc.). Doing so may cause a fire.**
- **Do not insert any foreign material into the AC inverter socket or touch it with hands. Doing so may cause an electric shock or fire.**
- **Do not allow a young child to touch the AC inverter socket. Doing so may cause an electric shock or fire.**
- **Do not touch or use the inverter socket with wet hands. Doing so may cause an electric shock, resulting in a serious injury.**
- **Do not use the AC inverter and the connected device for a long period of time in a place that is sealed and not ventilated. Doing so may cause exhaust gas poisoning.**



Caution

- Do not operate the AC inverter or connect an electrical appliance to the AC inverter for a long period when the vehicle is turned off. Doing so may cause depletion of the battery.
- Even an appliance indicating the power consumption less than the rated capacity of the AC inverter may not operate normally in any of the following cases.
 - A home appliance requiring high power at the time of initial operation
 - A measuring equipment that needs to process accurate data
 - A device that requires a stable power supply (Notebook)
- Do not connect an electrical appliance that requires power consumption higher than [115V(150W)] to the AC inverter. Doing so may cause a fire due to electric overload.
- Do not connect some inadequate electrical devices that generate excessive electromagnetic wave noises to the AC inverter. Doing so may cause a noise to audio or AV system and electrical devices in the vehicle may operate abnormally.
- Do not connect two or more electrical devices or components to the AC inverter at the same time. Doing so may cause a fire due to electric overload.



Caution

- Do not connect a defective electrical device to the AC inverter. Doing so may damage the AC inverter and the electrical system in the vehicle.
- When the input voltage of the AC inverter decreases, the operation indicator blinks and the AC inverter is turned off automatically. This is to protect the AC inverter, electrical system in the vehicle and the connected device. When the input voltage of the AC inverter increases, the AC inverter operates normally again.
- Do not place the smart key near the AC inverter. Doing so may prevent the smart key from operating smoothly due to the electromagnetic wave from the AC inverter.
- If you are not using the AC inverter, turn off the AC inverter operation switch and close the socket cover.

Indoor convenient equipment

Sun visor and card holder (driver seat)

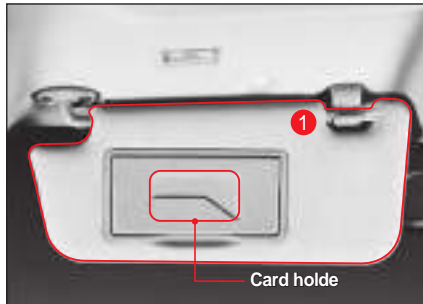

Sun visor

You can block out the sun from the front or the sides by lowering the sun visor (1).

- You can adjust the position of the sun visor (2) for blocking out the sun from the sides.

Card holder

The card holder is provided in the inside cover of the sun visor. It is convenient to store a motorway toll ticket or a card.

⚠ Caution

- Adjusting the sun visor or using the card holder or mirror while driving may lead to careless driving or block the driver's vision, resulting in an accident.
- Adjust or use the sun visor and card holder after stopping or parking the vehicle.

Mirror and lamp

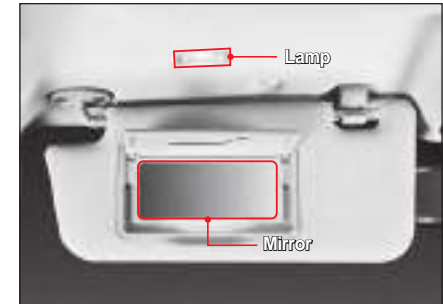

- You can use the mirror by lowering the sun visor and lifting up the cover.
- When you lift up the mirror cover, the lighting lamp turns on.

⚠ Caution

- Be sure to close the mirror cover after using the sun visor mirror. Failure to do so may cause the sun visor lamp to stay on and the battery may be depleted. Also, an open mirror cover may cause injury.

Grip handle/coat hanger



- The grip handle is installed on the side ceiling of the driver seat, front passenger seat and rear seats (head lining).
- The coat hanger is included in the grip handle on the ceiling of the rear seats.

Warning

- Do not hang articles other than cloth on the coat hanger. Doing so may cause the side air bag to operate at the time of an impact of an accident, resulting in damage to the vehicle as well as the injury or death of an indoor occupant.

Caution

- Do not hang a heavy cloth on the coat hanger. Doing so may damage the coat hanger and the ceiling (head lining).

Storage unit

Front seat/rear seat cup holder

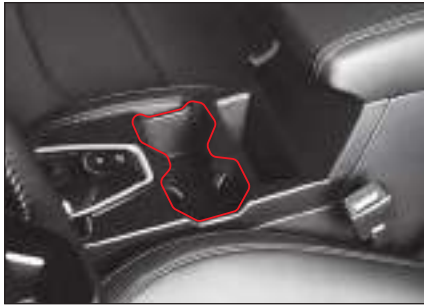

The cup holder is provided in front of the central console section.



There is a cup holder when you lower the rear seat armrest.



Caution

- Caution should be taken that hot liquid in the cup may overflow or spill, causing a burn.
- Pay particular attention while driving since the cup may fall down or the liquid in the cup may spill over.
- Caution should be taken that if liquid in the cup spills over into the switches or operation buttons, it may cause trouble to the system functions.

Front storage (W/O WPC)

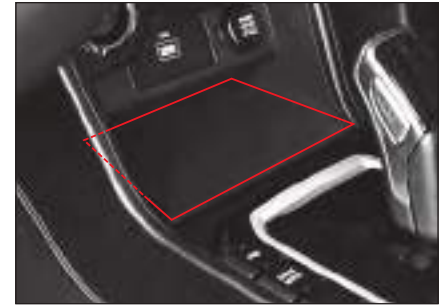

The front storage is provided near the SBW (shift by wire). Use it for storing a small article.



Caution

- Dropping or extruding objects placed in the front compartment may interfere with the movement of the electronic shift lever.

Notice

- The front storage only applies to the vehicles without wireless charging system (WPC).

Sunglass holder



Press the center of the cover to open the sunglasses holder.

Push it up to close.



Caution

- Do not drive without closing the sunglasses holder completely after using it. An open sunglasses holder may obstruct you from identifying a situation in the rear through the rearview mirror. It can also cause injury in the event of an accident of sudden stopping.

Glove box

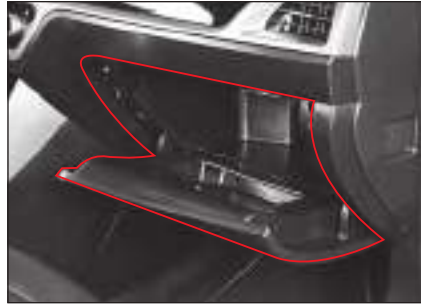

The glove box can be used for storing documents related to the vehicle registration or articles used in the vehicle conveniently.

- Pull on the glove box lever to open the glove box.



Caution

- Leaving the glove box opened may cause injury to an occupant in the event of an accident or sudden braking. Close the glove box while driving.
- Do not store any flammable materials or a cigarette lighter, etc. in the glove box, console or inside the vehicle. Doing so may cause an explosion during midsummer or the air inside the vehicle is heated.

Notice

- The lamp in the glove box illuminates when opening the glove box with the light switch in the headlamp/tail lamp ON position.

Console



- The front seat console can conveniently store things for passengers in the front seats.
- It can slide forward and backward to enhance the driver's comfort.



Caution

- Do not store any valuable article on the console for preventing theft.
- Do not store an article that can be damaged easily or creates noise on the console as it may move while driving.
- Do not store any flammable materials or a cigarette lighter, etc. in the console, the glove box, or indoor. Doing so may cause an explosion during midsummer or when the air inside the vehicle is heated.

Door map pocket

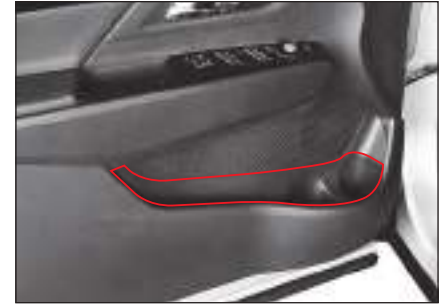

The pocket (bottle tray) where books, magazines, water bottles or beverages can be stored is provided.

Seat backrest pocket



It can be used conveniently for storing magazines or newspapers.



Caution

- Do not store scissors, knives, or other objects with an improper size in the seat backrest pocket. Doing so may cause personal injury in the event of sudden braking or a vehicle collision.

Wireless Phone Charger System*

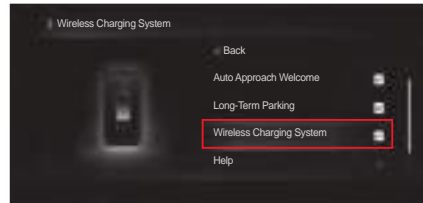
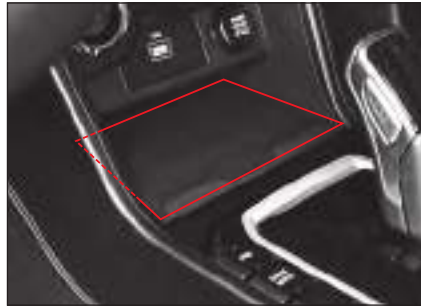

The wireless phone charger system is a device that wirelessly charges the electronic devices (such as mobile phone) that conforms to Qi standard, which is located in front of the transmission selector lever.

The wireless phone charging is available only when the driver sets (ticks) the wireless charging system under User Settings menu in the instrument cluster.

To Charge Phone

- 1 Close all the vehicle doors and start the vehicle.
- 2 Set (Tick) the wireless charging system under User Settings (Vehicle setting → Convenience → Wireless charging system) menu in the instrument cluster.
- 3 Remove everything including the smart key on the wireless charging pad. If there is anything other than the phone on the charging pad, it may not charge.
- 4 Place the wireless charging enabled phone in the center of the charging pad.
- 5 When charging begins, the following pop-up display appears on the instrument cluster for approximately 5 seconds: (Depending on the instrument panel display information, the status display may be delayed.)
 - Phone charging in progress
 - Phone charging completed
 - Phone charging fault

☞ Refer to "Getting your vehicle started" (p.4-3)



Caution

- If any phone is on the wireless charging pad after the ignition is off while the wireless phone charger is operating, a reminder message “The phone is on the wireless phone charger.” is displayed on the instrument cluster. After turning off the ignition, be sure to leave the vehicle with your phone.
- The reminder function is turned on when the ignition switch is changed from the ON position to the ACC or OFF position. However, it does not work when changing the ignition switch from the OFF position to ACC position.

Notice

- The wireless phone charger system can be used to charge the mobile phones only that conform to the Qi standard. Whether your phone meets the Qi standard can be checked with a separate accessory cover or phone manufacturer.
- The charging function can be turned on (tick) or off (untick) under the User Settings menu in the instrument cluster.



Caution

- If the temperature or voltage inside the wireless phone charger system exceeds a certain value, the charging function is temporarily stopped to protect the phone and the system.
- The farther your phone is from the center of the charging pad, the less charging efficiency the phone may have.
- Be sure to position your phone in the center of the wireless charging pad.
- Depending on the type of mobile phone cover, charging may not work or a lot of heat may be generated. (e.g., LED cover, thick cover)
- Charging may stop if the mobile phone is not securely pressed against the wireless charging pad.
- If there are magnetic products (credit card, check card, bankbook, ticket and etc.) around the wireless phone charger, its information may be damaged.
- If a metal object is on the wireless charging pad, charging does not work or may stop and a metal object may become hot during charging.
- The mobile phone which is not Qi standard certified may not be charged.



Caution

- Charging stops temporarily when the smart key detection function is activated. (e.g., when starting the vehicle, immediately after the door is open / closed)
- If the terminal that complies with the Qi standard does not provide a full charge information, charging may continue to generate heat.
- If more than one terminal is placed, charging does not work.
- On some manufacturers' phones, the relevant information may not appear on the instrument cluster.
- For the mobile phones that do not have a built-in wireless charging feature, you have to equip with separate accessories individually.
- If you place a phone or metallic object that does not have wireless charging on the charging pad, you may hear some noise. (The noise is a normal operation sound generated in the process of determining whether the mobile phone can be charged wirelessly, which does not affect the mobile phone and the vehicle.)

Additional equipment in the luggage compartment*

Luggage upper cover

The luggage upper cover is used for covering luggage so that it cannot be seen.

Installing the luggage upper cover

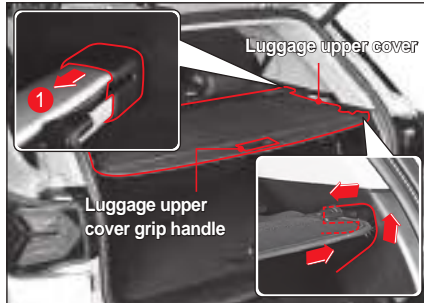

- 1 Fit both ends of the luggage upper cover into the groove on the vehicle body by pressing them in the arrow direction (1).
- 2 Pull the luggage upper cover grip handle and fit it into the groove on the vehicle body.

Adjusting the position of the luggage upper cover



The luggage upper cover can be fixed at the position of one-tier or two-tier according to the angle adjustment level of the rear seat backrest.

! Caution

- Do not place any article on top of the luggage upper cover. Doing so may cause the article to bounce forward, injuring an occupant or damaging the luggage upper cover.
- Do not press the top of the luggage upper cover forcibly. Doing so may damage the luggage upper cover.
- Do not relocate the luggage upper cover when it is pulled out. Doing so may damage the luggage upper cover.
- Do not forcibly recline the rear seat backrest from level 1 to level 2 with the luggage upper cover installed in the 1st position. It may damage the luggage upper cover.

How to store luggage upper cover

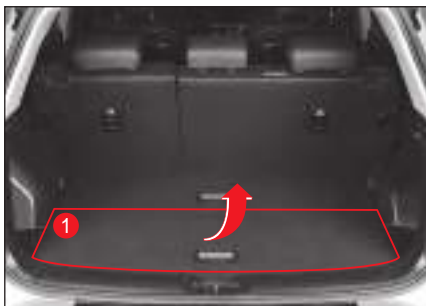

- 1 Lift out the luggage compartment board (1) in the direction of the arrow.



- 2 Lift out the luggage compartment board LH/ RH side covers (2).



- 3 Pull the left / right end (3) of the luggage compartment upper cover inward and fix it in the groove. The other side is also performed in the same way.



- 4 Make sure that the luggage upper cover is secured firmly.

Luggage compartment board



The luggage compartment board is divided into two.

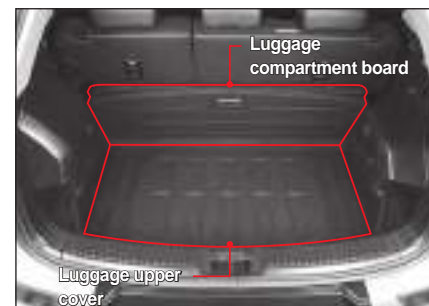

The luggage compartment board can be stored as shown in the picture and the luggage compartment cover is located at the bottom of it.

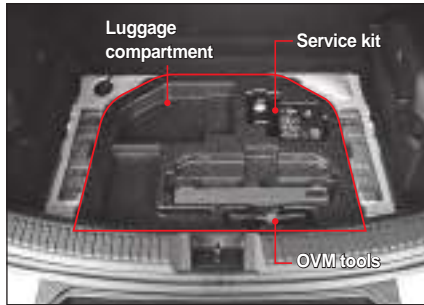

The luggage compartment contains a service kit, a warning triangle, and OVM tools.

Luggage net

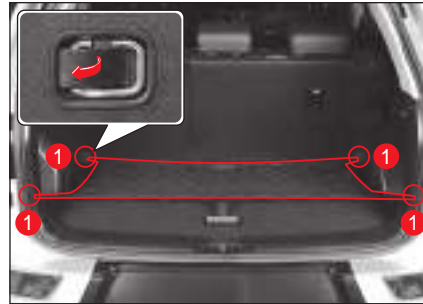

The luggage net prevents an article loaded into the luggage compartment from moving.

- When installing the luggage net, take out the hook (1) in the direction of the arrow and hook the luggage net to fix it.

Caution

- Do not attempt to fix an excessively bulky or heavy article with the luggage net. Doing so may cause the article to fall out of the luggage net or damage the luggage net.
- Hold the luggage net firmly with your hands during fixing. Failure to do so may cause injury due to the repulsive force of the luggage net.
- Do not use the luggage net if the elastic part of the luggage net including its fixing part is worn out or damaged.

Roof rack*

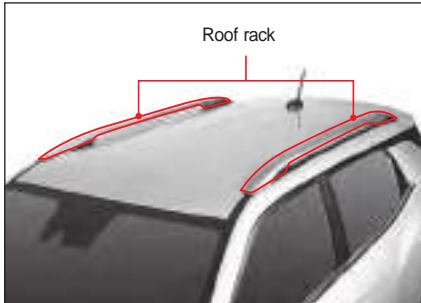

The luggage can be loaded onto the top of the vehicle roof using the roof rack.

Also, leisure sporting goods such as a bicycle, snowboard and skis by installing a separate carrier on the roof rack.

- The maximum loading capacity of the roof rack is 100 kg (220 lbs).

Warning

- The luggage loaded onto the roof rack should not exceed the maximum loading capacity. The luggage loaded onto the roof rack should not stick out of the roof. If the maximum loading capacity is exceeded or the luggage sticks out of the roof rack, the relevant vehicle or other vehicles may be damaged. In addition, it adversely affects the driving stability of the vehicle and may cause an accident while driving.
- Fix the luggage to the roof rack safely, and in case of driving for a long period of time, check the fixing status of the luggage frequently. If the luggage loaded onto the roof rack falls off from the vehicle, other vehicles may be damaged or a pedestrian may get injured. Also, it may cause a bigger accident.
- When luggage is loaded onto the roof rack, the center of gravity of the vehicle becomes higher. If you control the steering wheel suddenly while applying sudden braking, making sharp turn or driving at a high speed, the vehicle may become unstable, causing an accident or overturning of the vehicle.
- If the luggage is loaded onto the roof rack, check the tightening status of roof rack fixing bolts and nuts frequently.
- Drive the vehicle at a low speed if possible when luggage is loaded onto the roof rack.

Caution

- Caution should be taken that if you load luggage onto the roof rack of a vehicle where a sunroof is installed, the luggage should not interrupt the operation of the sunroof.

Notice

- A protective gear such as a cushion or a cloth can be inserted between the luggage and the roof rack in order to prevent the vehicle from being damaged by contact between the luggage loaded onto the roof rack and the vehicle roof.

4. Starting and driving

You can check information regarding the basic equipment for safe driving, auxiliary equipment that helps you to drive comfortably, and how to use such equipment.

An explanation is provided for the START/STOP switch and smart key as well as the driving system including the instrument cluster, SBW (shift by wire), cruise control, auxiliary driving systems such as the brake and autonomous emergency braking system, rear and side warning, lane departure warning system, and parking assist system.

START/STOP switch (Smart key)*

OFF status

The power is turned off.



The indicator is turned off.

- The power is not supplied to the electric accessories of the vehicle.

! Caution

- If the SBW (shift by wire) is not placed in the P (parking) position, the START/STOP switch cannot be in the OFF status (vehicle power OFF). Also, the vehicle doors cannot be locked and it is impossible to enter the theft monitoring mode.

Notice

- When the vehicle is turned on, make sure to place the SBW (shift by wire) in the P (parking) position and turn off the vehicle by pressing the START/STOP switch.

ACC status

Some electric accessories can be used.



Orange ACC indicator turns on.

- With the START/STOP switch in the OFF status, press the START/STOP switch once without depressing the brake pedal.
- The power is supplied to the vehicle and some electric accessories can be used.

! Caution

- The START/STOP switch in the ACC status is not the status that the vehicle is turned on. Using an electric accessory in the vehicle for a long period of time in this status may deplete the battery.

ON status

Most electric accessories can be used.



Red ON indicator turns on.

- With the START/STOP switch in the OFF status, press the START/STOP switch twice without depressing the brake pedal.
- The power is supplied to the vehicle and most electric accessories can be used.

! Caution

- The START/STOP switch in the ON status is not the status that the vehicle is turned on. Using an electric accessory in the vehicle for a long period of time in this status may deplete the battery.
- If the smart key system is abnormal, the indicator blinks 5 times with the START/STOP switch in the ON status. Have your vehicle checked and serviced at a KG Mobility Authorized Service Center immediately.

READY status

Possible to start the vehicle



Green READY indicator turns on.

- This is the status that the gear shift lever is placed in the P (parking) position and the brake pedal is depressed for starting the vehicle.

! Warning

- Start the vehicle after placing it in the P (parking) position for safety.

Notice

- After you start the vehicle, the READY indicator turns off.



Warning

- Do not press the START switch while driving. If the ignition is turned off, brake performance may be reduced and the electric power steering (EPS) system may not operate, resulting in heavy steering wheel operation.



Caution

- Pressing the START switch without depressing the brake pedal only causes the start switch to switch repeatedly between “OFF > ACC > ON > OFF” and the vehicle does not start.

Notice

- Once vehicle started, the following indicators and warning lamps will illuminate depending on the driving readiness:



- Green indicator illuminated: normal driving possible
- White indicator illuminated: normal driving impossible
- Red warning lamp flashing: Not drivable due to system failure

To start vehicle

With the electronic shift lever in the P (park) or N (neutral) position and the brake pedal depressed, pressing the START switch will start the vehicle.

To start vehicle

- 1 Get in the vehicle while carrying the smart key.
- 2 Be sure that all occupants fasten their seat belt.
- 3 Check for safety that the parking brake is applied.
- 4 Turn off all electric accessories.
- 5 Place the electronic shift lever in the P (park) position.
- 6 Depress brake pedal.
- 7 Check if the READY status indicator on START/STOP switch is turned on.
- 8 If the READY status indicator is turned on, start the vehicle by pressing the START/STOP switch.
- 9 Depress the brake pedal until the vehicle starts.



Warning

- Start the vehicle with the electronic shift lever in the P (park) position.
- Repeated depression of the brake pedal without the  Ready lamp illuminated may result in a 12 V auxiliary battery discharge.
- When the smart key is inside the vehicle, pressing the START button starts the vehicle. Always be careful, especially if you have a smart key in your vehicle with someone who doesn't know these features (including adults and children), as they may cause unexpected situations.

Getting your vehicle started

- 1 When starting off the vehicle with the ignition turned on, keep the brake pedal depressed and check the  Ready lamp before operating the electronic shift lever to shift.
- 2 After releasing the parking brake, slowly release the foot from the brake pedal to ensure that the vehicle is moving slowly.
- 3 Depress the accelerator pedal slowly to start off the vehicle.

When vehicle does not start

Starting the vehicle with the dead smart key or interference, etc. (in the event of emergency)

You may not be able to start the vehicle with the START/STOP switch due to the depletion of the battery in the smart key or interference even if you are carrying the smart key in the vehicle.

In such case, take a measure as follows, replace the smart key battery or check the smart key.

Place the SBW (shift by wire) in the P (parking) position and start the vehicle by pressing the START/STOP switch directly with the smart key with the brake pedal depressed.



Notice

- If the warning buzzer is sounding, it stops.
- If you open the door while the vehicle is running when the smart key battery is depleted, a warning message saying “The smart key is not in the vehicle” appears. In such case, when you turn off and start the vehicle again, the warning message disappears.

To start vehicle when stop lamp fuse fails (emergency)

If the stop lamp fuse fails, the vehicle may not start.

In this case, pressing the START switch while ignition in ACC position for 10 seconds will start the vehicle.



Caution

- Do not start the vehicle by pressing and holding the START switch for more than 10 seconds except in an emergency. This can cause an unexpected and extremely dangerous situation because the vehicle will start without depressing the brake pedal.
- Always depress the brake pedal even though you start the vehicle in an emergency.

Stopping the vehicle

The vehicle can be turned off only when the SBW (shift by wire) is placed in the P (parking) position and the brake pedal is depressed.

- 1 After stopping the vehicle completely, keep the brake pedal depressed.
- 2 Shift the SBW (shift by wire) to the P.
- 3 Apply the parking brake.
- 4 Turn off the vehicle by pressing the START/STOP switch, and then take your foot off the brake pedal.

Be sure to check that the vehicle is turned off and if there are any other abnormalities, and get out of the vehicle with the smart key.

Stopping the vehicle while driving (in the event of emergency)

If you need to turn off the vehicle in an emergency situation such as an accident or vehicle damage while driving, press and hold down the START/STOP switch for 3 seconds or more, or press it three times within 1.5 seconds.

The vehicle is turned off and the START/STOP switch is set to the ACC status.



Warning

- **Never turn off the vehicle while driving unless there is an emergency situation such as an accident or vehicle damage. Doing so may make the steering wheel heavier and lower the brake performance, becoming very dangerous.**

Cautions for using the START/STOP switch



Warning

- The smart key system allows you to start the vehicle by pressing the START/STOP switch with the brake pedal depressed within its operation range. Caution should be taken that a person who is unfamiliar with the system such as in any other situations, especially a child, may start the vehicle.
- Never press the START/STOP switch while driving. Doing so may result in a dangerous situation due to the suspension of power supply.



Caution

- Be sure to start the vehicle with the brake pedal depressed.
- Do not depress the accelerator pedal when starting the vehicle.
- Pay particular attention not to start the vehicle when checking the vehicle from the outside, especially the motor room.
- Do not use a non genuine smart key or a replicated key.
- The communication with the smart key system is not smooth on top of the seat where the heater function is activated or the floor of the vehicle and the area near the pedal, so the smart key recognition performance may be lowered.
- The vehicle is controlled by various electronic control units. If you attach and use a device that creates radio waves or electromagnetic waves near the smart key or the vehicle, various vehicle control systems may malfunction.
- When you operate the START/STOP switch while a smartphone is placed near the smart key or charging the smartphone battery through the power socket in the vehicle, the vehicle may not start occasionally.

Smart key* & REKES key

Function of each button



Button	Press briefly	Press and hold down
1 Door lock	Lock the door	
2 Door unlock	Unlock the door (When the safety unlock is set, only the driver seat door is unlocked)	←
		Stop charging (when charging)
3 Tailgate (A type)	Stop the operation	Open/close the power tailgate
4 Panic (B type)	-	Activate/deactivate the panic mode

Notice
<ul style="list-style-type: none"> If the vehicle is charging, you can stop charging after unlocking the vehicle door by pressing and holding the door unlock button.

Locking the door

Pressing the Door lock button **(1)** briefly locks all doors and the tailgate.

- When switched to the theft deterrent mode, the hazard warning lamp blinks and a buzzer sounds.

	Hazard warning lamp	Buzzer
Smart key (type A/B)	Blinks twice	Sounds once

- If the outside Rearview mirror folding/unfolding button is in the neutral position, the outside rearview mirror is folded.
 - Refer to "Folding/unfolding the outside rearview mirror" (p.3-75)

Notice
<ul style="list-style-type: none"> If the START/STOP switch is in the ACC or the ON status or the vehicle is running, the door cannot be locked using the Door lock button.

Caution
<ul style="list-style-type: none"> The mode can be switched to the theft monitoring mode only when all doors, tailgate and hood are closed. When you press the Door lock button with the tailgate or the hood open, only the door is locked and the mode is not switched to the theft monitoring mode. After locking the door using the smart key, check that the door and the tailgate are locked completely. If the door is not locked completely, the vehicle or an article inside the vehicle may be stolen.

4

Unlocking the door (when the safety unlock is enabled)

- When the safety unlock is enabled, pressing the Door unlock button (2) only unlocks the driver seat door and cancels the theft monitoring mode.



- Pressing the Door unlock button (2) again with the driver seat door unlocked unlocks all doors and the tailgate.



- Pressing the Door unlock button (2) twice in a row unlocks the driver seat door first, then unlocks all doors and cancels the theft monitoring mode.
- When the theft deterrent mode is deactivated, the hazard warning lamp blinks and a buzzer sounds.

	Hazard warning lamp	Buzzer
Smart key (type A/B)	Blinks once	Sounds twice

- When the rear view mirror folding / unfolding button is in the neutral position, the rear view mirrors unfold.

Refer to "Folding/unfolding the outside rearview mirror" (p.3-75)

What is safety unlock?

The safety unlock function unlocks only the driver seat door when the Door unlock button is pressed once to prevent entering through a door other than the driver seat door. Pressing the Door unlock button again unlocks all doors and the tailgate.

To set safety unlock

- Tick the box at **Vehicle setting** → **Door / Tailgate** → **Press key twice to unlock** under  (user settings) in the instrument cluster.

- In theft deterrent mode, if a door, tailgate or hood is not opened within 30 seconds after the door is unlocked, all the doors are locked automatically.
- In this case, the system is switched to the theft deterrent mode, the hazard warning lamp blinks and a buzzer sounds.

	Hazard warning lamp	Buzzer
Smart key (type A/B)	Blinks twice	Sounds once

Notice
<ul style="list-style-type: none"> • In the event of auto lock after 30 seconds, the rear view mirror will not fold even if the rear view mirror folding / unfolding button is in the neutral position.

Unlocking the door (when the safety unlock is disabled)

Pressing the Door unlock button (2) briefly unlocks all doors and the tailgate.



- When the theft deterrent mode is deactivated, the hazard warning lamp blinks and a buzzer sounds.

	Hazard warning lamp	Buzzer
Smart key (type A/B)	Blinks once	Sounds twice

- If the outside Rearview mirror folding/unfolding button is in the neutral position, the outside rearview mirror is folded.

☞ Refer to "Folding/unfolding the outside rearview mirror" (p.3-75)

Opening/closing the tailgate (A type)

- You can open or close the tailgate by pressing and holding down the Tailgate button (3).
- Pressing the Tailgate button (3) briefly stops the operation of the power tailgate.
- When you approach within approximately 1 m from the center of the tailgate with the smart key, the smart tailgate operates.

☞ Refer to "Tailgate" (p.3-24)

Activating/deactivating the panic mode (B type)

When you press the Panic button in the event of emergency, the hazard warning lamp turns on and the warning buzzer sounds for a certain period of time.

- When you press and hold down the Panic button (4), the hazard warning lamp blinks and the warning buzzer sounds for approximately 30 seconds.
- Pressing and holding down the Panic button (4) again stops the panic mode.

Additional functions

Smart door auto lock (auto close)

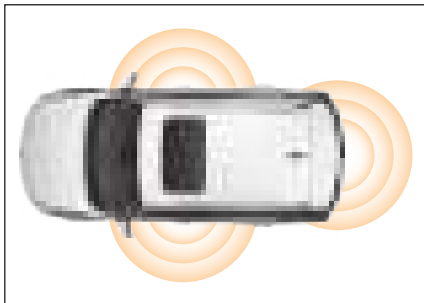

When you move a certain distance away from the vehicle while carrying the smart key, all doors and the tailgate are locked automatically.

If you stay in the smart key detection area of the vehicle for 10 minute or more under the above condition, all doors and the tailgate are also locked automatically for theft prevention.

- When the theft monitoring mode is activated, the hazard warning lamp blinks twice and the warning buzzer sounds once.
- If the Outside rearview mirror folding/unfolding button is in the neutral position, the outside rearview mirror is folded.

☞ Refer to "Folding/unfolding the outside rearview mirror" (p.3-75)

Activating the smart door auto lock function (Activating from the instrument cluster)

- Tick the box at **Vehicle setting** → **Door / Tailgate** → **Smart door auto lock** under  (user settings) in the instrument cluster.

Activating the smart door auto lock function (Activating with the smart key)

- 1 With the START/STOP switch in the ON status, press the hazard warning lamp switch.
The hazard warning lamp turns on.
- 2 Press the Door lock button on the smart key three times consecutively within 2 seconds.

Notice

- The smart door auto lock is carried out only if the smart key is detected near the vehicle (in the outside antenna area) when you close the door.
- The detection of the smart key varies depending on the walking speed and surrounding environment.
- If the smart key is present inside the vehicle, the smart door auto lock function is not activated.
- If the smart key battery is depleted, the smart door auto lock function is canceled automatically. Replace the smart key battery and activate it again from  (User Settings) on the instrument cluster.



Caution

- When you lock the door using the smart door auto lock function, check that the hazard warning lamp blinks twice and the warning buzzer sounds once. If the door is not locked completely, the vehicle or an article inside the vehicle may be stolen.

Locking/unlocking the door with the door handle switch

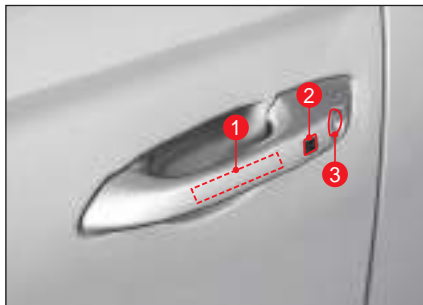
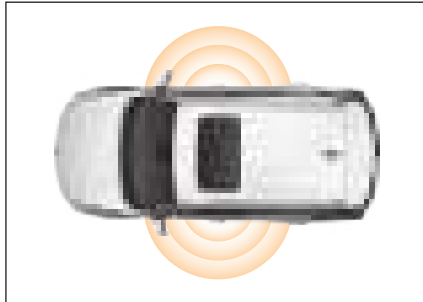

- 1 Outside antenna
- 2 Door lock/unlock button
- 3 Mechanical key hole

To lock with door handle switch

- 1 Stay in the outside antenna area of the vehicle (approximately 1 m) while carrying the smart key.
 - 2 Press the door lock / unlock button (2) with all the doors and tailgate closed.
 - 3 All the doors and tailgate are closed.
 - When the theft monitoring mode is activated, the hazard warning lamp blinks twice and the warning buzzer sounds once.
 - If the Outside rearview mirror folding/unfolding button is in the neutral position, the outside rearview mirror is folded.
- ☞ Refer to "Folding/unfolding the outside rearview mirror" (p.3-75)

Notice

- It is not possible to lock the door with the door lock / unlock button when the ignition switch is in ACC or ON position or the vehicle is started.

To unlock with door handle switch (when the safety unlock is disabled)

- 1 Stay in the outside antenna area of the vehicle (approximately 1 m) while carrying the smart key.
 - 2 Press the door lock / unlock button (2).
 - Once the smart key authentication is completed, all the doors and tailgate are unlocked.
 - When the theft monitoring mode is activated, the hazard warning lamp blinks twice and the warning buzzer sounds once.
 - If the Outside rearview mirror folding/unfolding button is in the neutral position, the outside rearview mirror is folded.
- ☞ Refer to "Folding/unfolding the outside rearview mirror" (p.3-75)



- 3 Open the driver seat door by pulling the door handle slowly.

To unlock with door handle switch (when the safety unlock is enabled)

- 1 Stay around the driver's door outside antenna area (within approx. 1m) with a smart key.
- 2 Press the door lock / unlock button (2).
 - Once the smart key authentication is completed, only the driver's door is unlocked.
 - The hazard warning lamp flashes once and buzzer sounds twice indicating that the theft deterrent mode is deactivated.
- 3 Open the door by pulling the door handle slowly.
 - Press the door lock / unlock button (2) one more time within 4 seconds with the driver's door unlocked if you want to unlock all the doors and tailgate.
 - All the doors and tailgate are unlocked.
 - The hazard warning lamp flashes once and buzzer sounds twice when all the doors are unlocked.

Notice
<ul style="list-style-type: none">• When you press the passenger's door handle lock / unlock button with the safety unlock set, all the doors are unlocked.• When you press the driver door lock / unlock button 4 seconds after the driver door is unlocked, all doors will be locked and the system enters the theft deterrent mode.

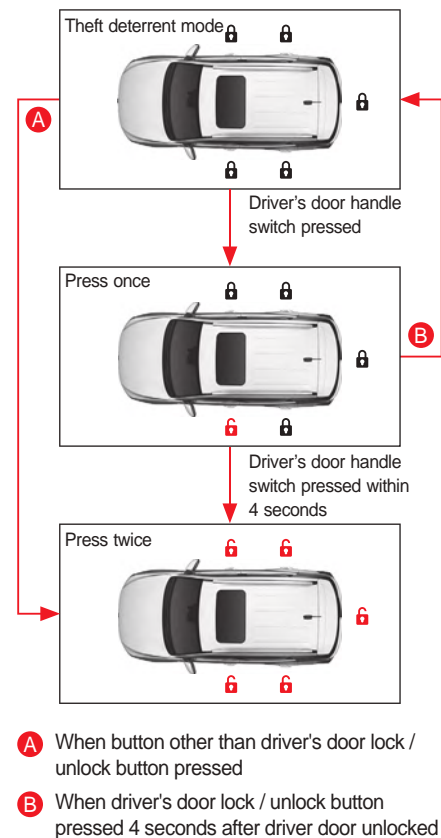

Cautions for using smart key



Warning

- Do not leave the vehicle with the smart key in the vehicle when a person (especially a child) who does not know the vehicle system is present in the vehicle. Pressing the START/STOP switch with the brake pedal depressed while the smart key is in the vehicle starts the vehicle. Other incorrect vehicle controls may occur. In such case, a serious accident may occur. Therefore, always pay attention.



Caution

If the smart key does not operate or is not recognized

- When you lock the door with the door handle lock / unlock button or another smart key outside the vehicle with the smart key inside the vehicle, the smart key in the vehicle will be disabled temporarily (buzzer sounds).

To restore to the original function, deactivate the theft deterrent mode by using the smart key outside the vehicle or door handle lock / unlock button.

- If the vehicle is in a place where strong radio waves are transmitted or received, if the vehicle is equipped with a two-way radio or other transmission and reception systems or if a smart key is used in another nearby vehicle, the smart key system may not function normally.
- The smart key recognition performance may be lowered on a blind spot above the seats where the heater function is activated or the floor of the vehicle and the area near the pedal, so the smart key system may not function. In such case, carry the smart key or place the smart key in a different location.
- If the vehicle cannot be started while the smart key is placed inside the vehicle or you are carrying it, start the vehicle by pressing the START/STOP switch with the smart key directly.
- If the smart key is near the outside windshield or the door glass, the smart key may be recognized as being present inside the vehicle. In this case, the smart key system may not operate normally.

Using the smart key

- Carry only one smart key.
- Store each smart key separately. When you lock the door using the LOCK touch sensor on the door handle instead of the Door lock/unlock button on the smart key, be careful not to leave the smart key inside the vehicle.
- If you leave the vehicle even for a moment, turn off the vehicle and carry the smart key with you and do not store a spare smart key inside the vehicle. Failure to do so may cause vehicle theft or malfunction.
- Using 2 smart keys provided by KG Mobility Corporation on one key chain at the same time may cause the smart key system to malfunction or vehicle starting failure.

Managing the smart key

- When you lock the door with another smart key with the previously used smart key in the vehicle, the door can be locked normally but you cannot start the vehicle with the key left in the vehicle until it is used normally next time. This is a safety system for preventing theft.

- Do not allow water or liquid to flow into the smart key. Caution should be taken as the smart key is not fully waterproof, so if moisture or water gets in, it may cause a malfunction that is not covered by the warranty.
- The electronic systems in the smart key are vulnerable to moisture or heat, so placing the smart key in a place with high humidity or high temperature may cause a failure.
- If the smart key is lost, you cannot open the door or start the vehicle. If you don't have a spare smart key in storage, you need to have your vehicle towed and serviced at a KG Mobility Authorized Service Center. Also, the vehicle or an article in the vehicle may be lost due to the lost smart key, so take measures immediately.

Cautions for using door handle lock / unlock button

- Anyone within the operating range of the smart key can unlock the door with the door handle lock / unlock button. Be careful of theft.
- Do not operate locking or unlocking as soon as you lock / unlock the door.

Using the emergency key

Unfolding/folding the emergency key

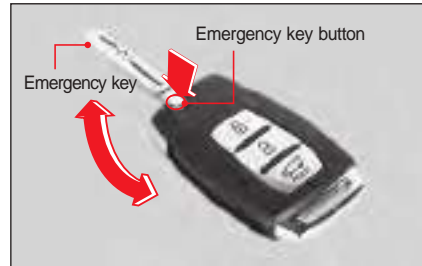

- Pull out the emergency key from the key body by pressing the Emergency key button on the smart key.
- To fold the emergency key, fold the emergency key with the Emergency key button pressed.

⚠ Caution

- Folding the emergency key forcibly without pressing the Emergency key button may damage the smart key.

Locking/unlocking the door using the emergency key

If you cannot lock/unlock the doors using a smart key because of dead battery or wave interference, use the mechanical key (secondary key) to lock/unlock the doors.

- 1 After plugging the mechanical key into the mechanical key hole of the driver's door, proceed as follows:
 - To lock the door, turn it in the lock direction (1).
 - To unlock the door, turn it in the unlock direction (2).



Notice

- When unlocking in the theft monitoring mode, the warning buzzer sounds.

Replacing the smart key battery

If the operation range of the smart key has decreased significantly or the smart key malfunctions occasionally, replace the smart key battery.

Battery standard

One CR2032 battery

- 1 Remove the cover at the back of the smart key carefully using a flat-bladed screwdriver for watches (smallest one) not to create a scratch.



- 2 Insert the battery with the positive (+) terminal facing up and the negative (-) terminal facing down.



- 3 Return the cover from the back of the smart key back to its original position.

After replacing the battery, be sure to check if the remote control key operates normally.

Caution

- The circuit inside the smart key is vulnerable to static electricity, so if you are not skilled in replacing the battery, have the smart key checked and the battery replaced at a KG Mobility Authorized Service Center.
- Be sure to replace the battery with one that meets the standard. Using a battery that does not meet the standard may cause the smart key to be inoperable due to contact failure.
- Be careful not to switch the direction of the positive (+) terminal and negative (-) terminal when inserting the battery.
- Since the battery may contaminate environments, discard it in a proper way.

Instrument cluster

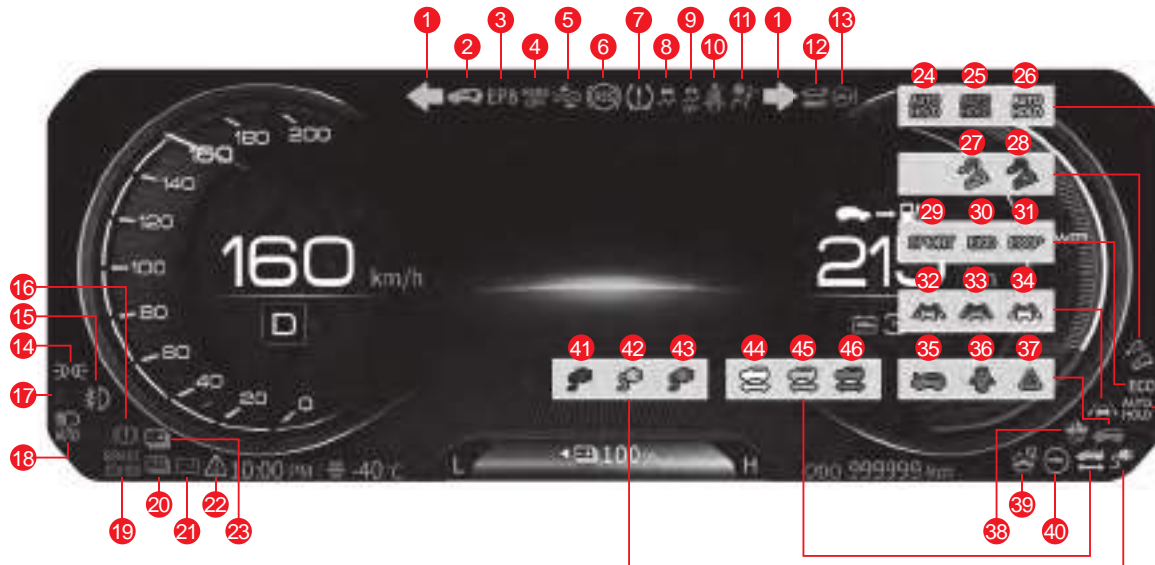

- 1 Turn signal/Hazard warning lamp
- 2 Immobilizer/Smart key warning light
- 3 EPB warning light
- 4 AEBS OFF indicator
- 5 AEBS warning light
- 6 ABS warning light
- 7 Global warning light
- 8 ESC ON indicator/warning light
- 9 ESC OFF indicator
- 10 Seat belt warning lamp
- 11 Air bag warning light
- 12 Smart tailgate indicator
- 13 EPS warning light
- 14 Illumination ON indicator
- 15 Front fog lamp ON indicator
- 16 Regenerative braking warning light
- 17 High beam indicator
- 18 SHB indicator
- 19 Brake warning light
- 20 HV battery fault warning light
- 21 LV battery warning light
- 22 Service required warning light
- 23 HV battery level warning light
- 24 AUTO HOLD indicator (green)
- 25 AUTO HOLD warning light (yellow)
- 26 AUTO HOLD READY indicator (white)
- 27 HDC ON indicator (green)
- 28 HDC warning light (red)
- 29 SPORT indicator
- 30 ECO indicator
- 31 ECO+ indicator
- 32 LKA indicator (green)
- 33 LKA warning lamp (yellow)
- 34 LKA READY indicator (white)
- 35 Hood open warning light
- 36 Door ajar warning light
- 37 Master symbol
- 38 VESS warning light
- 39 Steering wheel heater ON indicator
- 40 Power down warning light
- 41 Charging indicator (blue)
- 42 Charging indicator (green)
- 43 Charging indicator (red)
- 44 Vehicle READY indicator (white)
- 45 Vehicle READY indicator (green)
- 46 Vehicle READY indicator (red)
- 6 + 19 EBD warning light
- 16 + 19 BBS warning light

Trip info display

Speedometer



This is a gauge that measures and indicates the instantaneous vehicle speed.

Caution

- The RED marking on the speedometer (30km/h) indicates the speed limit in school zones.
- Reduce your speed to react to the unexpected and avoid a dangerous incident when driving in school zones.

POWER/CHARGE gauge



This gauge indicates the power consumption of the motor and charge/discharge status of the electrical energy recovered by regenerative braking.

- POWER
This part of the gauge indicates the power consumption of the motor when accelerating or driving uphill. The higher electrical energy consumption will push this gauge farther up the scale.
- CHARGE
This part of the gauge indicates the status of the battery charged by regenerative braking. The higher amount of electrical energy will push this gauge farther down the scale.

High Voltage (HV) battery indicator

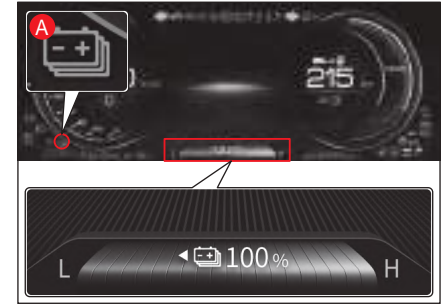

This gauge consists of 20 short bars and indicates the state of charge (SoC) of the HV battery (drive battery).

- L (Low): indicates that the HV battery level is low. When the indicator drops down to 3 bars the gauge will turn red and HV battery level warning light (A) will be illuminated.
- H (High): indicates that the HV battery is fully charged.

The left arrow next to the battery icon (◀ ) shows the charge port door is on the left-hand side of the vehicle.



Caution

- Be sure to check the HV battery level before driving off.
- Low value of charging power can be displayed on the battery indicator based on the SoC of the HV battery.
- When the SoC of the HV battery reaches a certain level, the battery can be charged with low charging power for the reasons of saving battery life or safety.
- Continuous operation with 3 or less bars of the gauge for a specified period of time will cause the vehicle speed to be limited and eventually the motor to be shut off. Immediately charge the battery at a closest charging station.

Distance To Empty (DTE)



DTE shows the approximate distance your vehicle can travel before running out of power. The DTE value is calculated based on the current SoC of the HV battery, the driving mode (SPORT, ECO, ECO+), and the accumulated data on the driver's driving pattern.

The display value ranges from 0 to 2000 km, and "---" symbol comes on if DTE value is 0 km.



Caution

- The DTE value may vary depending on the vehicle system load, the driver's driving pattern, and the road conditions, including uphill and downhill, etc.
- The display value can be changed because it is calculated based on the various conditions.
- Use the DTE value for reference only. Always check the SoC of the drive battery before driving off and charge the battery, if necessary.

Regenerative braking level indicator

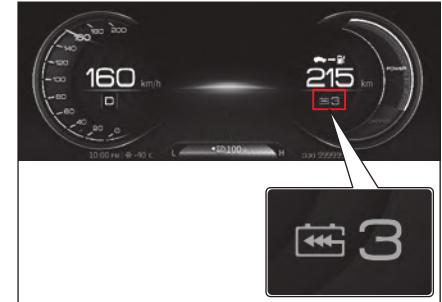

The number shown below the DTE during regenerative braking indicates the regenerative braking level currently engaged.

Three levels of regenerative braking are available (Level 1 to Level 3) through the paddle shifter.

Odometer



The total mileage of the vehicle is displayed in kilometers. The maximum mileage to be displayed is 999999 km.

Notice

- It is normal if the total mileage at the time of shipping is less than 50 km.

Electronic shift lever indicator

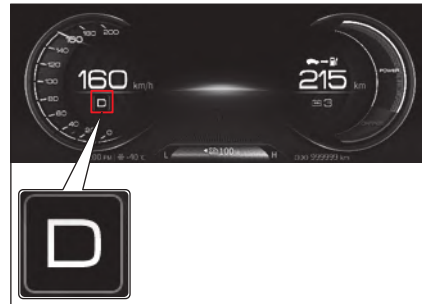

This indicator shows the current position of the electronic shift lever (P, R, N, D).

Digital clock

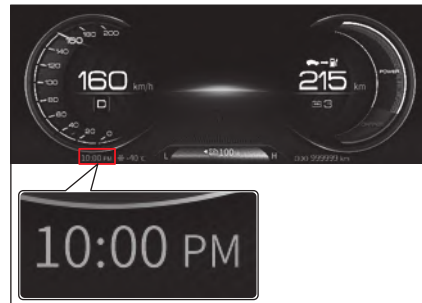

This clock displays the current time as set in the audio system in digital format.

Ambient temperature Indicator



This Indicator displays the current ambient temperature.

When the ambient temperature drops below 3°C, the ICE warning symbol (A) will come on.

Warning lights and indicators

Seat belt warning lamp



If the driver seat and front passenger seat occupants do not fasten the seat belt, the seat belt warning light blinks along with a warning buzzer.

If you fasten the seat belt at this time, the warning buzzer stops and the seat belt warning light stays on for the remaining time.

☞ Refer to “Seat belt warning” (p.2-2)

LV battery warning light



This warning light comes on when the LV battery is depleted or a fault has developed in the charging system such as Low DC-DC Converter (LDC).

Warning

- If the LV battery warning light is turned on, have the vehicle checked and serviced immediately at a KG Mobility Dealer or KG Mobility Authorized Service Center.
- If this light turns on, it may indicate that the LV battery is completely drained or the vehicle speed and/or some functions are limited.
- Continuous driving with this light ON can result in your vehicle not starting.

Air bag warning lamp



The air bag warning lamp turns on when the START/STOP switch is in the ON status, and it turns off when there is no abnormality in the air bag system.

If the warning light stays on after starting the vehicle, the air bag system is abnormal. Have your vehicle checked and serviced at a KG Mobility Authorized Service Center immediately.

☞ Refer to “Air bag” (p.2-20)

Brake warning light

BRAKE

(!) (P)

The brake warning light turns on when the START/STOP switch is in the ON status and turns off approximately 4 seconds later.

This warning light turns on when the parking brake is applied or the brake fluid is insufficient.



Warning

- If the brake warning light stays on if the parking brake is released, it indicates that the brake fluid is insufficient. Have your vehicle checked and serviced at a KG Mobility Authorized Service Center immediately.
- Driving the vehicle continuously with insufficient brake fluid lowers the brake performance since the pressure of brake fluid cannot be transferred normally.

Notice

Driving the vehicle with insufficient brake fluid causes the brake warning light to operate as follows.

- Turn on: When driving the vehicle at a speed of approximately 10 km/h or less
- Blink: When driving the vehicle at a speed of approximately 10km/h or higher for 2 seconds or more

Hill Descent Control (HDC) ON indicator/warning light



When you press the HDC switch, the system is switched to the HDC operation ready status and the green HDC indicator turns on.

When you press the HDC switch again, the indicator turns off and the HDC function is deactivated.

The HDC ON indicator operates as follows according to the status.

- Green indicator turns on: The HDC is in ready status.
- Green indicator blinks: The HDC is operating.
- Red warning light turns on: The HDC system is overheated and abnormal.

☞ Refer to "Hill Descent Control (HDC)" (p.4-134)



Caution

- When the red warning light turns on, have your vehicle checked and serviced at a KG Mobility Authorized Service Center.

Electric power steering warning light



The electric power steering warning light turns on when the ignition switch is turned on and turns off when the ignition is turned on.

This warning lamp lights on in the event of faulty electric power steering (EPS) system.



Caution

- If the electric power steering warning light comes on or the steering wheel feels heavy, please have it checked and serviced at a KG Mobility Dealer or KG Mobility Authorized Service Center.

Notice

- If you keep the steering wheel turned to the left or right all the way while the vehicle is stationary, the warning light will blink as the steering wheel becomes heavy. This is a safety feature to protect the system and will return to normal after some time.
- The EPS (Electronic Power Steering) system is mounted in the steering handle. This system includes functions to compensate the steering power, interlocking with ESC, the supplementary driving safety system, when cornering or braking on the road with different friction. You may feel some difference in steering when these functions are in operation.

Electronic stability control system (ESC) ON indicator/warning light



The ESC ON indicator turns on when the START/STOP switch is in the ON status and turns off approximately 4 seconds later.

- Indicator blinks: When the ESC function is activated
- Warning light turns on: When the ESC system is abnormal



Caution

- If the ESC ON warning lamp turns on, have your vehicle checked and serviced at a KG Mobility Authorized Service Center.

Electronic stability control system (ESC) OFF indicator



The ESC OFF indicator turns on when the START/STOP switch is in the ON status and turns off approximately 4 seconds later.

Pressing and holding down the ESC OFF switch (approximately 3 seconds or more) deactivates the ESC function and the ESC OFF indicator turns on.

☞ Refer to "When it is necessary to deactivate the ESC function" (p.4-133)

ABS (Anti-Lock Brake System) warning light



The ABS warning light turns on when the START/STOP switch is in the ON status and turns off approximately 4 seconds later.

This warning light turns on when the ABS system is abnormal.



Warning

- If the ABS warning light turns on, the ABS function does not operate and only normal brake function operates. In such case, have your vehicle checked and serviced at a KG Mobility Authorized Service Center immediately.

Notice

- A vehicle equipped with the ABS system has the self-diagnosis function to check the internal hydraulic system to see if there is an abnormality by transferring the hydraulic pressure to the internal hydraulic system after the vehicle is started. At this time, a vibration and a noise may occur at the brake pedal. This indicates that the ABS is functioning normally.

Electronic Brake-Force Distribution (EBD) warning light



If the EBD system is abnormal, the ABS warning light and the brake warning light turn on at the same time.

In such case, drive the vehicle carefully since the vehicle may become unstable if you apply sudden braking.



Warning

- If the EBD warning light turns on, have your vehicle checked and serviced at a KG Mobility Authorized Service Center immediately.
- If the EBD warning light turns on, the EBD function as well as the ABS function do not operate.

Regenerative braking warning light



This warning light comes on for about 4 seconds and then goes off when the START/STOP switch is turned ON.

This warning light is illuminated when the regenerative braking system is malfunctioning.



Warning

- If the regenerative braking warning light is illuminated, additional time or brake pedal travel may be required to stop the vehicle. If this occurs, carefully drive the vehicle to a KG Mobility Dealer or KG Mobility Authorized Service Center and have the vehicle checked and serviced.

Base Brake System (BBS) warning light



This warning light comes on for about 4 seconds and then goes off when the START/STOP switch is turned ON.

This warning light is illuminated when the brake system is malfunctioning.

Warning

- If the BBS warning light is illuminated, additional time or brake pedal travel may be required to stop the vehicle. If this occurs, carefully drive the vehicle to a KG Mobility Dealer or KG Mobility Authorized Service Center and have the vehicle checked and serviced.

Global warning light



The global warning light turns on when the START/STOP switch is in the ON status and turns off approximately 4 seconds later.

If the tire pressure monitoring system (TPMS) is abnormal, the global warning light blinks (for approximately 70 seconds) and then stays on. This warning light also turns on if the tire pressure is abnormal (underinflated/overinflated/flat).

 Refer to "Tire pressure monitoring system (TPMS)" (p.2-29)

Warning

- If the global warning light turns on, be sure to park your vehicle at a safe place and check the tire pressure. If this warning light stays on, have your vehicle checked and serviced at a KG Mobility Authorized Service Center.

Steering wheel heater indicator*



If you press the Steering wheel heater button with the START/STOP switch in the ON status or while the vehicle is running, the steering wheel heater indicator turns on or turns off.

Notice

- When the steering wheel heater indicator turns on, the heater ON/OFF status message is displayed on top of the display of the instrument cluster for approximately 5 seconds.

Immobilizer/smart key warning light



If the smart key system is abnormal or the smart key (transponder) authentication fails, the warning light blinks.

Caution

- If the warning light blinks continuously, have your vehicle checked and serviced at a KG Mobility Authorized Service Center.

Electronic Parking Brake (EPB) warning light*

EPB

The Electronic Parking Brake (EPB) warning light turns on when the START/STOP switch is in the ON status and turns off approximately 4 seconds later.

The amber warning light will come on in the event of the faulty electric parking brake (EPB) system.

Warning

- If the Electronic Parking Brake (EPB) warning light turns on, have your vehicle checked and serviced at a KG Mobility Authorized Service Center.
- If you need to park the vehicle with the parking brake not functioning due to the failure of the Electronic Parking Brake (EPB) in an emergency, stop the vehicle on safe flat ground and place the gear shift lever in the P (parking) position.

Autonomous Emergency Braking System (AEBS) warning light



The AEBS warning light turns on when the START/STOP switch is in the ON status and turns off approximately 4 seconds later.

If the collision with a front vehicle is expected with the AEBS function activated, the AEBS warning light operates as follows along with a warning buzzer.

- Blink: The AEBS is operating (It operates for 5 second when a collision warning is given.)
- Turn on: The AEBS is abnormal

 Refer to "Autonomous Emergency Braking (AEB)" (p.4-141)

Autonomous Emergency Braking System (AEBS) OFF indicator

AEBS OFF

The AEBS OFF indicator turns on when the START/STOP switch is in the ON status and it turns off approximately 4 seconds later.

When the AEBS is deactivated and the ESC function is disabled, the AEBS indicator turns on, stopping the AEBS operation.

Turn signal/hazard warning lamp



- When you push the light switch down, the left turn signal blinks.
- When you push the light switch up, the right turn signal blinks.
- When you push the hazard warning lamp switch, the left and right turn signals blink at the same time.

Illumination ON indicator



When you turn on the head light or the tail light using the light switch, the illumination ON indicator turns on.

Front fog lamp ON indicator*



When you place the light switch in  (front fog light) position with the head light or the tail light turned on, the front fog light turns on and the indicator turns on.

For a vehicle equipped with the Daytime Running Light (DRL), when you place the light switch in the  (front fog light) position with the switch in the ON status, the front fog light turns on.

Rear fog lamp ON indicator



With the headlights turned on, if you rotate the switch in  position, rear fog lights turn on and the switch returns back in front fog light position. Rear and front fog lights turn on simultaneously.

ECO indicator

ECO

This indicator is turned ON when the ECO mode (economical drive mode) is selected by pressing the drive mode button.

- Pressing the drive mode button will toggle the drive mode as follows:
COMFORT → SPORT → ECO
 - In either mode, press and hold the switch for more than 2 seconds to enter Eco+.

Notice

- **There is no indicator lamp for normal drive mode (COMFORT).**

 Refer to “Drive mode switch” (p.4-107)

ECO+ indicator

ECO+

This indicator is turned ON when the ECO+ mode (extreme power saving) is selected by pressing the drive mode button.

SPORT indicator

SPORT

This indicator is turned ON when the SPORT mode (sporty drive mode) is selected by pressing the drive mode button.

SHB indicator*



The SHB indicator turns on when the START/STOP switch is in the ON status and turns off approximately 4 seconds later.

When you push the switch in the direction of the instrument cluster with the light switch in the AUTO position, the SHB is activated and the indicator turns on.

☞ Refer to "Smart High Beam (SHB)" (p.3-60)

 Caution

In any of the following cases, the SHB may not operate normally.

- When the vehicle windshield is damaged or contaminated by dust, mist, fog, sticker, snow, etc
- When the lamp of an oncoming vehicle or a vehicle at the front is damaged
- When an oncoming vehicle or a vehicle at the front is out of your front sight
- When an oncoming vehicle and a vehicle at the front are recognized only partially in an intersection or a winding road
- When there is a light source similar to a vehicle lamp or a reflector at the front
- When an illuminator or a reflector is installed in a construction section, etc.

AUTO HOLD indicator/warning light*

AUTO HOLD

When you press the AUTO HOLD button, the AUTO HOLD system enters the ready mode and the white AUTO HOLD indicator on the instrument cluster turns on.

When you press the AUTO HOLD button again, the AUTO HOLD indicator turns off and the AUTO HOLD system is deactivated.

The color of the AUTO HOLD indicator changes as follows according to the status.

- White indicator: AUTO HOLD system in ready mode
- Green indicator: AUTO HOLD system is activated
- Yellow indicator: AUTO HOLD system is abnormal

 Warning

- If the yellow warning light turns on, have your vehicle checked and serviced at a KG Mobility Authorized Service Center.

LKA (LDW) indicator / warning lamp



Pressing the lane keeping assistance (departure) switch activates the lane keeping and lane departure alerts depending on the vehicle setting.

☞ Refer to “LDW (Lane Departure Warning)” (p.4-157)

☞ Refer to “Lane Keeping Assistance (LKA)” (p.4-163)

 Warning

- If the yellow warning light turns on or blinks, have your vehicle checked and serviced at a KG Mobility Authorized Service Center.

High beam indicator



When you push the light switch in the direction of the instrument cluster and release it, the high beam turns on and the high beam indicator turns on.

Warning

- **Driving the vehicle with the high beam turned on may block the vision of the driver in an oncoming vehicle and interfere with safe driving. Therefore, use the high beam only if the surrounding is too dark or it is difficult to predict the front situation when you drive at night.**

Vehicle READY indicator



This indicator comes on for about 4 seconds and then goes off when the START/STOP switch is turned ON.

This indicator shows the ready status of the vehicle and changes its color based on the status.

- Solid Green: You can drive the vehicle normally.
- Solid White: The vehicle cannot be driven or In the event of malfunction.
- Blinks Red: Emergency driving.

Warning

- **If the vehicle READY indicator doesn't come on solid green or blinks red, have the vehicle checked and serviced at a KG Mobility Dealer or KG Mobility Authorized Service Center.**

Service required warning light



This warning light comes on when there is a fault in the units, sensors, actuators, or climate control system related to the EV control system.

Warning

- **If the service required warning light comes on while driving or does not go off after starting, have the vehicle checked and serviced immediately at a KG Mobility Dealer or KG Mobility Authorized Service Center.**

Power down warning light



This warning light comes on for about 4 seconds and then goes off when the START/STOP switch is turned ON.

For safety reasons, this warning light comes on and the motor power is limited when:

- the SoC of the drive battery is below a specified level or there is a sudden drop of the battery voltage.
- the temperature of the drive motor or HV battery is too high or too low.
- there is a fault in the cooling system.
- there is a problem which makes it impossible to drive normally.

Warning

- Do not abruptly drive off or sharply accelerate vehicle when the power down warning light is ON.
- If the SoC of the drive battery is low, the power down warning light comes on and the motor power is limited. Charge the battery immediately when this warning light is illuminated. Otherwise, the vehicle could descend backward or driving forward will be difficult on a steep hill.

Charging indicator



This indicator comes on for about 4 seconds and then goes off when the START/STOP switch is turned ON.

The charging indicator operates as follows:

- Green indicator lit: Charging plug connected or charging completed
- Green indicator flashing: Charging in progress
- Blue indicator lit: Waiting for scheduled charging
- Red indicator flashing: Faulty charging system or charging plug not connected correctly

HV battery level warning light



This warning light comes on when the SoC of the HV battery is low.

Warning

- If the HV battery level warning light is illuminated, charge the battery immediately at a charging station.
- Charging the battery immediately is necessary, because when the HV battery level warning light is turned on, the DTE is around 20 km. Please keep in mind that the DTE value may vary depending on the driving conditions.

HV battery fault warning light



This warning light comes on when there is a fault in the units or sensors related to the HV battery control system.

Warning

- If the HV battery warning light is turned on, have the vehicle checked and serviced immediately at a KG Mobility Dealer or KG Mobility Authorized Service Center.

Virtual Engine Sound System (VESS) warning light



This warning light is turned on when the VESS is malfunctioning.

Warning

- If the VESS warning light is illuminated, have the vehicle checked and serviced at a KG Mobility Dealer or KG Mobility Authorized Service Center.

Door ajar warning light



This warning light comes on when a door or the tailgate is open or ajar.

Warning

- Make sure all doors and the tailgate are fully closed before driving off. Driving with any door and/or the tailgate ajar poses a significant risk to the safety of occupants.

Notice

- The priority of indicators is as follows:
Hood open warning light > Door ajar warning light > Master symbols

Motor room hood open warning light



This warning light comes on when the motor room hood is open or ajar.



Warning

- Check that the motor room hood is fully latched in position before driving. Driving with the motor room hood open can result in damage to your vehicle or cause a serious accident by obstructing your view.

Notice

- The priority of indicators is as follows:
Hood open warning light > Door ajar warning light > Master symbols

Smart tailgate indicator



SMART

This indicator comes on for about 4 seconds and then goes off when the START/STOP switch is turned ON.

The smart tailgate indicator can be turned on by selecting the item Smart Tailgate under User Settings menu of the instrument cluster.

- Instrument cluster setting (Indicator ON)
To use this indicator function, select the item Smart Tailgate under  (User Settings) → Vehicle Settings Door / Tailgate from the instrument cluster.

Master symbol



The master symbol is turned on when there are warning messages stored in the vehicle system. If the master symbol is illuminated, be sure to check the vehicle warning message.





Notice

- You can check the vehicle warning message(s) under User Settings menu from the instrument cluster.
- When there is no warning message this symbol is not displayed.
- The priority of indicators is as follows:
Hood open warning light > Door ajar warning light > Master symbols



Indicator panel on instrument cluster

Main menu



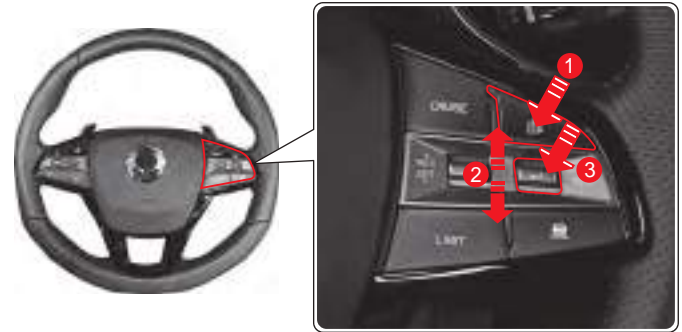



You can check the driving information of the vehicle including mileage and driving time or change the settings through the main menu from the display of the instrument cluster.

- 1 Press the  (menu) button on the right side of the steering wheel.
 - The display moves to the main menu list.
 - Go to upper menu when entering User Settings menu.
- 2 Move to the desired submenu by raising or lowering the  (moving) lever.
- 3 Press the  (select) button briefly to enter the menu, change the setting and confirm.
Pressing and holding down the  (selection) button resets the driving information of the vehicle.



Button and lever	Operation	Function
 1 Menu button	Press briefly	<ul style="list-style-type: none">• Move to the main menu• Go to upper menu when entering User Settings menu
 2 Moving lever	Raise/lower briefly	<ul style="list-style-type: none">• Move to the submenu (mode)
 3 Selection button	Press briefly	<ul style="list-style-type: none">• Enter the menu• Check/select the setting
	Press and hold down	<ul style="list-style-type: none">• Reset the driving information of the vehicle• Reset selected item

Main menu list

Main menu	Description
 Trip computer information	<ul style="list-style-type: none">• Trip A (Distance/AVG. Speed/Driving Time)• Trip B (Distance/AVG. Speed/Driving Time)• Efficiency Info. (AVG. Fuel)• Power consumption (Accumulated use rate / instant consumption)• Change information• Energy flow• Display the status of the tire pressure monitoring system (TPMS)
 Digital speedometer	<ul style="list-style-type: none">• Display the current vehicle speed in digital numbers.(four different modes)
 Driving assist Menu	<ul style="list-style-type: none">• Driver assistance system operation status display• Driver Attention Warning (DAW)
 AV screen	<ul style="list-style-type: none">• Display audio (AV)-linked screen
 TBT (Turn By Turn)	<ul style="list-style-type: none">• Display navigation-linked screen
 User settings	<ul style="list-style-type: none">• Driving Assist• Dashboard Settings• Vehicle Settings• Reset All Settings

Trip computer information

Mileage/average speed/driving time



The distance that the vehicle traveled (km), average speed (km/h) and driving time (hh:mm) are displayed.

1 Mileage (A/B)

The distance vehicle traveled after resetting Trip A/B is displayed.

The distance to be displayed ranges between 0.0 km and 9999.9 km.

When the distance exceeds 9999.9 km, it returns to 0.0 km.

2 Average speed (A/B)

The average speed calculated based on the time and distance and it is updated every 10 seconds.

3 Driving time (A/B)

The time to be displayed ranges between 0:00 and 99:59, and when the time exceeds this range, it returns to 0:00.

Resetting the mileage/average speed/driving time

Press and hold down the  (select) button in the current mode.

The average speed is reseted to “--” and the driving time is reseted to “0:00”.

Fuel economy

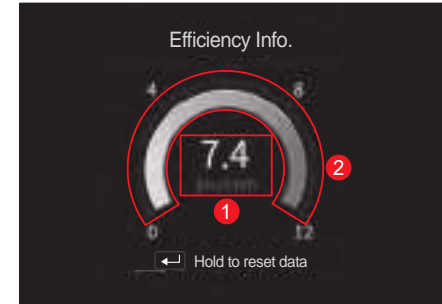

1 Average fuel economy

This value indicates the average fuel economy calculated from the total power consumption and distance traveled after resetting (--.--).

The fuel economy represents the distance traveled per 1 kWh, and it is updated every 10 seconds.

Display range

- Less than 100 km/kWh: 0 to 99.9 km/kWh
- 100 km/kWh or more: 100 to 999 km/kWh

2 Instantaneous fuel economy

The instantaneous fuel economy is calculated from the distance traveled and the amount of power consumption.

This value is displayed when the vehicle is driven at 5 km/h or more and will range from 0 to 12 km/L.

To reset the average fuel consumption

Press and hold the  (select) button in current mode.

It will be reset to "--.--" and new average value will appear after driving for some time.

Notice

- The distance and power consumption do not count up while charging the battery.
- The initial fuel economy value appears after driving more than 50 m or for more than 10 seconds.
- To change the settings for average fuel economy auto reset move to  (User Settings) of the instrument cluster and select as follows: Instrument cluster settings → Instrument cluster setup & information → Average fuel economy auto reset (OFF / Reset when charging / Reset when starting).

Power consumption

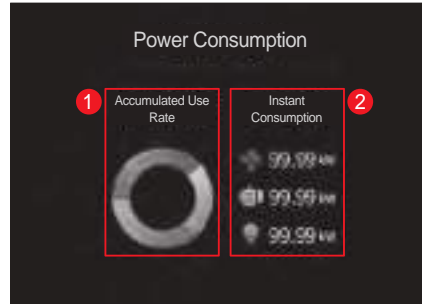

The total and instantaneous amount of power consumed by an EV (for driving, climate control, electronics) will be displayed on the screen.

The unit of the value is kW, and it is updated every second.

1 Total power consumption

The total amount of power consumed after IGN ON in percentage.

2 Instantaneous power consumption

The power consumption value will range as follows:

 For driving: -300 to 300 kW

 For climate control: 0 to 99.99 kW

 For electronics: 0 to 99.99 kW

Charge Information

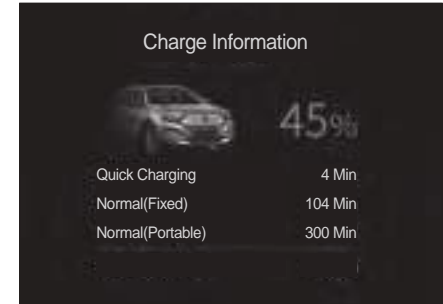

This indicates the current charging status.

- Quick charging time
- Normal (fixed) charging time
- Normal (portable) charging time
- Charge amount

Power flow

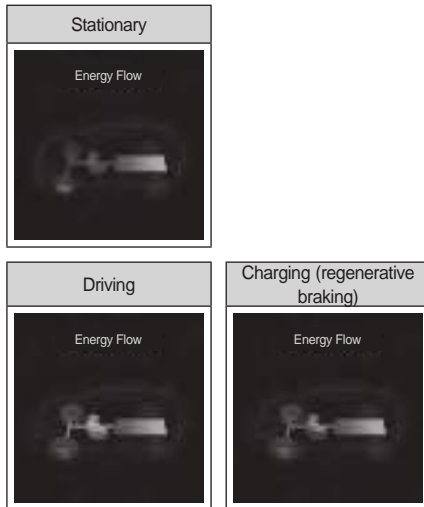

The power flow shows the charging status of the vehicle when driving and charging.

- Stationary: motor not running (no energy flow)
- Driving: motor running (energy flows from battery to wheel)
- Charging (regenerative braking): charging HV battery using regenerative braking when decelerating (energy flows from battery to wheel)

TPMS status



A message indicating the status of tire pressure is displayed.

- If the tire pressure is normal, "Tire pressure OK" is displayed.
- If the tire pressure is abnormal, the corresponding message according to the degree of abnormal tire pressure is displayed, and this message stays on or blinks depending on the tire pressure condition.

☞ Refer to "Tire pressure monitoring system (TPMS)" (p.2-29)

Notice

- **Approximately 15 seconds after entering the tire pressure mode, it will automatically switch to "Distance to empty / Average fuel economy / Instant fuel economy" mode.**

Digital speedometer

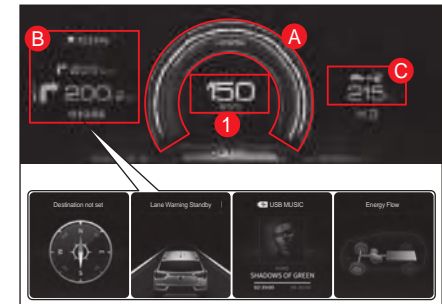

- 1 Displays instantaneous vehicle speed in digital format in the center of the instrument cluster with the following additional information.
- A POWER/CHARGE gauge in the center of the instrument cluster.
- B Four display modes on the left side of the screen, selectable with the lever. (navigation ↔ driving assistant ↔ AV media ↔ power flow)
- C The DTE and regenerative braking status are displayed on the right side of the screen.

Driving assist Menu

Driving assist



When detecting the lanes according to the vehicle condition, the detected lane is displayed in white and alarm can be issued at the detected lane. Depending on the operating system, the front vehicle is displayed.

The following are the systems that can display the front vehicle in the driving assistance menu:

- Lane departure warning (LDW)
- Lane keeping assistance (LKA)
- ELK
- LKA hands-off display
- Auto cruise
- Adaptive cruise control (ACC)
- Intelligent Adaptive cruise control (iACC)
- Speed limit alert
- Safety speed assist

Driver attention alert



The driver's "Cautious driving level" is displayed in 5 steps and the driver can determine the his/her own current cautious driving level.













The "Cautious driving level" is lowered to a poor level according to the driver's travel pattern analysis and when driving for a long period of time without rest.

AV screen



The audio (AV) screen linked with the audio (AV) system is displayed.

The image displayed on the position of main menu at the top varies as follows depending on the mode or the function that is used currently.

Image	Mode/function
	Radio mode
	i-Pod mode
	Bluetooth music playback mode
	USB mode
	USB/SD photo mode
	Bluetooth hands-free mode
	Connectivity (Apple Car Play mode)
	USB/SD video mode
	USB/SD music mode
	MY MUSIC
	Android Auto
	Voice memo

TBT (Turn By Turn)



The navigation screen information is displayed partially in linkage with the navigation system.

If the system is not interlocked with the navigation system.

User settings

※ The menu configuration may vary according to the instrument panel specifications.

Setting menu	Level 1	Level 2	Level 3	Remark
Driving Assist	Front Safety Aid	Autonomous Emergency Braking (AEB) <input checked="" type="checkbox"/>	Tick/Not tick (AEBS OFF warning lamp lights on when unticked)	
		Forward Collision Sensitivity	Slow <input type="radio"/>	
			Medium <input checked="" type="radio"/>	
			Fast <input type="radio"/>	
		Speed Limit Warning	Off <input type="radio"/>	
			On <input checked="" type="radio"/>	
		LDW & LKA Setting	Lane Departure Warning (LDW) <input type="radio"/>	
			Lane Keeping Assist (LKA) <input checked="" type="radio"/>	
			Emergency Lane Keeping (ELK) <input checked="" type="checkbox"/>	Tick/Not tick
		Adaptive Cruise Level	COMFORT <input type="radio"/>	
			NORMAL <input checked="" type="radio"/>	
			DYNAMIC <input type="radio"/>	
Intelligent Adaptive Cruise <input checked="" type="checkbox"/>		Tick/Not tick		
TSR <input checked="" type="checkbox"/>		Tick/Not tick		
TSR Warning <input type="checkbox"/>		Tick/Not tick		
Front Vehicle Start Warning <input type="checkbox"/>		Tick/Not tick		
Driver Attention Alert (DAA) <input type="checkbox"/>		Tick/Not tick		
Safety Distance Alert (SDA) <input type="checkbox"/>		Tick/Not tick		
HELP			-	

Setting menu	Level 1	Level 2	Level 3	Remark	
Driving Assist	Rear Side Safety Aid	Rear Cross Traffic Warning & Collision <input checked="" type="checkbox"/>	Tick/Not tick		
		Safety Exit Warning (SEW) <input checked="" type="checkbox"/>	Tick/Not tick		
	Parking Safety Aid	HELP			
		Front Obstacle Warning Auto-On <input checked="" type="checkbox"/>	Tick/Not tick		
Dashboard Settings	Dashboard Settings & Info	Fuel Economy Reset	Off <input type="radio"/>		
			Reset After Charging <input checked="" type="radio"/>		
			Reset After Ignition <input type="radio"/>		
		Fuel Economy Unit	km/kWh <input checked="" type="radio"/>		
			kWh/100km <input type="radio"/>		
		Temperature Unit	°C <input checked="" type="radio"/>		
			°F <input type="radio"/>		
	Tire Pressure Unit		psi <input checked="" type="radio"/>		
			kPa <input type="radio"/>		
			bar <input type="radio"/>		
			kgf/cm ² <input type="radio"/>		
	Warning Light Info		HELP		
		Checkup Alert	Activate Checkup Alert <input checked="" type="checkbox"/>	Tick/Not tick	
Tire					
Others					
	HELP				







Setting menu	Level 1	Level 2	Level 3	Remark	
Dashboard Settings	Sound	Warning Sound Type	BASIC	●	
			NATURE	○	
			CLASSIC	○	
			TRENDY	○	
			KOREAN	○	
			LUXURY	○	
		Turn Signal Sound Volume	Set level 0, 1, 2 or 3		
	Parking Assist (PA) Volume				
	Blind Spot System Sound		Blind Spot Warning (BSW) Sound	<input checked="" type="checkbox"/>	
			Rear Cross Traffic (RCTW) Sound	<input checked="" type="checkbox"/>	
			Safety Exit Warning (SEW) Sound	<input checked="" type="checkbox"/>	
	Welcome & Goodbye Sound	<input checked="" type="checkbox"/>	Tick/Not tick		
	HELP		-		
	Virtual Engine Sound System	Activate Vehicle Lock&Unlock Sound	<input checked="" type="checkbox"/>	Tick/Not tick	
		Virtual Engine Sound Type	Virtual Engine Sound 1	●	
			Virtual Engine Sound 2	○	
		HELP		-	
Display Settings	Automatic Switching	●			
	COMFORT	○			
	ECO	○			
	SPORT	○			
	HELP		-		



Setting menu	Level 1	Level 2	Level 3	Remark	
Vehicle settings	Door/Tailgate	Auto Lock	Off	<input type="radio"/>	
			Driving	<input checked="" type="radio"/>	
			Shifting to R,N,D	<input type="radio"/>	
		Auto Unlock	Off	<input type="radio"/>	
			Engine Off	<input checked="" type="radio"/>	
			Shifting to P	<input type="radio"/>	
		Auto Lock Speed Setting	10km/h	<input type="radio"/>	
			20km/h	<input type="radio"/>	
			30km/h	<input checked="" type="radio"/>	
			40km/h	<input type="radio"/>	
			50km/h	<input type="radio"/>	
		Lock/Unlock Sound	<input checked="" type="checkbox"/>	Tick/Not tick	
Press key twice to unlock	<input type="checkbox"/>	Tick/Not tick			
Smart Door Auto Lock	<input checked="" type="checkbox"/>	Tick/Not tick			
Power Tailgate	Activate	<input checked="" type="radio"/>			
	Deactivate	<input type="radio"/>			
Smart Tailgate	Activate	<input checked="" type="radio"/>			
	Deactivate	<input type="radio"/>			
HELP		-			

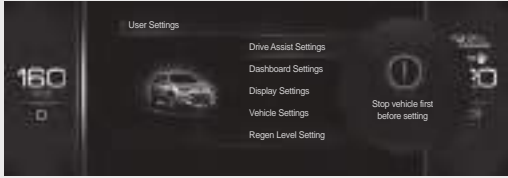

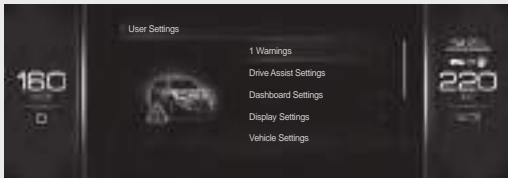
Setting menu	Level 1	Level 2	Level 3	Remark	
Vehicle settings	Light	Leaving-Home Headlamp	Deactivate <input type="radio"/>		
			10 sec. <input checked="" type="radio"/>		
		Coming-Home Headlamp	20 sec. <input type="radio"/>		
			30 sec. <input type="radio"/>		
		HELP	-		
	Convenience	Steering Wheel Alignment Alert	<input checked="" type="checkbox"/>	Tick/Not tick	
		Wiper Mode Display	<input checked="" type="checkbox"/>	Tick/Not tick	
		Light Mode Display	<input checked="" type="checkbox"/>	Tick/Not tick	
		Approach Welcome	<input type="checkbox"/>	Tick/Not tick	
		Auto Approach Welcome	<input type="checkbox"/>	Tick/Not tick	
		Long-Term Parking	<input type="checkbox"/>	Tick/Not tick	
Wireless Charging System		<input type="checkbox"/>	Tick/Not tick		
	HELP	-			

Message on the display of the instrument cluster

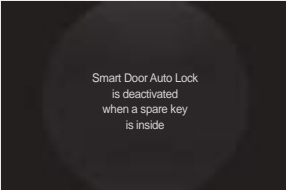
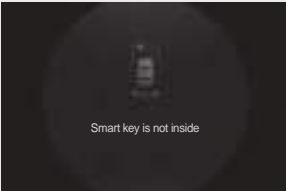



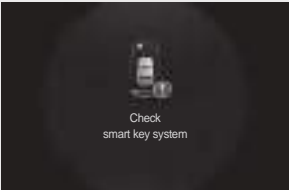



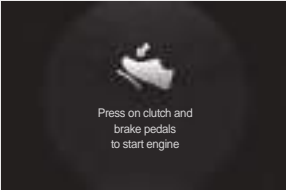
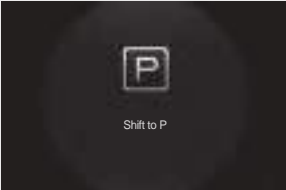
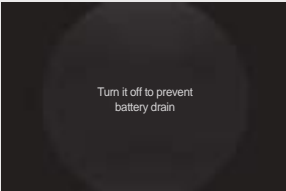















The images in the below messages are based on the standard instrument cluster for visibility and depend on the instrument panel specifications.







Item	Message	Activation conditions
Welcome message and sound		<ul style="list-style-type: none"> • If you tick the box at Sound → Welcome & Goodbye Sound display under  (User Settings) in the instrument cluster, this message is displayed for 4 seconds when the theft deterrent mode is deactivated and the driver door is open and closed. • When you change the START/STOP switch to the ON status while the message is being displayed, the message disappears but the sound is played to the end.
Instrument cluster settings		<ul style="list-style-type: none"> • If a vehicle speed is detected when you enter the User Settings menu and carry out the detailed setting, the relevant warning message is displayed for approximately 5 seconds. • However, the instrument cluster illumination, driving assist and vehicle warning menu are excluded.
ICE warning light		<ul style="list-style-type: none"> • The ICE warning pop-up (1) is displayed as a pop-up message for 5 seconds when the ambient temperature falls 5°C or below. • The ICE warning symbol (2) is displayed in the ambient temperature display at top of the instrument panel. • ICE warning symbol is turned off when the ambient temperature is 7°C or higher.
Vehicle warning log		<ul style="list-style-type: none"> • You can see the vehicle warning messages from  (User Settings) on the instrument cluster. <ul style="list-style-type: none"> – When the warning message is available at the vehicle, the custom symbol is changed to the master symbol. – When the warning message is not available, the corresponding item is not displayed.

Item	Message	Activation conditions
Smart key warning	 <p>Smart key is inside</p>	<ul style="list-style-type: none"> When you about to close the door with another authenticated smart key or door handle switch while all the doors are closed and the authenticated smart key is inside the vehicle, this message will be displayed for 5 seconds.
	 <p>Smart Door Auto Lock is deactivated when a spare key is inside</p>	<ul style="list-style-type: none"> If two or more authenticated smart keys are in the vehicle when a door is opened (excluding the hood and tailgate) after the vehicle is turned off, this message is displayed for approximately 5 seconds.
	 <p>Smart key is not inside</p>	<ul style="list-style-type: none"> If no smart key is in the vehicle with the START/STOP switch in the ON status or when the vehicle is running, this message is displayed.
	 <p>Press START with smart key</p>	<ul style="list-style-type: none"> If no authenticated smart key is detected when the START/STOP switch is pressed, this message is displayed for approximately 5 seconds.





Item	Message	Activation conditions
Smart key warning	 <p>Check smart key system</p>	<ul style="list-style-type: none"> • If the vehicle power control from the smart key module or the START/STOP switch is abnormal or an incorrect signal or no signal is received after the smart key is authenticated, this message is displayed for approximately 5 seconds. • If the message persists, visit a nearby KG Mobility Authorized Service Center.
	 <p>Replace smart key battery</p>	<ul style="list-style-type: none"> • If the battery level of the smart key is low with the auto lock function disabled, this message is displayed for approximately 5 seconds.
	<p>Smart Door Auto Lock is deactivated. Replace smart key battery, then reset</p>	<ul style="list-style-type: none"> • If the battery level of the smart key is low with the auto lock function enabled, this message is displayed for approximately 5 seconds. • If you attempt to set the auto lock function using the smart key when the battery level of the smart key is low, this message is displayed for approximately 5 seconds. • If the message is displayed, the auto lock is disabled. After replacing the smart key battery, tick the box at Door / Tailgate → Smart door auto lock under  (user settings) in the instrument cluster.
	<p>When the vehicle is charging, you cannot start it. Please start the vehicle after stopping the charging process</p>	<ul style="list-style-type: none"> • This message is displayed when the START/STOP switch is depressed while charging the battery.

Item	Message	Activation conditions
START/STOP switch warning	 <p>Press on clutch and brake pedals to start engine</p>	<ul style="list-style-type: none"> • For the vehicles with A/T, when the ignition switch is turned to ACC position a second time by pressing the ignition switch continuously without depressing the brake pedal, this message is displayed for about 5 seconds. • This message informs the driver that the vehicle can be started only if the START/STOP switch is pressed with the brake depressed.
	 <p>Shift to P</p>	<ul style="list-style-type: none"> • This message is displayed for approximately 5 seconds when starting the vehicle with the electronic gear selector lever in any position other than P (park). • This message informs the driver that the electronic gear selector lever should be in P position before pressing the START/STOP switch.
	 <p>Turn it off to prevent battery drain</p>	<ul style="list-style-type: none"> • This message is displayed for approximately 5 seconds in order to prevent the vehicle battery from being depleted when the START/STOP switch in the ACC status is maintained for 12 minutes or more or the driver seat door is opened with the START/STOP switch in the ACC status.

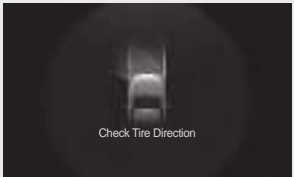
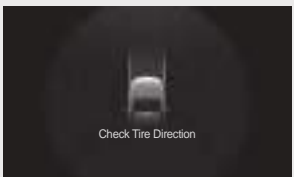
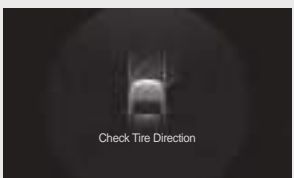

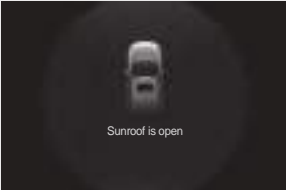
Item	Message	Activation conditions												
Front/rear obstacle detection	<p data-bbox="305 199 609 241">If it is in the R (reverse) position</p> <table border="1" data-bbox="305 246 893 711"> <tr> <td data-bbox="305 246 495 282">LV3</td> <td data-bbox="495 246 690 282">LV2</td> <td data-bbox="690 246 893 282">LV1</td> </tr> <tr> <td></td> <td></td> <td></td> </tr> <tr> <td data-bbox="305 482 495 517">LV0</td> <td data-bbox="495 482 690 517">Error</td> <td></td> </tr> <tr> <td></td> <td></td> <td></td> </tr> </table>	LV3	LV2	LV1				LV0	Error					<ul style="list-style-type: none"> • Rear PAS (Parking Assist System) (When the SBW (shift by wire) is placed in the R (reverse) position with the START/STOP switch in the ON status) <ul style="list-style-type: none"> - When you move the SBW (shift by wire) to the R (reverse) position, the warning buzzer sounds briefly once, and when an obstacle near the vehicle is detected, the position and distance from the obstacle are displayed in 4 levels (0-3). - In Level 1 of the rear PAS, the detection result of the front PAS is not displayed, and only the vehicle shape is displayed in Level 0 of the rear PAS. - When the obstacle detection sensor is abnormal, "?" is displayed for the relevant sensor.
	LV3	LV2	LV1											
														
LV0	Error													
														
<p data-bbox="305 723 609 764">If it is in the D (driving) position</p> <table border="1" data-bbox="305 770 893 1046"> <tr> <td data-bbox="305 770 495 805">LV3</td> <td data-bbox="495 770 690 805">LV2</td> <td data-bbox="690 770 893 805">Error</td> </tr> <tr> <td></td> <td></td> <td></td> </tr> </table>	LV3	LV2	Error				<ul style="list-style-type: none"> • Front PAS (Parking Assist System) (When the SBW (shift by wire) is placed in the D (drive) position with the START/STOP switch in the ON status) <ul style="list-style-type: none"> - When an obstacle is detected in front of the vehicle, the position and distance from the obstacle are displayed in level 3 and level 2, and such position and distance are not displayed in Level 1 and level 0. - The front parking assist system is not activated when the vehicle speed is 15 km/h or higher. ☞ Refer to "Parking assist system*" (p.4-175) - When the obstacle detection sensor is abnormal, "?" is displayed for the relevant sensor. 							
LV3	LV2	Error												
														



Item	Message		Activation conditions	
Display of door/ hood/tailgate opening	Driver door open	Passenger door open	<ul style="list-style-type: none"> • Displays which door is open. • When the hood or tailgate is open, the corresponding position flashes. • For vehicles with power tailgate, the tailgate opening height can be set in 10 stages. And the power tailgate indicator will be displayed according to the setting. 	
				
	Rear left door open	Rear right door open		
				
	Hood open (flashing)	Tailgate open (flashing)		
				

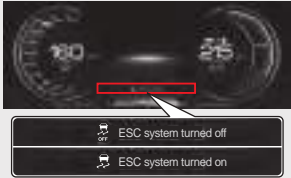
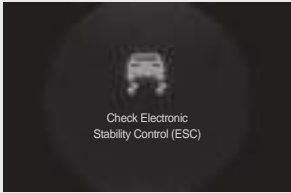
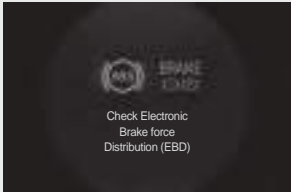
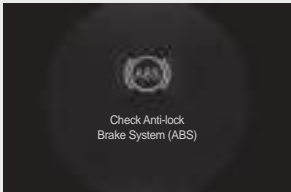

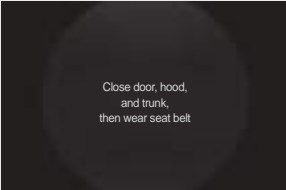
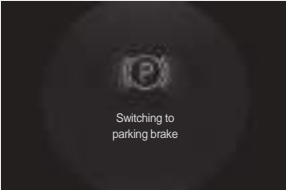

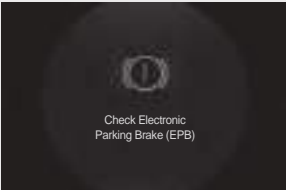
Item	Message	Activation conditions
Display of tire alignment status	<p>5 levels on the left</p>  <p>Check Tire Direction</p>	<ul style="list-style-type: none"> • This message is displayed in level 1 to 5 according to the tire alignment status when the START/ STOP switch is switched from the OFF status to the ON status. • This message is not displayed when the tire alignment status is level 0. • The message is displayed for 5 seconds up to level 2 and the message is displayed continuously until the condition is met for level 3 to 5. • This message is displayed only when the SBW (shift by wire) is in the P (parking) or the N (neutral) position.
	<p>0 level</p>  <p>Check Tire Direction</p>	
	<p>5 levels on the right</p>  <p>Check Tire Direction</p>	

Item	Message	Activation conditions
Exterior lamp ON alert		<ul style="list-style-type: none"> • This message is displayed if the exterior lamp is on when the vehicle is turned off and the driver seat door is opened.
Sunroof open warning		<ul style="list-style-type: none"> • A message will be displayed if the sunroof is open after the ignition is turned off.
SHB system warning		<ul style="list-style-type: none"> • If the SHB system is abnormal, this message is displayed 3 seconds later after the vehicle is started.
Smart tailgate indicator		<ul style="list-style-type: none"> • The smart tailgate indicator turns on when Door/Tailgate → Smart Tailgate → Enable is marked from the  (User Settings) on the instrument cluster. • The smart tailgate indicator is displayed only in the supervision type instrument cluster.

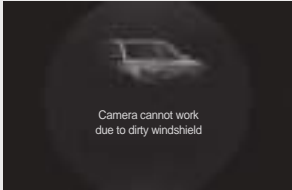
Item	Message	Activation conditions
Electronic Stability Control (ESC) ON/OFF		<ul style="list-style-type: none"> This message is displayed for approximately 5 seconds depending on the status of the ESC OFF switch.
Electronic stability control system (ESC) warning		<ul style="list-style-type: none"> If the ESC system is abnormal, the warning light turns on and this message is displayed 3 seconds after the vehicle is started.
Electronic Brake-Force Distribution (EBD) system warning		<ul style="list-style-type: none"> If the EBD system is abnormal, the warning light turns on and the message is displayed 3 seconds later after the vehicle is started.
ABS warning		<ul style="list-style-type: none"> If the ABS system is abnormal, the warning light turns on and the message is displayed 3 seconds later after the vehicle is started.





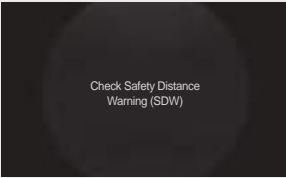

Item	Message	Activation conditions
EPB (Electronic Parking Brake)	 <p>Close door, hood, and trunk, then wear seat belt</p>	<ul style="list-style-type: none"> This message is displayed when you press the accelerator pedal with the condition for automatic release not met while the Electronic Parking Brake (EPB) is applied or the AUTO HOLD function is activated.
	 <p>Switching to parking brake</p>	<ul style="list-style-type: none"> This message is displayed when the AUTO HOLD operation status is changed to the Electronic Parking Brake (EPB) status.
	 <p>Activate brake immediately</p>	<ul style="list-style-type: none"> This message is displayed for approximately 5 seconds when the occurrence of vehicle slip or EPB failure is detected with AUTO HOLD activated. However, this message is not displayed if the Electronic Parking Brake (EPB) activated again automatically when a vehicle slip occurs, preventing the occurrence of vehicle slip.
	 <p>Check Electronic Parking Brake (EPB)</p>	<ul style="list-style-type: none"> When the Electronic Parking Brake (EPB) system is abnormal, this message is displayed and the relevant warning light blinks. If the message persists, visit a nearby KG Mobility Authorized Service Center and have your vehicle checked and serviced.

Item	Message	Activation conditions
<p>AEBS (Autonomous Emergency Braking System)</p>	 <p>Collision Warning</p>	<ul style="list-style-type: none"> • When the Autonomous Emergency Braking System (AEBS) activation condition is met, a message saying “Collision Warning” is displayed for 5 seconds. The AEBS warning light also blinks for 5 seconds. • When the system operates additionally while the message is being displayed, the same message is displayed for 5 seconds.
	 <p>Emergency Braking Off</p>	<ul style="list-style-type: none"> • This message is displayed when the vehicle has stopped by the maximum brake control operation at the time of 3rd warning of the AEBS.
	 <p>AEBS Check Autonomous Emergency Braking (AEB)</p>	<ul style="list-style-type: none"> • If the AEBS is abnormal 3 seconds later after starting the vehicle, this message is displayed for 5 seconds.
	 <p>Camera cannot work due to dirty windshield</p>	<ul style="list-style-type: none"> • If the part of the windshield where the Front Camera Module (FCM) is installed is contaminated with dust so that the lanes, preceding vehicles or people cannot be recognized, this message is displayed.

Item	Message	Activation conditions
Auto hold		<ul style="list-style-type: none"> • If the auto hold function is abnormal, the message is displayed. • If the message persists, visit a nearby KG Mobility Authorized Service Center and have your vehicle checked and serviced.
		<ul style="list-style-type: none"> • This message is displayed when you operate the EPB switch without depressing the brake pedal for deactivating the AUTO HOLD function.
Safety distance warning		<ul style="list-style-type: none"> • This function is enabled when you tick the box at Driving assistance → Safety distance warning under  (User Settings) in the instrument cluster. • The message is displayed when your vehicle is approaching the preceding vehicle.
		<ul style="list-style-type: none"> • The message is displayed if the safety distance reminder system is faulty. • If the message stays on, have the system checked and serviced at a nearest KG Mobility Authorized Service Center.



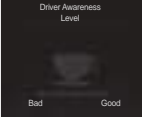
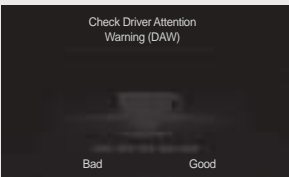

SDW (Safety Distance Warning)



Function to display the message to the driver when it is determined that safety distance is not secured by analyzing the information such as distance to front vehicle, speed and position

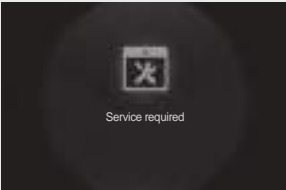

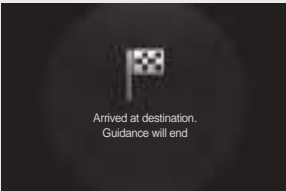
Item	Message	Activation conditions
Driver Attention Warning (DAW)		<ul style="list-style-type: none"> This message is displayed when you untick the box at Driving assistance → Driver attention alert under  (User Settings) in the instrument cluster and select main menu (Driving Assistance menu).
	 	<ul style="list-style-type: none"> The driver attention alert (DAA) displays the driver's "cautious driving level" in the 5 bars (5 levels) and if there is no bar at the bottom, the driver will be alerted with a warning message and buzzer.
	 	
	 	
		<ul style="list-style-type: none"> This message is displayed in the event of the faulty DAA system. If the message stays on, have the system checked and serviced at a nearest KG Mobility Authorized Service Center.





Driver Attention Warning (DAW)



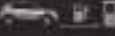

A function that warns and encourages the driver to get some rest by displaying the warning level based on the result of analyzing the vehicle information and the driver's driving pattern.



Item	Message	Activation conditions
Rest alert		<ul style="list-style-type: none"> • A message recommending taking a rest to the driver is displayed for approximately 10 seconds for safe driving when the driver has driven the vehicle for a certain period of time. • Alert interval: <ul style="list-style-type: none"> – The message is displayed every 2 hours based on initial vehicle start-up with the START/STOP switch in the ON status. – For vehicles with DAA, the warning pop-up is displayed by the DAA system.
Service interval alert		<ul style="list-style-type: none"> • When Enable service interval alert is marked from  (User Settings) on the instrument cluster and the remaining distance reaches 0 km, this message is displayed once (when the START/STOP switch is turned from OFF to ON status).
Destination arrival alert		<ul style="list-style-type: none"> • This message is displayed when navigation is interlocked with the system and the distance to the destination becomes 0 km. • In TBT mode (main menu), the pop-up message is not displayed.
Bluetooth photo call standby		<ul style="list-style-type: none"> • When you receive a phone call with the hands-free connected, the caller name or the telephone number is displayed for approximately 5 seconds. If the caller name and the telephone number are incoming at the same time, only the caller name is displayed. • In AV screen (main menu), the pop-up message is not displayed.





Item	Message	Activation conditions
1 km to the destination check		<ul style="list-style-type: none"> • This message is displayed when the remaining distance to the destination is 1 km in linkage with the navigation system. • In TBT mode (main menu), the pop-up message is not displayed.
Charging required prior to reaching the destination alert		<ul style="list-style-type: none"> • For vehicles with navigation system, this message is displayed if the remaining driving range with current SoC is less than the distance to the destination set in the navigation system. If this message is shown, charging the battery before reaching your destination is necessary.
HV battery charging required warning		<ul style="list-style-type: none"> • This message is displayed for approximately 5 seconds when the HV battery needs to be charged.

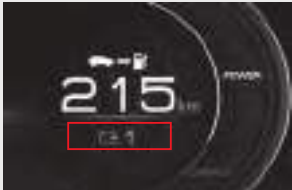

Item	Message	Activation conditions
Battery low alert	 The battery level is low	<ul style="list-style-type: none"> This message is displayed for approximately 5 seconds when the HV battery level is low.
	 The supplied power will be limited. Please charge the battery	<ul style="list-style-type: none"> This message is displayed for approximately 5 seconds when the HV battery SoC drops below 5% before the motor power is limited.
	 The supplied power will be limited	<ul style="list-style-type: none"> This message is displayed for approximately 5 seconds when the motor power is limited because of low HV battery level.
	 Charge at the closest charging station Cannot drive to the next station	<ul style="list-style-type: none"> This message is displayed for approximately 5 seconds when there is no charging stations available on route to your destination.



Item	Message	Activation conditions
auxiliary battery protection engaged alert	 <p>The 12V supplementary battery protection function is activated</p>	<ul style="list-style-type: none"> This message is displayed for approximately 5 seconds when starting the vehicle with the LV (12 V) battery protection function activated.
	 <p>Check the power supply! Park the vehicle at a safe location</p>	<ul style="list-style-type: none"> This message is displayed for approximately 5 seconds when there is a fault in the LV (12 V) battery system.
Battery temperature abnormal alert	 <p>The battery temperature is low The supplied power may be limited</p>	<ul style="list-style-type: none"> This message is displayed for approximately 5 seconds when both the temperature and SoC of the HV battery are too low.
	 <p>Danger of battery overheat! Park the vehicle at a safe location</p>	<ul style="list-style-type: none"> This message is displayed for approximately 5 seconds when the temperature of the HV battery is too high.



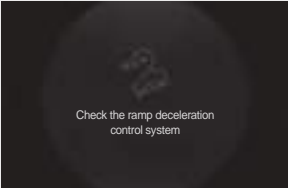

Item	Message	Activation conditions
Abnormal charging alert	 <p>Charging failed due to a malfunction in the external slow charger</p>	<ul style="list-style-type: none"> This message is displayed for approximately 5 seconds if a fault has developed in the external slow charger while charging the HV battery.
	 <p>Charging failed due to a malfunction in the external quick charger</p>	<ul style="list-style-type: none"> This message is displayed for approximately 5 seconds if a fault has developed in the external fast charger while charging the HV battery.
	 <p>Charging stopped Check the cable connection</p>	<ul style="list-style-type: none"> This message is displayed for approximately 5 seconds if a fault has developed in the charge cable while charging the HV battery.
	 <p>Charging failed due to a malfunction in the charging system</p>	<ul style="list-style-type: none"> This message is displayed for approximately 5 seconds if a fault has developed in the charging system while charging the HV battery.

Item	Message	Activation conditions
Regenerative braking level	   	<ul style="list-style-type: none">• The default setting for the regenerative braking level can be changed according to the driver requirements.• The regenerative braking level currently engaged is displayed when the regenerative braking is activated during driving.• The default setting for the regenerative braking level is Level 1 or Level 2 based on the selected drive mode. You can choose from 3 levels (Level 1 to Level 3) using the paddle shifter.

Item	Message	Activation conditions
Drive mode		<ul style="list-style-type: none"> • The drive mode changes as follows each time the mode switch is pressed, and the selected mode is displayed on the screen: ECO, COMFORT, SPORT, ECO+. • The drive mode currently selected can be identified by the backlight color of the instrument cluster display. <ul style="list-style-type: none"> – ECO, ECO+: Green – COMFORT: Blue – SPORT: Red • The drive mode will be switched between the 4 modes automatically based on the driving conditions if AUTO is set for Drive Mode under User Settings menu of the instrument cluster.
		
		
		

Item	Message	Activation conditions
Hill Descent Control (HDC) function ON/OFF	 	<ul style="list-style-type: none"> • This message is displayed for approximately 5 seconds according to the Hill Descent Control (HDC) ON/OFF status. • The color of the indicator changes according to the HDC operation status. <ul style="list-style-type: none"> – Green indicator turns on: The HDC is in ready status. – Green indicator blinks: The HDC is operating. – Red warning light turns on: The HDC system is overheated and abnormal.
HDC System		<ul style="list-style-type: none"> • If the HDC (Hill Descent Control) system is faulty, this message is displayed. • If the message stays on, have the system checked and serviced at a nearest KG Mobility Authorized Service Center.
		<ul style="list-style-type: none"> • If the operating conditions of the HDC system are not met, this message is displayed.



Item	Message	Activation conditions
Light mode	 <p>The image shows a close-up of the instrument cluster's central display. A red box highlights the 'Light Mode' menu. Below the cluster, a separate menu is shown with four options: 'Light Mode AUTO' (with a sun icon), 'Light Mode' (with a sun and beam icon), 'Light Mode' (with a sun and beam icon), and 'Light Mode OFF' (with a sun icon).</p>	<ul style="list-style-type: none"> The current status among 4 modes is displayed for approximately 5 seconds according to the position of the light switch.
Windshield wiper mode	 <p>The image shows a close-up of the instrument cluster's central display. A red box highlights the 'Front Wiper Mode' menu. Below the cluster, a separate menu is shown with four options: 'Front Wiper Mode Auto' (with a wiper icon), 'Front Wiper Mode Low' (with a wiper icon), 'Front Wiper Mode High' (with a wiper icon), and 'Front Wiper Mode Off' (with a wiper icon).</p>	<ul style="list-style-type: none"> The current status of the windshield wiper among 4 modes is displayed for approximately 5 seconds according to the position of the wiper operation lever.
Rear window wiper mode	 <p>The image shows a close-up of the instrument cluster's central display. A red box highlights the 'Rear Wiper Mode' menu. Below the cluster, a separate menu is shown with three options: 'Rear Wiper Mode Low' (with a wiper icon), 'Rear Wiper Mode High' (with a wiper icon), and 'Rear Wiper Mode Off' (with a wiper icon).</p>	<ul style="list-style-type: none"> The current status of the rear window wiper among 3 modes is displayed for approximately 5 seconds according to the position of the rear window wiper operation lever.

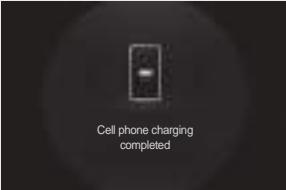
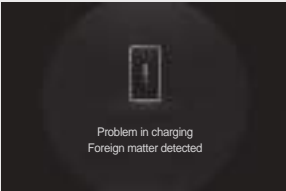
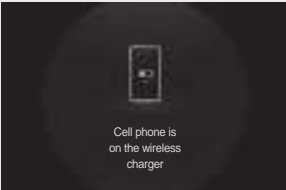

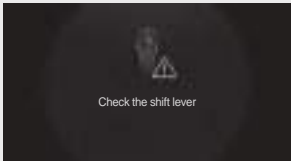
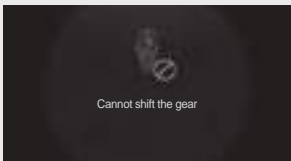
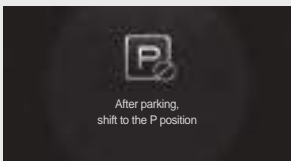
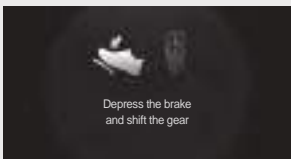
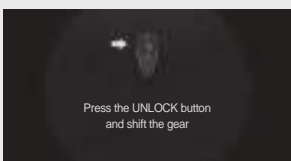
Item	Message	Activation conditions
AV volume level	 	<ul style="list-style-type: none"> The current AV volume level is displayed for approximately 5 seconds when adjusting the volume level.
Steering wheel heater	 	<ul style="list-style-type: none"> The message is displayed for 5 seconds according to the steering wheel heater ON/OFF status with the START/STOP switch in the ON status or with the vehicle started.

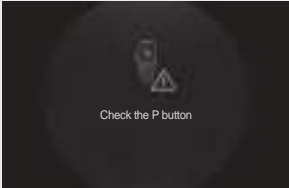
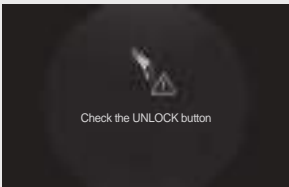

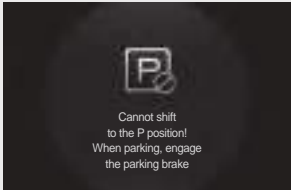
Item	Message	Activation conditions
Reminder from wireless phone charger	 <p>Cell phone charging</p>	<ul style="list-style-type: none"> If any phone is on the wireless charging pad after the ignition is off (ignition switch in ACC or OFF position) while the wireless phone charger is operating with the ignition switch in ON position, a reminder message "The phone is on the wireless phone charger." is displayed on the instrument cluster. (However, reminder does not work when changing the ignition switch from the OFF position to ACC position even if the wireless phone charger is operating.)
	 <p>Cell phone charging completed</p>	<ul style="list-style-type: none"> When the wireless phone charger system is working normally to start charging your phone, this message is displayed on the instrument panel for about 5 seconds.
	 <p>Problem in charging Foreign matter detected</p>	<ul style="list-style-type: none"> This message is displayed on the instrument panel for about 5 seconds when the charging is completed.
	 <p>Cell phone is on the wireless charger</p>	<ul style="list-style-type: none"> If there is a problem with charging or there is a metal object on the charging pad, this message is displayed on the instrument panel for 5 seconds at approximately 5 minute intervals. If your phone doesn't charge, try to lift the phone off the charging pad and place it again or check your phone condition. (Your phone may stop charging depending on battery temperature conditions.) In addition, be sure to remove any metallic object on the wireless charging pad.

Item	Message	Activation conditions
Shift Lever (SBW)	 <p>Check the shift lever</p>	<ul style="list-style-type: none"> • If there is a fault in the SBW system, this message is displayed. • If the message stays on, have the system checked and serviced at a nearest KG Mobility Authorized Service Center.
	 <p>Cannot shift the gear</p>	<ul style="list-style-type: none"> • If the current status of the vehicle does not meet the SBW system's shifting conditions, this message is displayed.
	 <p>After parking, shift to the P position</p>	<ul style="list-style-type: none"> • If the vehicle is not completely stopped and the P (park) button is pressed, a corresponding message is displayed.
	 <p>Depress the brake and shift the gear</p>	<ul style="list-style-type: none"> • When the electronic shift lever (SBW) is operated, the message is displayed if the shift lever is operated without the brake applied.
	 <p>Press the UNLOCK button and shift the gear</p>	<ul style="list-style-type: none"> • When the electronic shift lever (SBW) is operated, the message is displayed if the shift lever is operated without pressing the UNLOCK button.

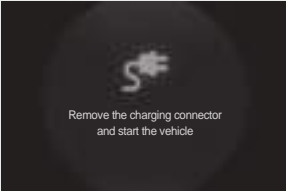
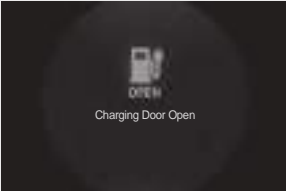
Item	Message	Activation conditions
Shift Lever (SBW)	 <p>Check the P button</p>	<ul style="list-style-type: none"> • If there is a fault in the SBW button, this message is displayed. • If the message stays on, have the system checked and serviced at a nearest KG Mobility Authorized Service Center.
	 <p>Check the UNLOCK button</p>	



Item	Message	Activation conditions
EV gear shift alert	 <p>When the vehicle is charging, you cannot start it. Please start the vehicle after stopping the charging process</p>	<ul style="list-style-type: none"> • This message is displayed when the START/STOP switch is depressed while charging the battery.
	 <p>Cannot shift to the P position! When parking, engage the parking brake</p>	<ul style="list-style-type: none"> • This message is displayed for approximately 5 seconds when the electronic gear selector lever (shift by wire) can't be shifted into P (park) position.
	 <p>Check the electronic gear shift system</p>	<ul style="list-style-type: none"> • This message is displayed for approximately 5 seconds when there is a fault in the electronic gear selector lever (SBW).

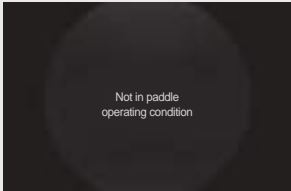

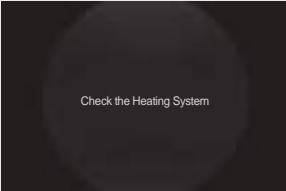
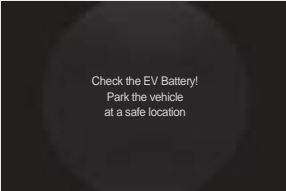

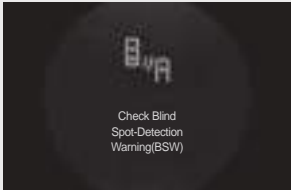
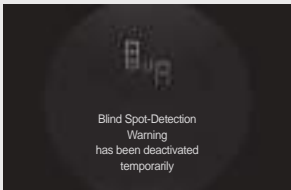

Item	Message	Activation conditions
EV gear shift alert		<ul style="list-style-type: none"> If the vehicle is started by pressing the ignition switch while the charging connector is connected, a corresponding message will be displayed.
		<ul style="list-style-type: none"> This message is displayed when the open charge port door is detected after starting the vehicle.
Remaining charging time		<ul style="list-style-type: none"> When the HV battery is charging with the START/STOP switch ON, the system displays the charging status information including the time remaining until fully charged.
Virtual engine sound system alert		<ul style="list-style-type: none"> This message is displayed for approximately 5 seconds when there is a fault in the virtual engine sound system (VESS).

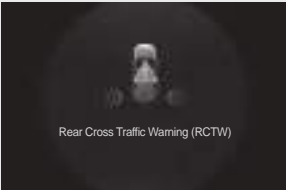
Item	Message	Activation conditions
EV system alert		<ul style="list-style-type: none"> • This message is displayed for approximately 5 seconds when there is a fault in the high-voltage electronic system.
Vehicle READY indicator		<ul style="list-style-type: none"> • When the vehicle is started, this message is displayed for approximately 5 seconds if the vehicle is ready to drive.
Paddle shifter		<ul style="list-style-type: none"> • This message is displayed for approximately 5 seconds if you operate the paddle shifter to change the regenerative braking level while the operating conditions are not met.

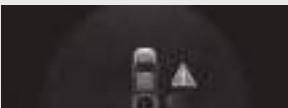

Item	Message	Activation conditions
Heating system alert		<ul style="list-style-type: none"> • This message is displayed for approximately 5 seconds when there is a fault in the EV heating system.
Drive battery alert		<ul style="list-style-type: none"> • This message is displayed for approximately 5 seconds when there is a fault in the HV battery.

Item	Message	Activation conditions
BSW (Blind Spot Warning) system	 <p>The image shows a close-up of the instrument cluster. At the top, there is a red bar with a white arrow pointing to it. Below this, there are two rectangular boxes. The first box contains a white exclamation mark in a circle followed by the text "Blind Spot-Detection Warning Off". The second box contains a white exclamation mark in a circle followed by the text "Blind Spot-Detection Warning On".</p>	<ul style="list-style-type: none"> This message is displayed for approximately 5 seconds according to the ON/OFF status of rear and side warning system.
	 <p>The image shows a dark screen with the text "Check Blind Spot-Detection Warning (BSW)" in white. Above the text, there are faint, stylized letters "B" and "A" on either side.</p>	<ul style="list-style-type: none"> If the rear and side warning system is abnormal, this message is displayed. If the message persists, visit a nearby KG Mobility Authorized Service Center and have your vehicle checked and serviced.
	 <p>The image shows a dark screen with the text "Blind Spot-Detection Warning has been deactivated temporarily" in white. Above the text, there are faint, stylized letters "B" and "A" on either side.</p>	<ul style="list-style-type: none"> This message is displayed if the sensor cannot detect the rear, left and right sides with the rear and side warning system activated. (When there are foreign materials on the outside or inside of the rear bumper, a trailer or other equipment is installed in the rear of the vehicle, the width of the road is wide, it snows or rains too much and etc.)

Item	Message	Activation conditions
Rear Cross Traffic Warning (RCTW) system		<ul style="list-style-type: none"> The message will be displayed for about 5 seconds depending on the ON / OFF status of the BSW system.
	 <p>Rear Cross Traffic Warning (RCTW)</p>	<ul style="list-style-type: none"> If an object is approaching the rear left, rear right or both sides of the vehicle with the RCTW system activated, the relevant warning is displayed.
	 <p>Rear Cross Traffic Warning (RCTW)</p>	
 <p>Rear Cross Traffic Warning (RCTW)</p>		

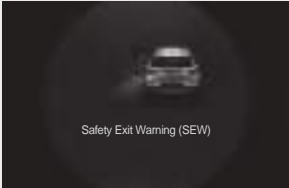
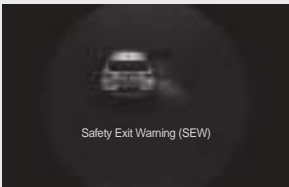
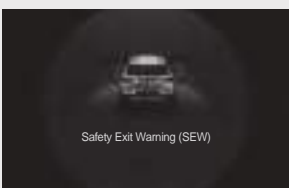

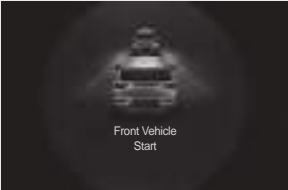

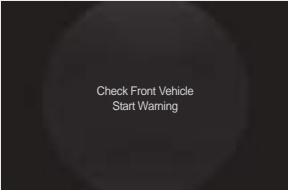
Item	Message	Activation conditions
Rear Cross Traffic-Collision Assist (RCTA)	  	<ul style="list-style-type: none"> The message will be displayed for about 5 seconds depending on the ON / OFF status of the RCTA system.
	 Press brake pedal	<ul style="list-style-type: none"> If, the risk of collision is detected due to an approaching vehicle during operation of the RCTA system, emergency braking (braking assistance) is performed while the corresponding alarm is displayed.
	 Press brake pedal	
	 Press brake pedal	





Item	Message	Activation conditions
Safety exit warning (SEW)		<ul style="list-style-type: none"> If you are about to open the door to leave the vehicle when a vehicle is approaching from the rear side, the vehicle exit alert system displays a message and generates a beep sound. However, it operates only when the SBW (shift by wire) is in P (park) or N (neutral) position.
		
		





Item	Message	Activation conditions
Front vehicle start warning (FVSW)	 <p>Front Vehicle Start</p>	<ul style="list-style-type: none"> This function is enabled when you tick the box at Driving assistance → Front vehicle start alarm under  (User Settings) in the instrument cluster. <div style="border: 1px solid black; background-color: #ffe6e6; padding: 5px; text-align: center;">  Caution </div> <ul style="list-style-type: none"> The FVSW does not work in stop situations other than stop by the brake pedal, auto hold, or smart cruise control system. If you stop the vehicle with shift lever in N (neutral) position, it may not operate or may generate a false alarm. In an environment other than the normal driving situation (non-motorway / highway), it may generate a false alarm. The FVSW works only when the shift lever is in D (drive) or N (neutral) position.
	 <p>Check Front Vehicle Start Warning</p>	<ul style="list-style-type: none"> If there is a fault in the FVSA system, this message is displayed. If the message stays on, have the system checked and serviced at a nearest KG Mobility Authorized Service Center.



Front Vehicle Start Warning (FVSW)





A function to emit a buzzer and display a message if the driver does not depart the vehicle after the front vehicle has departed and moved a certain distance



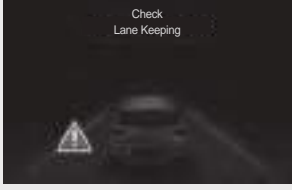

Item	Message	Activation conditions
LDW (Lane Departure Warning)	 <p>Lane Warning Off</p>	<ul style="list-style-type: none"> • Displayed when the lane departure warning system is disabled.
	 <p>Lane Warning Standby</p>	<ul style="list-style-type: none"> • The lane marker is shaded when the vehicle is driven at less than 40 kph (low speed conditions) or more than 155 kph (high speed conditions), or both lane lines are not detected.
	 <p>Lane Warning Error</p>	<ul style="list-style-type: none"> • This message is displayed when the LDW is unavailable.
	 <p>Check Lane Warning</p>	<ul style="list-style-type: none"> • This message is displayed and remains on when LDW is not functioning properly. • This message pops up 3 sends after the vehicle is started, when LDW is not functioning properly. • If the message stays on, have the vehicle checked and serviced at the nearest KG Mobility Dealer or KG Mobility Authorized Service Center.





Item	Message	Activation conditions
LDW lane display area	 <p>Lane Warning System</p>	<ul style="list-style-type: none"> When only the left lane line is detected, the left lane marker on the display turns green (without pop-up message).
	 <p>Lane Warning System</p>	<ul style="list-style-type: none"> If your vehicle approach the left lane line without activating the turn signal lamp or with the right turn signal on, provided that only the left lane line is detected, the corresponding lane marker on the display will blink (green ↔ red).
	 <p>Lane Warning System</p>	<ul style="list-style-type: none"> When only the right lane line is detected, the right lane marker on the display turns green (without pop-up message).
	 <p>Lane Warning System</p>	<ul style="list-style-type: none"> If your vehicle approach the right lane line without activating the turn signal lamp or with the left turn signal on, provided that only the right lane line is detected, the corresponding lane marker on the display will blink (green ↔ red).



Item	Message	Activation conditions
LDW lane display area		<ul style="list-style-type: none"> When both lane lines are detected, both the lane markers on the display turns green. (no pop-up message is displayed.)
		<ul style="list-style-type: none"> If both lane lines are detected and your vehicle approach either side of the lane without turning on the corresponding turn signal lamp, the corresponding lane marker on the display will blink (green ↔ red).
		<ul style="list-style-type: none"> Please keep in mind that the you should activate the turn signal lamp on the same side of the lane as where the vehicle is approaching.
		

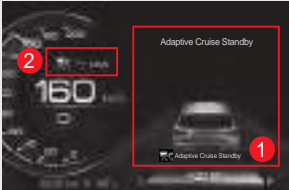

Item	Message	Activation conditions
LKA (Lane Keeping Assist)		<ul style="list-style-type: none"> • Displayed when the lane keeping assistance system is disabled.
		<ul style="list-style-type: none"> • The lanes are shaded when the vehicle is driven at a low speed of less than 40 kph or at a high speed of 155 kph or higher or both lanes are not detected.
		<ul style="list-style-type: none"> • Displayed when the lane keeping assistance system is disabled.
		<ul style="list-style-type: none"> • Displayed as pop-up message 3 seconds after the start-up when there is a fault in the lane keeping assistance system. • If the message stays on, have the system checked and serviced at a nearest KG Mobility Authorized Service Center.

Item	Message	Activation conditions
LKA lane display area	 <p>Lane Keeping System</p>	<ul style="list-style-type: none"> When only the left lane line is detected, the left lane marker on the display turns green. (no pop-up message is displayed.)
	 <p>Lane Keeping System</p>	<ul style="list-style-type: none"> For vehicles with LKA system, turning on a turn signal lamp deactivates the LKA.
	 <p>Lane Keeping System</p>	<ul style="list-style-type: none"> When only the right lane line is detected, the right lane marker on the display turns green. (no pop-up message is displayed.)
	 <p>Lane Keeping System</p>	<ul style="list-style-type: none"> For vehicles with LKA system, turning on a turn signal lamp deactivates the LKA.

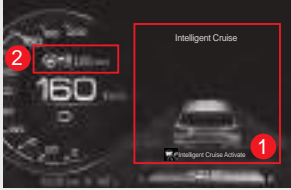
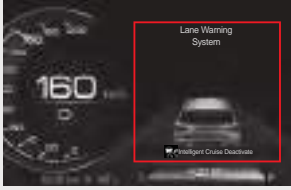

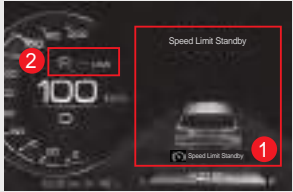

Item	Message	Activation conditions
LKA lane display area	 <p>Lane Keeping System</p>	<ul style="list-style-type: none"> When both lane lines are detected, both the lane markers on the display turns green. (no pop-up message is displayed.)
	 <p>Lane Keeping System</p>	<ul style="list-style-type: none"> For vehicles with LKA system, turning on a turn signal lamp deactivates the LKA.
	 <p>Lane Keeping System</p>	
	 <p>Lane Keeping System</p>	

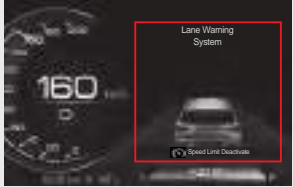

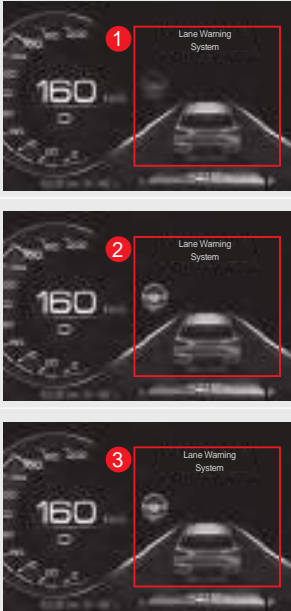

Item	Message	Activation conditions
Adaptive cruise control (ACC)		<ul style="list-style-type: none"> When you press the cruise control ON/OFF switch with the START/STOP switch ON, "Adaptive cruise standby" message (1) and the symbol (2) are displayed indicating that the adaptive cruise control (ACC) system is ready to use.
		<ul style="list-style-type: none"> If you pull down the speed control lever when the ACC is ready, "Adaptive cruise activate" message (1), the symbol and set speed (2) are displayed; and the ACC system is engaged. If there is no vehicle ahead, the vehicle keeps cruising at the set speed. If there is a vehicle ahead of you and your vehicle is being driven at a speed lower than the set speed, the ACC continues to maintain the set distance from the vehicle ahead.
		<ul style="list-style-type: none"> If you disengage the ACC during its operation (ready/auto), "Adaptive cruise deactivate" message is displayed and the ACC is disengaged.
		



Item	Message	Activation conditions
Intelligent cruise control (iACC) (with radar)		<ul style="list-style-type: none"> When you press the cruise control ON/OFF switch with the START/STOP switch ON, "Intelligent cruise standby" message (1) and the symbol (2) are displayed indicating that the intelligent cruise control (IACC) system is ready to use. (IACC should be enabled in the settings for the system to be functional)
		<ul style="list-style-type: none"> If you pull down the speed control lever when the IACC is ready, "Intelligent cruise activate" message (1), the symbol and set speed (2) are displayed; and the IACC system is engaged. If there is no vehicle ahead, the vehicle keeps cruising at the set speed. If there is a vehicle ahead of you and your vehicle is being driven at a speed lower than the set speed, the IACC continues to maintain the set distance from the vehicle ahead.
		<ul style="list-style-type: none"> If you disengage the IACC during its operation (ready/auto), "Intelligent cruise deactivate" message is displayed and the IACC is disengaged.
		

Item	Message	Activation conditions
TSW (Speed Limit Warning)	 <p>The image shows a speedometer with '100' displayed. A red box labeled '2' highlights the '100' on the speedometer. Another red box labeled '1' highlights the 'Speed Limit Standby' text and a car icon on the central display.</p>	<ul style="list-style-type: none"> When you press the speed limit control ON/OFF switch with the START/STOP switch ON, "Speed limit standby" message (1) and symbol (2) are displayed and the speed limit is ready to use.
	 <p>The image shows a speedometer with '100' displayed. A red box labeled '2' highlights the '100' on the speedometer. Another red box labeled '1' highlights the 'Speed Limit Activate' text and a car icon on the central display.</p>	<ul style="list-style-type: none"> If you pull down the cruise speed control lever with the speed limit ready, "Speed limit activate" message (1), symbol and set speed (2) are displayed; and speed limit is functioning. Adjust the vehicle speed by pushing up or pulling down the cruise speed control lever.
	 <p>The image shows a speedometer with '160' displayed. A red box labeled '1' highlights the 'Speed Limit Deactivate' text and a car icon on the central display.</p>	<ul style="list-style-type: none"> If you disable the speed limit during its operation (ready/set), "Speed limit deactivate" message is displayed and the speed limit control is disabled.

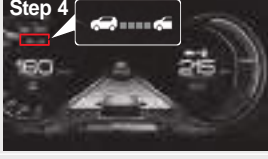

Item	Message	Activation conditions
Intelligent cruise control (iACC) steering assist control	 <p>The message 'Lane Warning System' is displayed on the instrument cluster. The first image (1) shows the system in ready mode. The second image (2) shows the system set. The third image (3) shows the system activated while driving in the center of the lane.</p>	<ul style="list-style-type: none"> • The steering assist symbol is displayed in 3 steps (Ready to set, Set, and Activated) depending on the operating state of the intelligent cruise control. <ul style="list-style-type: none"> – Step 1 (1) : When the intelligent cruise control is in ready mode in the driver assistance main menu – Step 2 (2) : When the intelligent cruise control is set – Step 3 (3) : When driving while maintaining the center of the lane with the intelligent cruise control set



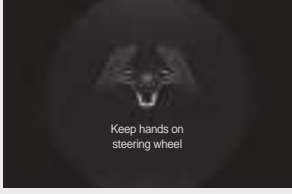
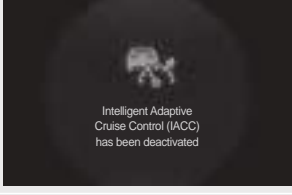
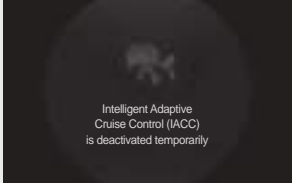

Item	Message	Activation conditions
Adaptive/intelligent cruise control distance indicator (the vehicle ahead not shown)		<ul style="list-style-type: none"> • When you press the safety distance set button with the intelligent cruise control activated, the corresponding message is displayed while the setting is shifted by one step as an order of step 5 → step 4 → step 3 → step 2 → step 1 → step 5. • This is also the same as when intelligent cruise control is in operation, and a circular symbol appears on the driver's vehicle.
		
		
		
		

Item	Message	Activation conditions
<p>Adaptive/intelligent cruise control distance indicator (the vehicle ahead shown)</p>	 <p>Step 1</p>	<ul style="list-style-type: none">• When you press the safety distance set button with the intelligent cruise control activated, the corresponding message is displayed while the setting is shifted by one step as an order of step 5 → step 4 → step 3 → step 2 → step 1 → step 5. At this time, the front vehicle is also displayed on the message.• This is also the same as when intelligent cruise control is in operation, and a circular symbol appears on the driver's vehicle.
	 <p>Step 2</p>	
	 <p>Step 3</p>	
	 <p>Step 4</p>	
	 <p>Step 5</p>	

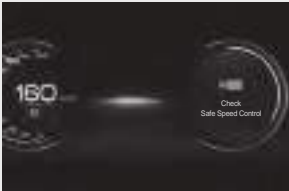
Item	Message	Activation conditions
Center lane keeping assist (CLKA) hands-off	 <p>Keep hands on steering wheel</p>	<ul style="list-style-type: none"> If the system determines that the driver does not hold the steering wheel with the lane keeping assist (LKA) system activated, a message is displayed as the stage 1 warning.
	 <p>Keep hands on steering wheel</p>	<ul style="list-style-type: none"> When a certain period of time has elapsed after the stage 1 warning, the message and beep are given continuously as the stage 2 warning.
	 <p>Lane Keeping Assist (LKA) has been deactivated</p>	<ul style="list-style-type: none"> After the stage 2 warning, for safe operation, the LKAS is disabled and the relevant message is displayed.

Item	Message	Activation conditions
Intelligent cruise control hands-off	 <p>Keep hands on steering wheel</p>	<ul style="list-style-type: none">• If the system determines that the driver does not hold the steering wheel with the intelligent cruise control system activated, a message is displayed as the stage 1 warning.
	 <p>Keep hands on steering wheel</p>	<ul style="list-style-type: none">• When a certain period of time has elapsed after the stage 1 warning, the message and beep are given as the stage 2 warning.
	 <p>Intelligent Adaptive Cruise Control (IACC) has been deactivated</p>	<ul style="list-style-type: none">• After the stage 2 warning, for safe operation, the intelligent cruise control system is disabled and the relevant message is displayed.
	 <p>Intelligent Adaptive Cruise Control (IACC) is deactivated temporarily</p>	

Item	Message	Activation conditions
		<ul style="list-style-type: none"> When the over speed warning signal is received from the navigation while the safety speed control system is operating, the corresponding symbol (1) is displayed and the safe speed control enters standby mode. However, the safety speed control display works only on highway driving.
Safety speed assist		<ul style="list-style-type: none"> When the safety speed control system automatically decelerates the vehicle, the corresponding symbol (2) is displayed and safety speed control is enabled. However, the safety speed control display works only on highway driving.
		<ul style="list-style-type: none"> This message is displayed in the event of the faulty safety speed control system. If the message stays on, have the system checked and serviced at a nearest KG Mobility Authorized Service Center.

Item	Message	Activation conditions
Adaptive cruise control alert pop-up	 <p>Forward Collision Warning</p>	<ul style="list-style-type: none"> This message is displayed when the vehicle ahead is no longer detected, for example due to lane changes, while the ACC is operating.
	 <p>When front vehicle departs, operate RES, SET button or pedal</p>	<ul style="list-style-type: none"> If the vehicle comes to a stop while the ACC is operating and the ACC system holds your vehicle at a standstill for a certain amount of time, you will be prompted to depress the accelerator pedal or push up/pull down the cruise control lever in order to start the vehicle.
	 <p>Front Vehicle Approach Warning</p>	<ul style="list-style-type: none"> This message is displayed when the distance between the driver's vehicle and the vehicle ahead decreases while the ACC is operating.
	 <p>Driver Accelerating</p>	<ul style="list-style-type: none"> This message is displayed when the accelerator pedal is depressed while the ACC is operating.

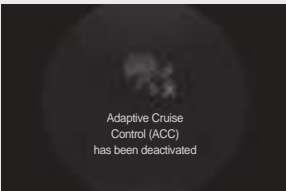
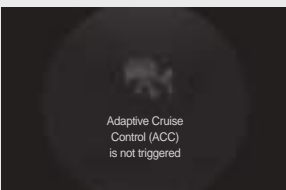
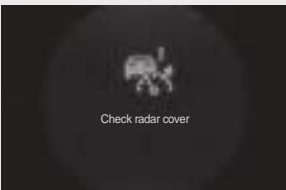
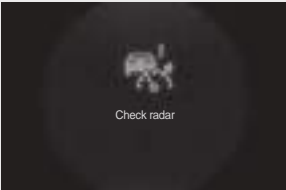
Item	Message	Activation conditions
Adaptive cruise control alert pop-up	 <p>Adaptive Cruise Control (ACC) has been deactivated</p>	<ul style="list-style-type: none"> This message is displayed when the ACC is automatically disengaged.
	 <p>Adaptive Cruise Control (ACC) is not triggered</p>	<ul style="list-style-type: none"> This message is displayed if you try to activate the ACC when the operating conditions for the system are not meet.
Adaptive cruise control check pop-up	 <p>Check radar cover</p>	<ul style="list-style-type: none"> A message is displayed when the front part of the radar cover is contaminated due to dust, dirt or other materials and can't detect the lane, preceding vehicle or people, etc.
	 <p>Check radar</p>	<ul style="list-style-type: none"> This message is displayed in the event of the faulty radar system. If the message stays on, have the system checked and serviced at a nearest KG Mobility Authorized Service Center.

Instrument cluster illumination brightness

To adjust instrument cluster illumination brightness

The instrument cluster illumination can be adjusted in 20 steps by pressing the instrument cluster illumination control switch with the ignition switch turned on.

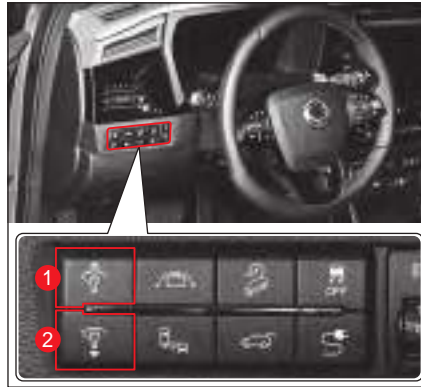

- 1 To make brighter
- 2 To make darker

- Each time you press the instrument cluster illumination control switch briefly, brightness will lighten or darken by 1 step.
- When you press and hold the instrument cluster illumination control switch, brightness will lighten or darken by 1 step every about 0.2 second.

Notice

- If the ignition switch is cycled off and on, the instrument cluster illumination remains at the previously set brightness.

SBW (shift by wire)



- 1 Electronic shift lever
- 2 P (park) button
- 3 Lever position (gear) indicator
- 4 UNLOCK button

Warning

- When changing the selector lever position, check the current position (indicator) of the selector lever on the gear position display and on the electronic shift lever display in the instrument cluster.
- When operating the electronic shift lever, be sure to press the UNLOCK button while depressing the brake pedal and operate the lever.

Transmission selector lever position

- P: Parking
- R: Reverse
- N: Neutral
- D: Drive (automatic shift)

When changing the selector lever position, you can check the current position of the selector lever on the gear position display and on the electronic shift lever display in the instrument cluster.

How to move shift lever to target gear position



The electronic shift lever can be moved at + 2 step and - 2 step, after which it is always aligned to the central position.

Notice
<ul style="list-style-type: none"> When moving to the P (park) position, press the P (park) button with the brake pedal depressed at each position.

		P position → R, N and D positions			R position → N and D position		N position → R and D positions			D position → R and D positions		
Target gear position		R	N	-	-	-	R	-	-	R	N	
Shifting lever	+2 step	↑	-	-	-	-	↑	-	-	↑	-	
	+1 step	↑	↑	-	-	-	↑	-	-	↑	↑	
	Current gear position	P position			R position		N position			D position		
	-1 step	-	-	↓	↓	↓	-	↓	↓	↓	-	-
	-2 step	-	-	↓	-	↓	-	↓	↓	-	-	
Target gear position		-	-	D	N	D	-	D	D	-	-	
Vehicle conditions	UNLOCK switch											
	Brake pedal				-				-			-
	Vehicle speed	0km/h or lower	0km/h or lower	0km/h or lower	-	8km/h or lower	-	8km/h or lower	8km/h or higher	8km/h or lower	-	

Functions for each shift position

P (park) position



Select this position to park, start the vehicle, warm-up, and stop the vehicle for a long time.

- Be sure to depress the brake pedal and press the P (park) button when moving to P (park) position from a position other than P (park).
- If the ignition switch is turned off in a position other than P (park), the shift lever automatically moves to the P (park) position.

Warning

- When moving from the P (park) position to another position, make sure that the ignition switch is turned on and the brake pedal is depressed. Do not apply excessive force to the electronic shift lever with the electronic shift lever in the P (park) position. This may lead to damage to the lever and transmission.
- Never move the shift lever to the P (park) position while driving. There is a risk of mechanical damage and accidents. Move the shift lever to the P (park) position after the vehicle has come to a complete stop.
- When you shift the transmission into P (Park) position, the parking brake automatically engages.

R (reverse) position

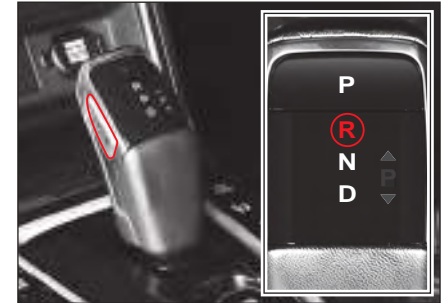

Use this position to reverse the vehicle.

When moving to the R (reverse) position, apply the brake pedal and operate the shift lever while pressing the UNLOCK button after the vehicle has come to a complete stop.

The parking aid system operates when the electronic shift lever is placed in the R (reverse) position.

Warning

- Do not shift into R position when the vehicle is moving forward. This may cause a shift shock and damage the transmission.
- If the electronic shift lever is placed in the R (reverse) position, the vehicle moves backward slowly without depressing the accelerator pedal, so drive carefully while pressing the brake pedal.

N (neutral) position



This is the neutral position where no power is transmitted.

At this position, the vehicle does not transfer power to the wheels and the vehicle will not move on level ground. However, be sure to depress the brake pedal for safety when stopping the vehicle with the electronic shift lever in the N (neutral) position.

Warning

- Do not move the electronic shift lever from D (drive) to N (neutral) or N (neutral) to D (drive) when the vehicle is moving.
- Be sure to depress the brake pedal when stopping the vehicle on a slope with the electronic shift lever in the N (neutral) position.
- Never move the shift lever to the N (neutral) position while driving.

D (drive) position



Select this position for driving on public roads and highways.

The system automatically selects the most desirable gear based on the vehicle speed and how far the throttle pedal is depressed. It also automatically activates the regenerative braking system according to the road conditions.

Notice

- The regenerative braking level can be changed based on the selected drive mode (ECO, ECO+, COMFORT, SPORT).

Warning

- If the electronic shift lever is placed in the D (drive) position, the vehicle moves forward slowly without depressing the accelerator pedal, so drive carefully.
- Do not move the shift lever to the D (drive) position until the vehicle has come to a complete stop. The decelerator damage may occur.
- Do not abruptly drive off or sharply accelerate the vehicle after moving the electronic shift lever into D (drive) position. In particular, when leaving after parking or stopping on a slope, move the shift lever to the D (drive) position with the brake pedal pressed, then wait for a few seconds for power to be transmitted inside the decelerator before starting off slowly.
- Even though the electronic shift lever is in D (drive) position, the vehicle can move down on a uphill even according to gradients, so you have to depress the brake pedal.

Regenerative braking system

Regenerative braking control (paddle shifter)

The regenerative braking system converts the braking energy into the electrical energy and stores it in the HV battery for use later on. You can change the regenerative braking level using the paddle shifter.

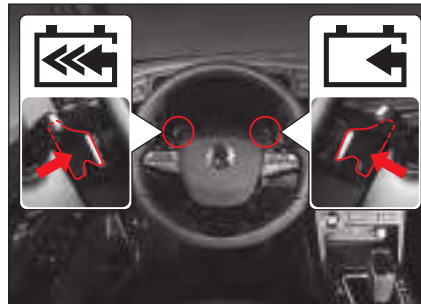

- To change the regenerative braking level (Level 1 to Level 3), pull on the desired paddle shifter behind the steering wheel on both sides with the electronic shift lever in D (drive) position.
 - Left (⏪): increases the regenerative braking level
 - Right (⏩): decreases the regenerative braking level
- Briefly pulling the paddle shifter increases or decreases the regenerative braking level by 1.

Caution

- The regenerative braking level cannot be changed when decelerating the vehicle by depressing the brake pedal or while the IACC is operating.

The regenerative braking warning light and regenerative braking level (Level 1 to Level 3) indicator are displayed on the instrument panel.

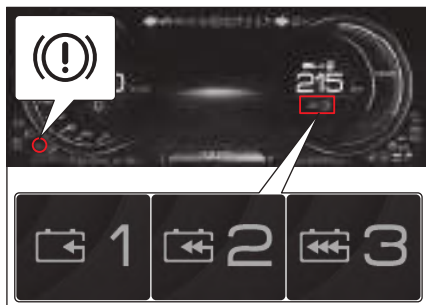

- ☞ Refer to “Regenerative braking warning light” (p.4-24)
- ☞ Refer to “Base Brake System (BBS) warning light” (p.4-25)

Regenerative braking settings

The default setting of the regenerative braking level for each drive mode can be changed to the driver's desire.

Drive Mode	Default settings	User settings available
COMFORT	Level 2	Level 0 to Level 3
SPORT		
ECO	Level 1	
ECO+		

Notice

- Move to  (User Settings) and select the item **Regenerative Braking Level** → **COMFORT / SPORT / ECO / ECO+** and then choose the desired level (**Level 1 / Level 2 / Level 3**).

Warning

- **Never charge the battery over 90% SOC in high altitudes such as mountainous areas.**
- **When driving downhill after fully charging the battery, braking may be delayed due to the inability of regenerative braking.**

Operation of EV

- 1 Start the vehicle with the electronic shift lever in P (park) position and the brake pedal depressed.
 - 2 Make sure the vehicle is running and move the electronic shift lever to the D (drive) or R (reverse) position without releasing the brake pedal.
 - 3 Release the parking brake and drive off slowly after releasing the brake pedal.
- ☞ Refer to “To start vehicle” (p.4-3)
- ☞ Refer to “Getting your vehicle started” (p.4-3)



Warning

- Do not depress the accelerator pedal when starting the vehicle. The vehicle may move suddenly and can cause accidents.
- The vehicle can be started with the electronic shift lever in N (neutral) position. But for safety, always start the vehicle when the shift lever is in P (park) position.
- Do not abruptly drive off or sharply accelerate the vehicle after moving the electronic shift lever from P (park) to D (drive) or R (reverse) position. Always make sure that the shift lever position displayed on the instrument cluster is also changed and then drive off slowly. This is especially important when driving off on a slope after parking or stopping.



Warning

- If the vehicle moves in the opposite direction of intended travel on a slope, the vehicle may shut down abruptly and braking performance of the vehicle can be degraded.
- The vehicle on a steep hill may move in the opposite direction of intended travel, even under the creeping condition. Do not release the brake pedal when stopping on a slope.
- The vehicle parked on a slope may roll slightly even if the electronic shift lever is in the D (drive) or R (reverse) position.
- For safety, do not release the brake pedal while shifting the electronic shift lever.
- Do not depress the accelerator pedal while moving the electronic shift lever.
- Be sure to depress the brake pedal and apply the parking brake when stopping the vehicle on a slope.
- Never move the electronic shift lever to the N (neutral) position while driving. The operation of regenerative braking will be prohibited by doing so. Failure to follow this warning also can result in an unexpected serious accident.
- Never charge the SOC of a high voltage battery above 90% in high altitudes, such as in mountainous areas.
- When driving downhill after fully charging the high voltage battery, the regenerative braking system may not work. This may cause braking slippage during downhill driving, so be sure to drive at a low speed.

Notice

- Allow the vehicle to creep forward by simply releasing the brake pedal before depressing the accelerator pedal slowly to drive off.
- Moving the electronic shift lever when a load is applied to the drive system (stopping or parking on a hill, etc.) may cause shift shock or noise. This is a natural mechanical reaction, and the system is normal.

What is creep?

This is a phenomenon in which the vehicle moves forward or backward without depressing the accelerator, provided that the electronic shift lever is in any position other than P or N.

You can easily maneuver the vehicle or control the vehicle speed smoothly in a heavy traffic or in a tight space by taking advantage of this characteristic.

Drive mode

Drive mode switch

Pressing the drive mode switch in normal driving condition will toggle the drive mode as follows:

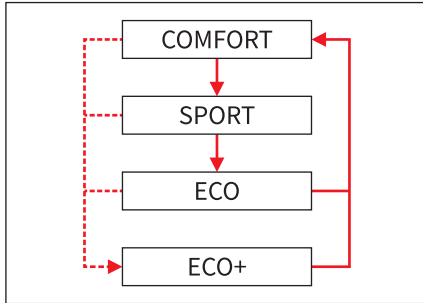

Long press:

Short press:



Default settings for each mode

Drive mode		COMFORT	SPORT	ECO	ECO+
Driving style		Normal driving	Sporty driving	Economical driving	Extreme power saving
Switch operation		Default	Short press	Short press	Long press (for 2 sec. or more)
Indicator on instrument cluster		-	SPORT	ECO	ECO+
Menu & Backlight color on instrument cluster		COMFORT / Blue	SPORT / Red	ECO / Green	ECO+ / Green
Heater and A/C control		COMFORT	COMFORT	ECO	Turned off (except defogger)
Speed limit		-	-	-	90 km/h or lower
Regenerative braking	Default settings	Level 1*	Level 1*	Level 2*	Level 2*
	Available levels	Level 1 to Level 3**	←	←	←
Default when IGN OFF → ON		COMFORT	SPORT	ECO	ECO+
Steering force		COMFORT	SPORT	COMFORT	COMFORT

4

ECO+ mode

- When ECO+ is selected for the drive mode, all heater and A/C systems, other than defroster, are turned OFF or operated in AUTO mode.
- You can use heater and A/C, if desired. But doing so may make it difficult to drive in extreme power saving mode.
- The speed limit triggered by this mode will be disengaged whenever the cruise control system is engaged or the accelerator pedal is fully depressed.
- The cruise control or IACC is disabled in ECO+ mode.

*: Default setting when entering the drive mode

** : Select the item Regenerative braking level under User Settings menu of the instrument cluster to set the desired level.

VCU remains in previous setup drive mode at restart before entering Sleep mode.

Intelligent / Adaptive Cruise Control*

Intelligent cruise control switch

Cruise control switch

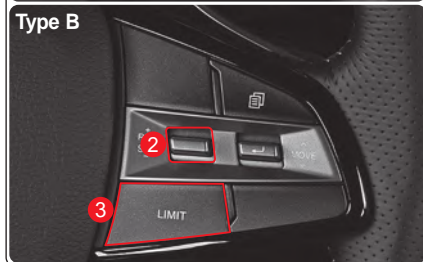
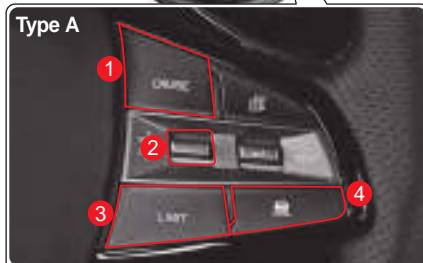

- 1 Intelligent cruise control ON/OFF switch
- 2 Speed selector lever
RES+
 - Reactivating cruise control
 - Increasing speedRES-
 - Set driving speed on cruise control
 - Decreasing speed
- 3 Safe distance setup button
- 4 Speed limit ON/OFF switch

Intelligent cruise control system

This system keeps the vehicle speed constant even if the driver does not depress the accelerator pedal and brake pedal. When a preceding vehicle is detected, it keeps the distance to the preceding vehicle constant at the preset distance. It allows the vehicle to travel in the middle of the lane via steering wheel (steering force) control.

Adaptive cruise control system

This is a convenient device to keep the vehicle speed constant even if the driver does not depress the accelerator pedal and brake pedal. When a preceding vehicle is detected, it keeps the distance to the preceding vehicle constant at the preset distance.

Intelligent Cruise Control Ready / Enabled Display

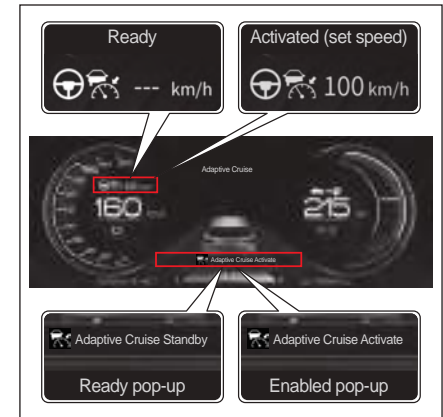

Set intelligent cruise (enabled)

When the intelligent cruise control is in the Ready mode and the speed control lever is lowered, the following message is displayed on the instrument panel LCD screen and the intelligent cruise control is enabled.

- “Intelligent cruise set” pop-up displayed
- Symbol and set speed displayed

The adaptive cruise control works when driving at a vehicle speed of about 10km/h or higher.

Notice

- The description in this section is based on the intelligent cruise control. Steering wheel (steering force) control does not work when the adaptive cruise control system is operating.

Intelligent Cruise Control Ready

The following message is displayed on the instrument panel LCD screen and the system enters intelligent auto cruise READY mode when you press the cruise control ON/OFF switch.

- “Intelligent cruise READY” pop-up displayed
- Symbol and “--- km/h” indicating that system ready to display speed displayed

Notice

- In standby mode, pushing up the speed adjustment lever in the RES+ direction reactivates the intelligent cruise control (IACC).

To enable intelligent cruise control at instrument cluster

- Go to **Driving Assist Setting** → **Intelligent Adaptive Cruise Control** under  (User Settings) in the instrument cluster and tick the box.

To set intelligent cruise control (IACC)

- 1 Press the cruise control ON/OFF switch. The intelligent cruise control (IACC) is activated.
- 2 “Intelligent cruise control set” message is displayed on the instrument cluster.
 - Then, the vehicle maintains the set speed without depressing the accelerator pedal and keeps driving in the middle of the lane via steering wheel (steering force) control.
 - If a preceding vehicle is detected, the driver’s vehicle will travel while maintaining a set distance to the vehicle ahead.
- 3 When the intelligent cruise control (IACC) is activated, the vehicle speed is set as follows:
 - Set to 30 km/h if vehicle speed less than 30 km/h
 - Set to current speed if vehicle speed 30 km/h or higher

- 4 You can change the set speed by lowering the speed control lever towards SET- or raising it towards RES+.

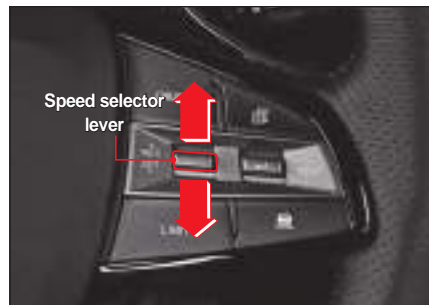

Caution

- The vehicle speed may decrease or increase temporarily on uphill or downhill while the intelligent cruise control is operating.

Increasing speed

To increase the set speed during intelligent cruise control operation, push the speed selector lever up toward RES+ without depressing the accelerator pedal.

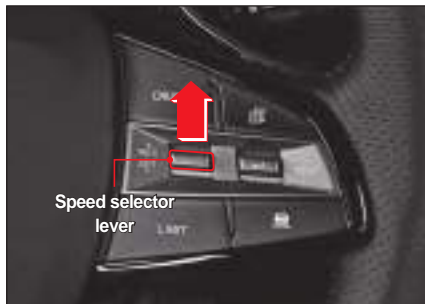

- Each time you push up the speed selector lever briefly, the speed increases by 5 km/h.
- If you push up the speed control lever for a long time, the speed increases by 10km/h. The vehicle setting speed increases continuously while the lever is being raised. (The set speed increases by a factor of 10.)
- You can set up to 155 km/h.

Caution

- **Since if you push up and hold the lever the vehicle speed increases quickly, be careful of the surrounding situation when operating.**

Decreasing speed

To decrease the set speed during intelligent cruise control operation, push the speed selector lever down toward SET- without depressing the accelerator pedal.

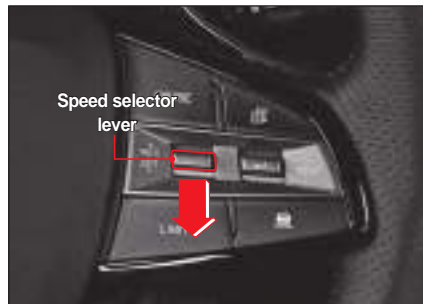

- Each time you push down the speed selector lever briefly, the speed decreases by 5 km/h.
- If you push down and hold the speed selector lever, the speed decreases by 10 km/h. The set speed decreases continuously while the lever is being lowered. (The set speed decreases by a factor of 10.)
- The lowest settable speed is 30 km/h.

Temporary acceleration (override)

Depress the accelerator pedal to accelerate the vehicle temporarily while intelligent cruise control is in operation.

Temporary acceleration is possible by driver's will without affecting the set speed.

In order to return the set speed, release the accelerator pedal. The vehicle will travel at the set speed.

Caution

- **If you depress the accelerator pedal for more than about 60 seconds for temporary acceleration, the intelligent cruise control system will stop operating.**

Deactivating

If any of the following conditions is met while intelligent cruise control is operating, it will be disabled. (intelligent cruise control ready mode)

Disable conditions

- Brake pedal depressed for braking
- Depressing accelerator pedal for more than 60 sec (override)
- Electric vehicle posture stability control system in operation (e.g., ESC, TCS and ABS)
- Electric vehicle posture stability control system OFF (by ESC OFF switch)
- SBW (shift by wire) in positions other than D (drive)
- EPB applied
- Driver's door open
- Maximum intelligent cruise control speed (165 kph) exceeded
- 3rd warning, emergency braking applied by AEBS
- HDC system in operation
- Heavily contaminated radar sensor cover
- Turning ECO+ on while driving

Other disable conditions

- No preceding vehicle at the time of restart after vehicle stop by control
- Distance to front vehicle too far or too close during vehicle stop control
- Vehicle stop control occurs frequently

Notice

- If "Intelligent cruise control READY" message is displayed on the instrument cluster with the disable conditions met, when you push up the speed selector lever toward RES+ briefly, the intelligent cruise control is reactivated.

If the intelligent cruise control is disabled, check the road situations and driving conditions. In addition, depress the brake pedal to adjust the vehicle speed properly.



Notice

- The message is displayed if the intelligent cruise control is disabled abnormally.

Resume

If the intelligent cruise control is disabled (intelligent cruise control ready), you may reactivate it.

Push up the speed control lever toward RES+ briefly at a vehicle speed of about 10km/h or higher without depressing the brake pedal or accelerator pedal.

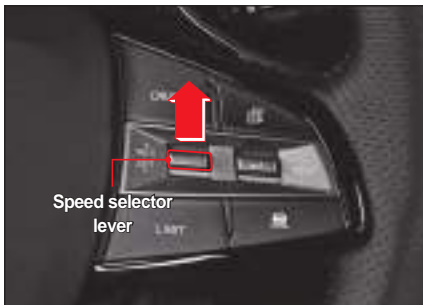

- The set speed returns to the value before intelligent cruise control was disabled.



Caution

- **When resuming, the vehicle speed can be increased or decreased quickly to the set speed just before it is disabled. Be aware of the surrounding road conditions before resuming.**

If the following message is displayed on the instrument cluster while the vehicle is stationary, push up or lower the speed selector lever briefly toward RES+ or SET-.

Then, the intelligent cruise control resumes.

Depressing the accelerator pedal also resumes the intelligent cruise control.



To Deactivate

In order to completely deactivate the intelligent cruise control (IACC), press the cruise control ON/OFF switch.

- Intelligent cruise pop-up disappears on the instrument cluster.

When not using the intelligent cruise control, always press the switch to deactivate it.



Caution

- **If you depress the accelerator pedal for more than about 60 seconds for temporary acceleration, the intelligent cruise control system will stop operating.**



Warning

- When not using the intelligent cruise control, always turn off the system.
- Always set the speed of the intelligent cruise control within the speed range specified by law.
- Check the surrounding road conditions prior to using the intelligent cruise control.
- Do not use the intelligent cruise control under following circumstances:
 - Near high interchange and tollgate
 - Where there are a lot of metals around road such as construction site and iron tunnel
 - Where lanes and guard rails in close proximity
 - Where there is no lane such as parking lot
 - Uphill or downhill with steep incline
 - Poor visibility due to factors such as fog, heavy rain, heavy snow, etc.
- The intelligent cruise control is a convenience feature for the driver. Do not use it as a safety device.
- The vehicle control should be determined by the driver at his/her own discretion. Relying on intelligent cruise control only increases the risk of accidents.

Steering wheel (steering force) control alert

If the driver does not hold the steering wheel while driving during intelligent cruise control's steering wheel control, the hands-off warning will be displayed to the driver in 3 steps and the intelligent cruise control system stops operating.

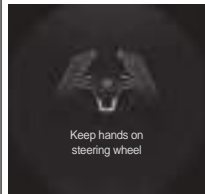
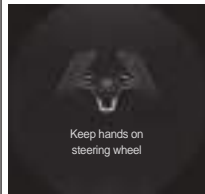
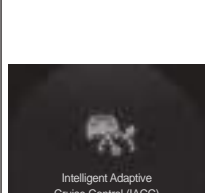
Pop-up	Description
	Step 1: Message <ul style="list-style-type: none"> • Warning message is displayed.
	Step 2: Message + Beep <ul style="list-style-type: none"> • Warning message is displayed and beep sounds.
	Step 3: Message + System disabled <ul style="list-style-type: none"> • "Intelligent cruise control disabled" message is displayed and steering control is disabled at the same time. However, the cruise control still functions.



Caution

- If the driver hold the steering wheel so weakly that there is no left or right movement when driving on a straight road, the system may determine that the driver does not hold the steering wheel and may generate a hands-off warning.
- Hands-off warning may be issued late depending on the road conditions. Always hold the steering wheel while driving.



Caution

The steering wheel (steering force) control system may not function or intervene unnecessarily under following circumstances:

- The system cannot recognize the lane markings because of rain, snow, dust, standing water or puddles, other obstruction on the road.
- The color of the lane markings is not clearly distinct from the road color.
- The lane markings are not clear or tampered by the traffic, or there are 2 or more lane markings on one side.
- There are other markings similar to the lane markings on the roads.

- The lane markings are covered in shadows of the median barriers, guardrails, noise barrier walls, roadside trees.
- There are environmental barriers, such as bollard.
- The traffic is heavy due to the construction in the area or traffic control items, such as traffic cones, are used to separate traffic flows.
- The lane markings are suddenly discontinued at roundabouts and road intersections.
- The vehicle is passing through a certain section, such as highway interchange, where the number of lanes increases or decreases.
- The width of the driving lane is too narrow or wide.
- The distance to the vehicle ahead is too short or a wheel of the vehicle ahead is touching the lane marker.
- There are other roadway markings on the roads, such as crosswalk markings, arrows, symbols, along with the lane markings.
- Poor visibility due to factors such as fog, heavy rain, heavy snow, etc.
- Hard to recognize other vehicles and pedestrians because of poor visibility.
- There is rapid change of illumination, for example at tunnel entry and exit points.

- The headlamps are not turned on or the brightness of the lamps is too low when driving at night or through tunnels.
- When you are traveling within or near the outer edges of the bus-only lane.
- The vehicle is driven on a steep hill or around sharp corners.
- the vehicle is driven under specific conditions which cause severe vibration.
- Objects with reflective surface (white paper, mirror, etc.) are on the dashboard.
- The windshield glass in front of the camera module is covered with ice, snow, slush, mud, dirt or debris.
- Fog or mist on the windshield.
- The temperature around the front view camera is too high because of the direct sunlight.
- The vehicle is moving towards a light source.
- The light from the sun, streetlamps, or headlamps of oncoming vehicles is reflected by the wet road surface.
- Bend such as sharp S-curve

To set safety distance to front vehicle

If the preceding vehicle is detected while the intelligent cruise control is operating, this system allows the driver's vehicle to maintain a distance to the preceding vehicle constant.

If the intelligent cruise control is activated, it will operate with the previously set safety distance without separate operation. If necessary, press the safety distance set button to change the inter-vehicle distance (safety distance) in 5 steps.

Set the safety distance according to the current vehicle speed.



- The set speed returns to the value before intelligent cruise control (IACC) was disabled.



- If no preceding vehicle is detected, the vehicle travels at a speed set to the intelligent cruise control system.
- When the preceding vehicle accelerates and the inter-vehicle distance increases, the driver's vehicle accelerates only up to the set speed and then travels at constant speed.

Forward situation awareness



If the distance to the front vehicle is so close that a collision can occur or the front vehicle disappears from the front view due to lane change, etc. while the intelligent cruise control is activated, the message is displayed on the instrument cluster.

- If the driver has to operate the brake pedal or steering wheel, immediately reduce the vehicle speed or change the direction.

Caution

- If the front vehicle disappears from the front view due to lane change, etc. while traveling and maintaining the distance to the front vehicle constant at a low speed the driver's vehicle may collide with a newly appearing stationary vehicle or object.

Starting at congested areas



When the intelligent cruise control is operating, in congested areas, drive the vehicle while maintaining the distance to the front vehicle constant. Depress the accelerator pedal or push up the speed selector lever toward RES+ briefly or lower it toward SET- briefly to restart the vehicle 3 seconds after since the vehicle stops due to the front stationary vehicle.

Front detection sensor (Front radar + front camera)

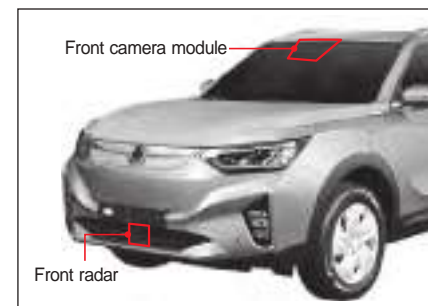



Front radar

It is a sensor that detects the front vehicle and allows the driver's vehicle to maintain the distance to the front vehicle constant and follow the front vehicle. If snow, rain, or foreign objects are stuck around the front sensor, the sensing performance of the sensor may deteriorate and intelligent cruise control may not function or may be temporarily disabled. Always keep the area around the front radar sensor clean.

Front camera

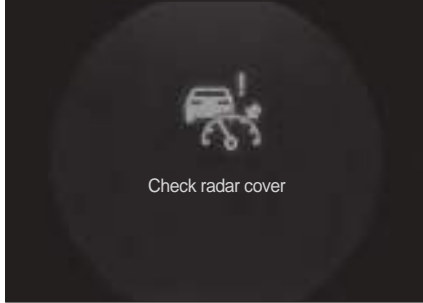
The camera detects the lane ahead of the vehicle through the sensor of the front camera module (FCM), allowing the vehicle to maintain the middle of the lane during intelligent cruise control operation. Always keep the area around the front camera module clean.



 **Caution**

- Always keep the area around the front detection sensor clean and never attach any accessory (license plate molding, sticker etc.).
- Be careful not to damage the sensor due to high-pressure washing or to prevent water from entering during car washing (lower part).
- After car washing, be sure to wipe off moisture around the sensor.
- Avoid subjecting the front bumper to impacts. The impact may change the sensing area of the sensor.
- Use a genuine sensor only.
- Do not paint the front bumper arbitrarily.

Vehicle detection is difficult under the following circumstances:

- Driving on a steep hill or sharp corners
- Driving under specific conditions which cause severe vehicle vibration
- A vehicle or a pedestrian recklessly cuts in front of you
- There is an approaching or reversing vehicle
- there is a vehicle with arbitrary shape
- Vehicle traveling close to one side lane or ahead
- Vehicle traveling at a very low speed or performing abrupt deceleration
- Stationary vehicle
- Vehicle with narrow rear structure (trailer, motorcycle, bicycle, etc.)
- When driving on a narrow road or a road with heavy curve
- When operating steering wheel
- When front part of vehicle lifted upwards due to excessive load in luggage compartment
- Foreign object stuck in sensor due to snow, rain, fog, etc.
- Vehicle which moves or is parked perpendicular to the direction of travel for your vehicle

 **Caution**

- The system may not recognize the preceding vehicle under the circumstances described earlier. Special care is required. Always be careful of motor traffic and reduce the vehicle speed by depressing the brake pedal, if needed.

Not detected preceding pedestrian

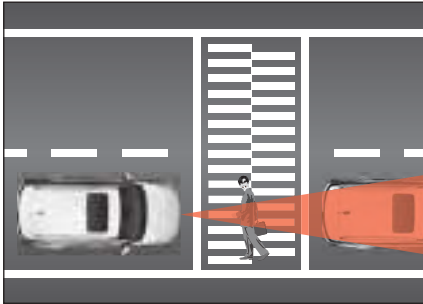

- The intelligent cruise control may not detect people.
- When traveling while maintaining the inter-vehicle distance, if a pedestrian appears in front of your vehicle, which can cause a dangerous situation.

Curved road



- The system may fail to recognize a preceding vehicle in the same lane on a curved road and accelerate the vehicle to the set speed rapidly.
- If the preceding vehicle is suddenly detected, the vehicle speed may decelerate rapidly.
- Always be careful of motor traffic and reduce the vehicle speed by depressing the brake pedal, if needed.



- It may detect a vehicle in a different lane on a curve and which may affect the driver's vehicle speed. Always be careful of motor traffic and reduce the vehicle speed by depressing the brake pedal.
- In this case, check the traffic conditions around you, then step on the accelerator pedal to prevent unnecessary deceleration.

Uphill or downhill



- The vehicle may accelerate to the driver set speed rapidly by failing to recognize a preceding vehicle in the same lane on an uphill or downhill.
- If the preceding vehicle is suddenly detected, the vehicle speed may decelerate rapidly.
- Always be careful of motor traffic on the uphill or downhill and reduce the vehicle speed by depressing the brake pedal, if needed.



Warning

- **Never charge the battery over 90% SOC in high altitudes such as mountainous areas.**
- **When driving downhill after fully charging the battery, braking may be delayed due to the inability of regenerative braking.**

To change lane

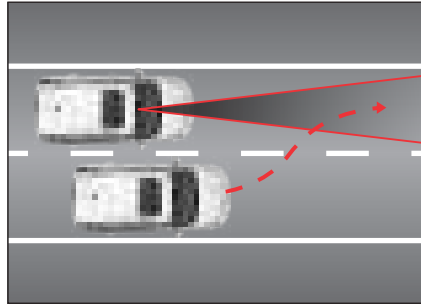

- When a vehicle in the lane next to you enters the same lane, the system may fail to recognize this vehicle until it enters into the sensor detection area.
- Be cautious at all times since the sensor may detect a vehicle cutting in suddenly late.
- Make sure to decelerate to maintain the vehicle-to-vehicle distance when an interposing vehicle's speed is lower than the driving speed.
- Make sure to keep the set speed to maintain the distance to a preceding vehicle when an interposing vehicle's speed is faster than the driving speed.

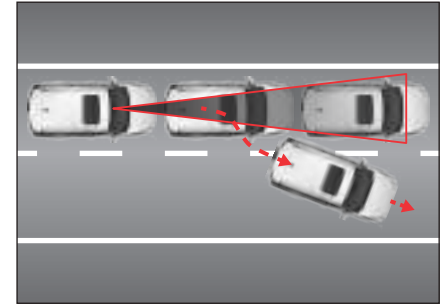

- If the front vehicle leaves the lane due to lane change, etc., be careful that there is a risk of collision because the system can not detect another vehicle ahead.

Detecting vehicle ahead

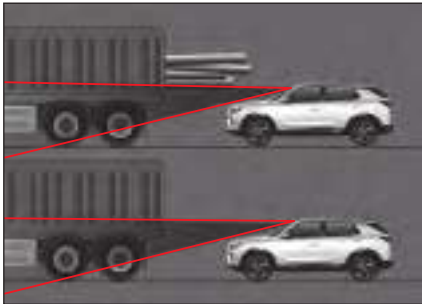

- Your attention is always required while driving behind a vehicle carrying cargo longer than the cargo bed or with high ground clearance because the AEBS may not work properly.

Warning

- In the event of an emergency, always stop the vehicle by depressing the brake pedal.
- Keep safety distance at all times. In particular, if you set the distance to the preceding vehicle to closer at high speed, it can cause a very dangerous situation such as collision with the front vehicle.
- The intelligent cruise control system can not cope with the vehicles parked in front, vehicle stopping suddenly, pedestrians, vehicles coming on opposite sides, etc. The driver should always be careful to look ahead and respond to unforeseen circumstances.
- If the preceding vehicle changes lanes frequently, the sensor recognition response rate may be slower. The driver should always be careful to look ahead and respond to unforeseen circumstances.
- The intelligent cruise control is a convenience device for the driver and not a safety device. The safe maneuvering and controls are always the driver's responsibility.

Warning

- The driver should always be aware of the intelligent cruise control set speed and distance to the front vehicle.
- Always allow for extra distance between your vehicle and the vehicle ahead. Reduce the vehicle speed by depressing the brake pedal, if needed.
- The intelligent cruise control can not recognize complicated traffic conditions, so you should always be careful about traffic conditions while it is operation and the driver must adjust the vehicle speed personally in dangerous situations.
- To use the intelligent cruise control more safely, be sure to read and familiarize yourself with the user manual before using it.

Caution

- The intelligent cruise control may be deactivated in an instant by strong electromagnetic waves.

Safety Speed Assist (SSA)

The safety speed assist (SSA) is a system for your convenience. This system receives the speed limit information from the navigation system to reduce the vehicle speed accordingly in advance while driving on the highway. Therefore, driving the vehicle at a speed greater than the speed limit set for a speed enforcement camera is prevented.

Notice

- The SSA works only when traveling on a highway.

SSA status indicator

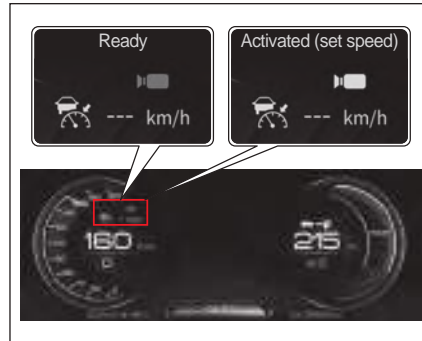

Enabling SSA

If operating conditions for SSA system are met, provided that the item Safety Speed Assist under User Settings menu of the instrument cluster is selected, the system is activated.



- How to enable
Go to  (User Settings) → Driving assistance settings → Forward safety assist and select the item Safety Speed Assist.

SSA operating conditions

For the SSA system to be activated, the following conditions must be met, provided that the item Safety Speed Assist is select in the User Settings menu:

- Navigation system is running.
- Speed enforcement camera alert is set to ON in the navigation system settings.
- Adaptive cruise control (ACC) / intelligent cruise control (IACC) system is operating (acceleration / deceleration control enabled).

SSA operation

- The SSA receives the information of the speed enforcement camera ahead from the navigation system to reduce the vehicle speed accordingly.
- If a speed enforcement camera is detected up ahead (about 1 km or more from your vehicle), the instrument cluster displays  (ready).
- If the speed enforcement camera is located about 1 km ahead of the vehicle, the instrument cluster displays  (activated).
- Once the “activated” icon is displayed, the vehicle speed will be adjusted to the set speed of the speed enforcement camera.
- After you passed the point where the speed enforcement camera is located, the SSA will remain activated for some time until the  (activated) on the instrument cluster is turned off.



Caution

- **The SSA controls the vehicle speed only for the speed enforcement cameras on a highway set in the navigation system.**
- **The driver should always drive the vehicle within the regulated speed specified by law.**



Caution

- **The driver has the right of priority for all operations related to vehicle operation.**
- **The SSA system is activated only when the driver sets the function through User Settings menu from the instrument cluster.**
- **It works only for the speed enforcement cameras on a highway.**
- **Depending on the navigation settings, some speed enforcement cameras are not informed.**
- **The SSA may not function while driving the vehicle and maintaining the distance to the vehicle in front by using the ACC.**
- **The navigation alert may differ from the actual start / end points of a speed enforcement camera.**



Caution

- **In a speed limit zone, the vehicle speed is adjusted depending on the target average driving speed for the remaining range.**
- **The vehicle does not accelerate beyond the speed limit unless the driver steps on the accelerator pedal on his/her own will.**
- **When passing a mobile speed enforcement camera, the system may maintain the adjusted driving speed for some time even after passing by the camera location, for safety reasons.**
- **It does not work for the speed enforcement cameras located on urban expressways / national roads / public roads.**
- **The driver should pay attention to the speed limit on the roads other than highways and drive safely for his/her own safety.**
- **The speed displayed on the instrument cluster and the speed displayed on the navigation system may vary.**

Warning

- Regardless of whether the SSA is activated or not, the driver always has to keep his/her eyes on the road and drive safely, and is responsible for doing his/her best not to violate the Road Traffic Act.
- The SSA relies entirely on the information provided by the navigation system. The manufacturer has no liability for the driver's violation of road traffic laws or accidents caused by driver's carelessness.
- If the navigation system does not work properly, the SSA may not work.
- The SSA may malfunction or not work at all when:
 - the navigation data is not up-to-date or there is a newly installed speed enforcement camera.
 - an error occurs in real time GPS data or map data.
 - the navigation system is carrying out route search, video playback, voice command, hands-free function, etc.
 - the navigation is searching for an alternative route while driving.

Warning

- the GPS signal is not received or weak because of tunnel or radio interference.
 - the driver moves out of the route that was searched for by the navigation.
 - the driver resets a destination and the navigation system is searching for a route again.
the guided route differs from traveling route (e.g., highway rest stop).
 - the speed limit of some sections is temporarily changed due to the highway conditions.
 - a smart phone mirror link feature, such as Android Auto or CarPlay, is enabled.
 - Upper and lower roads or adjacent roads are located side by side
- If the driver accelerates by stepping on the accelerator pedal during the SSA operation, the deceleration may not be sufficient to guarantee driver's safety.
 - If the driver accelerates with his/her own will while the SSA is in operation, the vehicle may suddenly decelerate if the driver releases the accelerator pedal.
 - The SSA may not slow down the vehicle sufficiently. Depress the brake pedal appropriately to reduce the vehicle speed, if necessary.

Warning

In the following situations, the SSA may operate differently from the driver's intention. The driver should always pay attention to the situations ahead of the vehicle and respond to unforeseen circumstances.

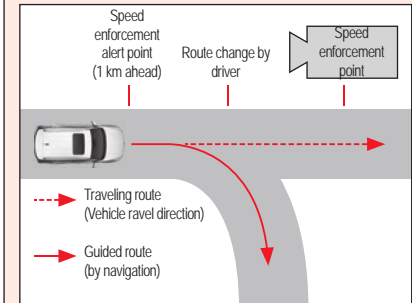

- **Scenario 1:**
Navigation-guided route differs from actual traveling route

Since there is no speed limit information in the navigation-guided route, SSA does not function. However, if the vehicle is traveling on a road (speed limit zone) other than the set route on the driver's will, the SSA may decelerate the vehicle automatically decelerated without preparatory stage.

In this case, it is possible to make a rapid braking according to the distance to the over speed enforcement camera point and the current vehicle speed.

Warning

Speed enforcement alert point (1 km ahead) Route change by driver Speed enforcement point

Traveling route (Vehicle travel direction)

Guided route (by navigation)

- **Scenario 1:**
Navigation-guided route differs from actual traveling route

The SSA works according to the speed limit information on the navigation-guided route. However, if the vehicle is traveling on a road (zone without speed limit) other than the set route on the driver's will, the SSA does not work when it determines that the vehicle is moving out of the route.

At this time, the vehicle deceleration may occur momentarily if the SSA is operating or ready state.

Warning

Speed enforcement alert point (1 km ahead) Route change by driver Speed enforcement point

Traveling route (Vehicle travel direction)

- **Scenario 1:**
Traveling in safe driving mode with no route setting (guidance)

If you are traveling in safe driving mode without setting the route in the navigation, SSA works according to the speed limit information detected up ahead.

However, when driving on a road with no speed limit information, the SSA stops working.

At this time, the vehicle deceleration may occur momentarily if the SSA is operating or ready state.

Speed Limit Warning (TSW)

The Speed Limit Warning (TSW) system is a safety device that prevents the vehicle from accelerating beyond the set speed even if the driver depresses the accelerator pedal on his/her own will.

Images that show readiness and operation

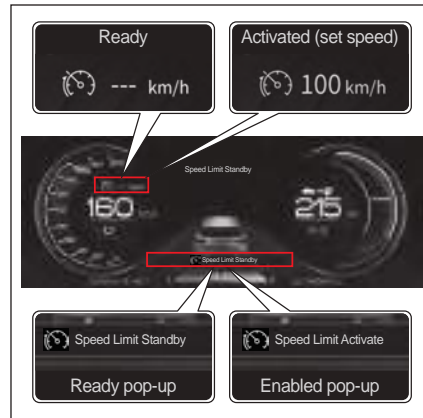

Speed Limit Warning (TSW) ready

The following message is displayed on the instrument panel LCD screen and the system enters Speed Limit Warning (TSW) READY state when you press the Speed Limit Warning (TSW) ON/OFF switch.

- "Speed Limit Warning (TSW) READY" pop-up displayed
- Symbol and "--- km/h" indicating that system ready to display speed displayed

To set Speed Limit Warning (TSW)

When the Speed Limit Warning (TSW) is in Ready state and the speed selector lever is lowered, the following message is displayed on the instrument panel LCD screen and the Speed Limit Warning (TSW) is set (activated).

- "Speed Limit Warning (TSW) set" pop-up displayed
- Symbol and set speed displayed

How to enable Speed Limit Warning (TSW) in instrument cluster

- Go to **Driving Assist Setting** → **Speed Limit Warning (TSW)** under  (User Settings) in the instrument cluster and tick the box.

To set speed

- When you raise or lower and hold the speed selector lever with the Speed Limit Warning (TSW) set (activated), the set speed is changed by 5 km/h.
- When you raise or lower the speed selector lever briefly with the Speed Limit Warning (TSW) set (activated), the set speed is changed by 1km/h.

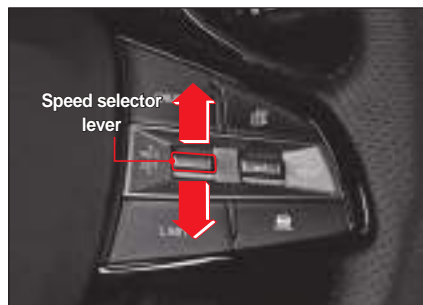

Notice

- If the tires of your vehicle are replaced with tires with different size at your disposal, it may cause an error in the set speed. In this case, please contact our service center.

To deactivate speed limit warning (TSW)

- Operate speed limit warning (TSW) ON/OFF switch twice
- Operate cruise control ON/OFF switch once

Brake system

Warning lights/Indicators for brake system



Brake warning light



ABS warning light



Regenerative braking warning light



EBD warning light (illuminating simultaneously)



BBS warning light (illuminating simultaneously)



EPB warning light



AUTO HOLD indicator/warning light



HDC ON indicator/warning light



ESC ON indicator/warning light



ESC OFF indicator

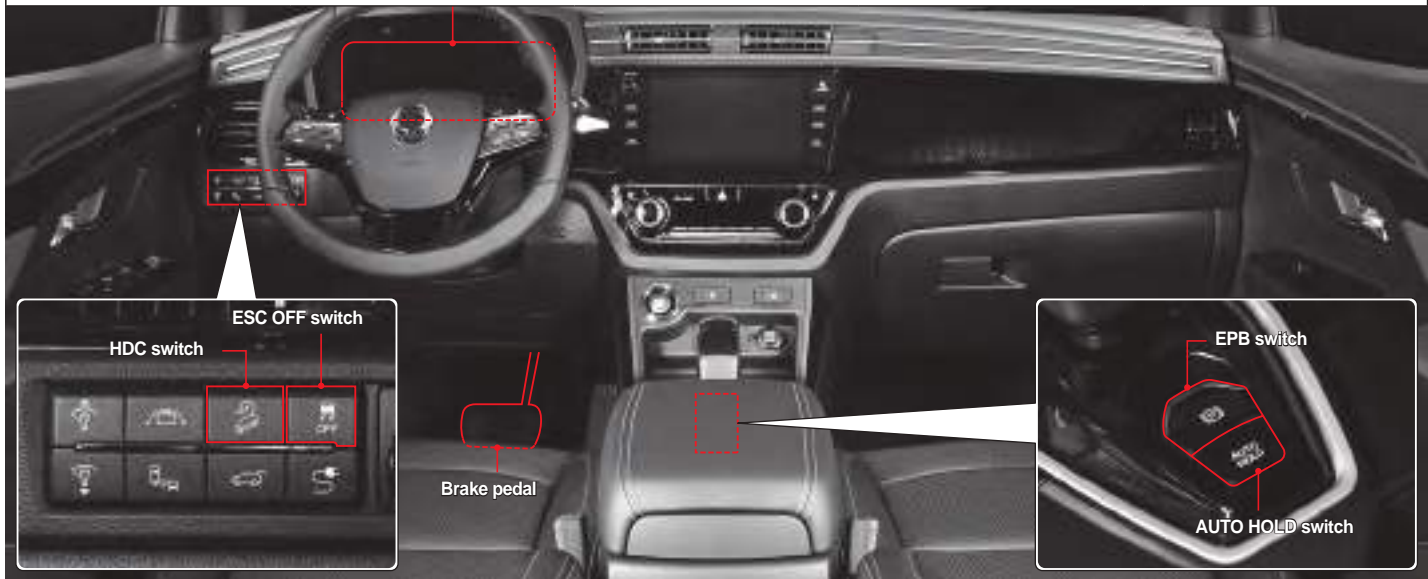

Foot brake

Depressing the brake pedal can reduce the vehicle speed or stop the vehicle.

If the foot brake is used for a long period of time on a long downhill road, the fade or vapor lock phenomenon may occur due to the overheating of the brake system, reducing the braking performance and causing an accident.

Do not only apply the foot brake on long downhills, but also use regenerative braking (increase regenerative braking with paddle shift lever).



Caution

- Reduce the speed properly using the engine brake on a slippery road such as an icy road or a snowy road.

What is the fade phenomenon?

The fade phenomenon is the reduction of braking force due to a decrease in the friction force caused by a temperature increase in the friction surface of a brake when the brake is applied excessively on a long downhill road.

What is the vapor lock phenomenon?

The vapor lock phenomenon is the condition that when the brake is applied excessively on a downhill road, bubbles form in the brake fluid in the wheel cylinder or brake pipe of the hydraulic brake so that proper hydraulic pressure cannot be transferred, causing the brake system not to operate properly even if the pedal is depressed.



Warning

Checking for foreign materials on the pedal operation area



- Before driving the vehicle, clean up the area where the brake pedal or the accelerator pedal is operated. If an empty can or an article is present below the pedal, it may obstruct the pedal operation, causing an accident. Be sure to check before driving the vehicle.

Checking and replacing the brake pads/discs

Check the brake pads and discs at every 10,000 km of driving and replace if necessary. When replacing the brake pad, replace the left and right brake pads at the same time.

The replacement period of the brake pads and discs may vary depending on the driver's driving habit.



Warning

- **If you hear a screeching sound when you depress the brake pedal, have your vehicle checked and serviced at a nearby KG Mobility Authorized Service Center. Failure to do so may cause the brake not to operate, causing a serious accident.**

If the brake is not working

If the foot brake does not work while driving, use regenerative braking (increase regenerative braking with paddle shift lever) to decelerate as much as possible, then apply the parking brake to safely stop the vehicle.

ABS (Anti-Lock Brake System)

If you apply sudden braking or apply braking on a slippery road, the vehicle continues to move forward but the wheels are locked, not rotating. In such case, steering may not be possible or the vehicle may spin, causing an accident.

In such case, the ABS controls the locking of the wheels properly to maintain the steering force and improve the steering stability of the vehicle.

In normal driving conditions, the braking system of a vehicle equipped with the ABS operates in the same way as the braking system of a normal vehicle.



Warning

- **The ABS system prevents a situation that the wheels are locked, disabling the steering of the vehicle, when the braking is applied. Therefore, the ABS system does not affect the braking distance significantly.**
- **When the ABS system operates and the braking force is created, the braking distance may become longer or shorter than the braking distance of a vehicle without the ABS system according to the road surface condition.**
- **When applying a sudden braking, depress the brake pedal strongly until the vehicle stops completely. Never take your foot off from the pedal or depress the pedal in a pumping manner.**
- **Even a vehicle equipped with the ABS system cannot prevent a risk of the vehicle skidding sideways. Be sure to keep a proper safe distance from a preceding vehicle and drive the vehicle at a low speed on a slippery road.**

 Caution

- A vehicle equipped with the ABS system performs the self-diagnosis function to check whether the system is abnormal or not after the vehicle is started and the vehicle is driven. In this process, the hydraulic pressure is transferred to the internal hydraulic system forcibly and the motor operates accordingly, so noises and vibrations may occur on the brake pedal. This indicates that the ABS is functioning normally.
- When the ABS system operates, you may feel vibrations through the brake pedal along with some noise. This is a normal phenomenon that occurs when the ABS system operates.

ABS warning light



This warning light turns on when the START/STOP switch is in the ON status and it turns off if the system is normal.

 Warning

- If the ABS warning light stays on after the vehicle is started or it turns on while driving, this indicates that an ABS-related system is abnormal, and the ABS system does not operate and only normal braking function is activated. In such case, have your vehicle checked and serviced at a KG Mobility Authorized Service Center promptly.

Electronic Brake-Force Distribution (EBD)

The EBD system distributes the braking force to the front wheels and the rear wheels efficiently by controlling the braking pressure electronically when the brake pedal is depressed.

The EBD system is activated when the speed difference between the fastest front wheel and the slowest rear wheel is approximately 1 km/h or more, and it is deactivated when the ABS operates.

EBD warning light



When the ABS warning light and the brake warning light turn on at the same time, it indicates that the EBD system is abnormal. (There is no separate EBD warning light.)

 Caution

- When the EBD warning light turns on, have your vehicle checked and serviced at a KG Mobility Authorized Service Center.

Emergency Stop Signal (ESS)

The ESS function informs of a dangerous situation to a following vehicle by blinking the emergency braking light fast when a sudden braking is applied or the ABS system operates while driving.

The ESS function operates when the vehicle speed is 50 km/h or higher, and it operates in the sequence of "Input ESS signal" → "Operate emergency braking light" → "Operate the hazard warning lamp".

Notice

- If the hazard warning lamp is on, the ESS function is not activated.

Activation and deactivation conditions

	Emergency braking light
Activation conditions	<ul style="list-style-type: none">• When the vehicle speed is 50 km/h or higher• When a sudden braking with the vehicle deceleration of 6.5m/s² or higher is applied• When the ABS system is operating while applying braking
Deactivation conditions	<ul style="list-style-type: none">• If there is no ESS from the vehicle• When the hazard warning lamp is activated• When the ABS operation is finished

	Hazard warning lamp
Activation conditions	<ul style="list-style-type: none">• If the vehicle speed is 50km/h or less at the time when the operation of the hazard warning lamp indicator is finished (canceled)• If the hazard warning lamp blinks for 10 seconds
Deactivation conditions	<ul style="list-style-type: none">• When the hazard warning lamp is activated• When 10 seconds have passed after the hazard warning lamp is activated• When the vehicle speed has increased by 10 km/h or more after the hazard warning lamp is activated

Electronic stability control system (ESC)*

The ESC system is an auxiliary driving safety system that controls the braking of each wheel or the motor output in order to correct the vehicle stability when it becomes unstable such as rapid cornering, helping the vehicle to avoid a dangerous situation.

- The ESC function is activated only when the vehicle becomes extremely unstable and it is not activated in normal driving conditions. You can confirm its activation from the blinking of the ESC indicator on the instrument cluster.

ESC indicator/warning light



- Indicator blinks: When the ESC function is activated
- Warning light turns on: When the ESC system is abnormal



Caution

- If the ESC indicator blinks, drive slowly without accelerating.
- If the ESC warning light turns on, visit a KG Mobility Authorized Service Center and have your vehicle checked and serviced.

Notice

- The hazard warning lamp blinks for approximately 10 seconds to allow a vehicle right behind or around to prepare in advance when you apply sudden braking at the vehicle speed of 50 km/h or higher or the ABS system operates. (Emergency Stop Signal)

ESC OFF indicator



When you deactivate the ESC by pressing and holding down the ESC OFF switch (for 3 seconds or more), the indicator turns on.



Caution

- If the ESC OFF indicator stays on even though you did not deactivate the ESC function, visit a KG Mobility Authorized Service Center and have your vehicle checked and serviced.

Notice

- Pressing and holding down the ESC OFF switch for 3 seconds turns on the ESC OFF indicator and the AEBS OFF indicator at the same time, and the ESC function and the AEBS function are deactivated.

Phenomenon that occurs when the ESC is activated

If the ESC is activated due to tight cornering, the ESC controls each wheel, so you can feel that the braking is applied to the relevant wheel, and vibrations on the brake pedal and noises may occur due to a change in the hydraulic pressure inside the system.

Also, there may be cases where the vehicle speed does not increase even when the accelerator pedal is depressed by the motor output control function.

When it is necessary to deactivate the ESC function

If the left and right driving wheels are slipping on a snowy road or an icy road continuously, the ESC function is activated to control the motor driving force. Accordingly, the motor driving force cannot be increased even if you depress the accelerator pedal, disabling you to drive the vehicle.

In such case, deactivate the ESC function to restore the motor driving force so that you can drive the vehicle.

- To deactivate the ESC function, press and hold down the ESC OFF switch (for 3 seconds or more).

The ESC OFF indicator on the instrument cluster turns on and the ESC function is deactivated.

- Pressing the ESC OFF switch again activates the ESC function.



Warning

- While the ESC is operating, do not press the ESC OFF switch. If you deactivate the ESC function by pressing the ESC OFF switch while suddenly accelerating or making a sharp turn, the vehicle may slip suddenly, causing a very dangerous situation. To deactivate the ESC function, be sure to press the ESC OFF switch only when you drive the vehicle on a straight flat road at a fixed speed.

Notice

A vehicle equipped with the ESC includes various auxiliary functions for improving the driving safety of the vehicle. The typical functions are as follows.

- BAS (Brake Assist System)

The BAS function detects a sudden braking situation and increase the brake pressure for a driver with leg strength who cannot apply sudden braking in a sudden braking situation.

- ARP (Active Roll-over Protection)

The ARP is an auxiliary safety function that helps the vehicle to maintain normal stability prior to the ESC when the driving status of the vehicle is highly unstable.

Caution

- The ESC is just a driving safety assist system of the vehicle and it cannot control the vehicle beyond its physical limitation. Do not rely too much on this system and be sure to drive safely.
- The activation of the ESC (the ESC indicator blinks) indicates that the vehicle is highly unstable. In such case, reduce the vehicle speed and drive the vehicle safely.
- The ESC is not activated when reversing the vehicle.

- Do not drive the vehicle immediately after starting the vehicle. When you drive the vehicle within 2 seconds after starting the vehicle, the self-diagnosis function of the ESC is not carried out and the ESC is activated in early stage while driving so that symptoms such as the ESC warning light turning on, warning buzzer and the generation of braking force on each wheel may occur.
- When the ARP function is activated, the braking of the motor and each wheel is controlled more powerfully in comparison to normal ESC operation, so the vehicle speed may decrease rapidly or strong braking force on each wheel is created, making the steering status unstable.
- When the ESC operates, vibrations and noises may occur on the brake pedal and other relevant devices due to a change in the hydraulic pressure inside the device.
- A vehicle equipped with the ESC may have slight vibrations while the self-diagnosis function is being carried out for the system, but this is a normal phenomenon.

Hill Descent Control (HDC)

HDC is the system that decelerates the vehicle automatically to allow the driver to drive the vehicle at a low speed without depressing the brake pedal when the driver intends to drive the vehicle on a steep road at a low speed.

The variable type HDC applied to this vehicle operates flexibly in the range between 5 km/h and 30 km/h according to the vehicle environments (operation status of brake and accelerator pedal).

Warning

- Do not use the HDC function on a normal road. The HDC function is for driving on a downhill road, and using it on a normal road may cause a collision with a following vehicle.

Activating/deactivating the HDC function

- Pressing the HDC switch turns on the green HDC indicator on the instrument cluster and the HDC is in ready status.
- Pressing the HDC switch again turns off the HDC indicator and deactivates the HDC function.



HDC indicator/warning light



- Green indicator turns on: HDC in ready status
- Green indicator blinks: The HDC is operating.
- Red warning light turns on: The HDC system is overheated and abnormal.

Caution

- **When the red warning light turns on, the HDC function is not activated.**
- **When the red HDC indicator turns on, it indicates that the HDC system is overheated or abnormal. If the red HDC indicator stays on after the HDC-related device has been cooled down properly, have your vehicle checked and serviced at a KG Mobility Authorized Service Center.**

HDC activation conditions

- When the HDC function is activated (green HDC indicator turns on)
- Within a certain degree of slope or higher and the operating speed range (approximately 2 km/h ~ 50 km/h)
- When the ESC function (including the BAS function) is not activated

HDC deactivation conditions

- When the HDC function is deactivated (green HDC indicator turns off)
- Degree of slope below the HDC activation condition
- When the vehicle speed is less than 2 km/h or more than 50 km/h
- When the HDC system is abnormal
- When the HDC system is overheated
- When depressing brake pedal or accelerator pedal with more than a certain force

Notice

- **While the HDC function is being activated, the driver can accelerate or decelerate the vehicle to the desired speed (approximately 5~30km/h) for driving by depressing the brake pedal or the accelerator pedal. However, if the vehicle speed is more than 70 km/h, the HDC function is deactivated.**

HDC operation

If the conditions for activating the HDC are met, the HDC is activated and the green HDC indicator on the instrument cluster blinks. If the vehicle speed becomes less than 2 km/h or more than 70 km/h or the sloping road becomes gentle while the HDC function is being activated, the HDC operation stops.

While the HDC function is operating, strong operating sounds and vibrations occur on the brake and this is normal according to the HDC operation.

Caution

- **The HDC function is for off-road driving on a steep downhill road.**
- **If the HDC function is used frequently, the brake system or the ESC may not operate normally.**
- **Avoid using the HDC function when driving on a normal road. If you drive the vehicle with the HDC ready status on a flat road, the HDC function may be activated when you make a tight cornering or pass through a speed bump.**
- **When the HDC is activated, vibrations and noises occur on the brake pedal and other relevant devices due to a change in the hydraulic pressure inside the device. This is a normal phenomenon according to the activation of the HDC.**

Electronic Parking Brake (EPB)

The EPB is the parking brake system with enhanced safety and stability that the parking brake is applied and released through a simple switch operation.



Warning

- Do not allow a person who is unfamiliar with the EPB (especially a child) to operate the EPB. Failure to do so may cause an accident according to the parking and stopping status.

Caution

- When the temperature falls down below zero during winter, the parking brake may not be released due to the freezing of EPB-related devices.
- Driving the vehicle forcibly with the parking brake not released due to the freezing of a EPB-related device may damage the relevant device. Noises may also occur when driving the vehicle.
- When you park the vehicle on a flat and safe place in a weather with below zero temperatures, use a chock on the wheels after parking instead of using the EPB.

Applying the EPB

- 1 Park the vehicle on a flat and safe place.
- 2 Pull the EPB switch.
The parking brake warning light on the instrument cluster turns on and the EPB is applied.



Releasing the EPB

With the brake pedal depressed, press the EPB switch.

The parking brake warning light on the instrument cluster turns off and the EPB is released.



Releasing the EPB automatically

When you fasten the seat belt with the driver seat door, hood and tailgate closed and drive the vehicle normally, the EPB function is released automatically.

Notice

- If the driver seat door, hood or tailgate is not closed or the seat belt is not fastened, the EPB auto release function is not activated.

EPB warning light/brake warning light

EPB warning light

EPB

- The EPB amber warning light turns on when the EPB system is abnormal.

Brake warning light



The warning light turns on in any of the following situations.

- When the parking brake is operating normally
- When the brake fluid is insufficient
- When the SBW (shift by wire) is moved to the P (parking) position with the AUTO HOLD activated

! Caution

- When applying or releasing the EPB, check if the parking brake warning light turns on or off on the instrument cluster.
- If the EPB switch is operated abnormally (excessive or continuous operation), the EPB warning light may turn on. At this time, when you turn off the vehicle and turn the START/STOP switch in the ON status, the warning light turns off and the EPB operates normally.
- If the EPB warning light stays on, have your vehicle checked and serviced at a KG Mobility Authorized Service Center.
- If the parking brake warning light stays on even though the parking brake has been released, have your vehicle checked and serviced at a KG Mobility Authorized Service Center immediately.

EPB emergency mode

When you pull the EPB switch up if the brake system malfunctions or you cannot depress the brake pedal while driving, the EPB is applied while the EPB is being pulled.

However, the braking distance may increase significantly in comparison to normal brake operation.

! Warning

- Never use the EPB emergency mode while driving unless it is an emergency. Doing so may damage the vehicle system and may make the driving status unstable due to the braking force while driving, resulting in an accident.
- If the brake system has a critical failure, the EPB emergency mode may not operate.

! Caution

- If you need to park the vehicle with a faulty EPB, place the SBW (shift by wire) in the P (parking) position and park the vehicle on flat ground.
- If a noise or a smell of burning occurs from the relevant devices after operating the emergency mode, have your vehicle checked and serviced at a KG Mobility Authorized Service Center.



Caution

- Before driving, be sure to check if the parking brake warning and the low oil warning light on the instrument cluster turn on.
- Be sure to release the parking brake before driving. Driving the vehicle with the parking brake applied may damage the brake system.
- When you use the parking brake for stopping while driving, move the SBW (shift by wire) to the P (parking) position or the N (neutral) position for safety.
- Do not use the P (parking) position of the SBW (shift by wire) instead of the parking brake. Be sure to apply the parking brake firmly when stopping or parking the vehicle.
- If you intend to place the SBW (shift by wire) in the N (neutral) and park the vehicle, turn off the vehicle with the SBW (shift by wire) in the P (parking) position, press the SBW (shift by wire) unlock button and move it to the N (neutral) position.
- Be sure to place the SBW (shift by wire) in the P (parking) position when parking or stopping the vehicle. If the SBW (shift by wire) is not in the P (parking) position when parking or stopping, the vehicle may move due to an impact from the outside or along the road surface.

When parking the vehicle on a uphill road

- When you park the vehicle on a uphill road, park the vehicle with the steering wheel turned in the opposite direction from the curb. After parking, make sure to install wheel chocks.

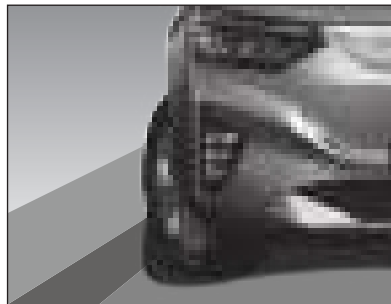

When parking the vehicle on a downhill road

- When you park the vehicle on a downhill road, park the vehicle with the steering wheel turned in the direction toward the curb. After parking, make sure to install wheel chocks.

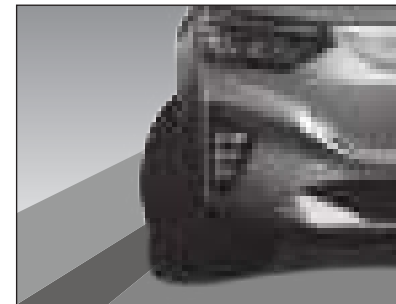

AUTO HOLD

When the “AUTO HOLD” function is activated, the vehicle keep the brake pressure in order to hold the vehicle stationary when you stop the vehicle by depressing the brake pedal in order to wait for a signal or in case of traffic congestion.

- In R (reverse) position, the AUTO HOLD function does not work.
- When you depress the accelerator pedal, the brake is released automatically, allowing you to drive the vehicle.



Activating the AUTO HOLD function

When you press the AUTO HOLD switch, the AUTO HOLD indicator (white) turns on and the AUTO HOLD function is activated.



Deactivating the AUTO HOLD function

- When you press the switch with the AUTO HOLD activated, the AUTO HOLD function is deactivated.



Using the AUTO HOLD function

- 1 Press the AUTO HOLD switch.
The AUTO HOLD indicator (white) on the instrument cluster turns on.
- 2 Stop the vehicle completely by depressing the brake pedal while driving.
The color of the AUTO HOLD indicator changes from white to green and the brake is applied.
- 3 Depress the accelerator pedal slowly when driving the vehicle.
The color of the AUTO HOLD indicator changes from green to white, and the brake is released.

4

Warning

- When you drive the vehicle on a downhill road, do not depress the accelerator pedal suddenly. Doing so may cause the vehicle to move fast, causing a dangerous situation.

AUTO HOLD indicator/warning light

AUTO HOLD

- White indicator turns on: AUTO HOLD function in ready status.
- Green indicator turns on: AUTO HOLD function is activated and maintain the brake pressure to keep the vehicle stationary.
- Yellow warning light turns on: When the AUTO HOLD system is abnormal.



Caution

- The Auto Hold does not operate when:
 - The driver's door is opened
 - The motor room hood is opened
 - The tailgate is opened
 - The EPB is applied
- The 'Auto Hold' automatically switches to EPB in such cases:
 - The driver's door is opened
 - The motor room hood is opened
 - The tailgate is opened
 - The vehicle is in a standstill for more than 10 minutes
 - The vehicle is standing on a steep slope



Caution

- The AUTO HOLD function is also activated when reversing. If it is necessary to deactivate it for reasons such as parking or stopping, deactivate the AUTO HOLD.
- Be sure to deactivate the AUTO HOLD function if wheel drive is necessary such as automatic car wash.
- During the break-in period of parking brake pads, the braking force of the parking brake may be slightly reduced. (If the vehicle is parked on a sloping road, the vehicle may roll down.)
- Check the brake pads for wear and the operation status of the Electronic Parking Brake (EPB) every 10,000 km.
- When the Electronic Parking Brake (EPB) is applied, a mechanical operating sound may occur. This is a normal operating sound of the Electronic Parking Brake (EPB) system.

- If the Electronic Parking Brake (EPB) warning light turns on, the Electronic Parking Brake (EPB) operation is abnormal, have your vehicle checked and serviced at a KG Mobility Authorized Service Center. If you need to park the vehicle in case of emergency, stop the vehicle on flat ground, place the gear shift lever in the P (parking) position and use a chock on the wheels.
- When you need to turn off the vehicle in AUTO HOLD operation ready (white indicator turns on)/activation (green indicator turns on), the Electronic Parking Brake (EPB) is activated automatically.

Autonomous Emergency Braking (AEB)

The AEB (Autonomous Emergency Braking) is an assist device that warns the driver of the risk of collision when a collision with the front vehicle or pedestrian is expected by the sensor of the front sensor module (front camera module and front radar).

This system informs the driver about the collision risk with the warning message and warning buzzer according to the level of collision risk. If this collision risk persists, this system controls the braking force to avoid collision or relieves the shock when a collision occurs, improving the safety of the driver and pedestrians.

1st collision alert → 2nd collision warning → 3rd emergency braking → Vehicle stop



Warning

- **AEBS is only an auxiliary system for helping the driver to secure safety in a dangerous situation and it does not avoid a collision situation automatically. The driver is responsible for the vehicle safety and control.**

Notice

- **The AEBS is set and Medium is set for the sensitivity of the forward collision warning as the factory default settings.**

AEB indicator/warning light

AEB OFF indicator

AEBS OFF

When the AEBS system and the ESC function are deactivated, the AEBS OFF indicator on the instrument cluster turns on.

Notice

- **Pressing and holding down the ESC OFF switch for 3 seconds turns on the ESC OFF indicator and the AEBS OFF indicator at the same time, and the ESC function and the AEBS function are deactivated.**

AEB indicator/warning light



The AEB indicator and warning light operate as follows depending on the AEB status.

- Blink: AEB is operating
- Turn on: AEB is abnormal

A warning message is displayed on the display of the instrument cluster as follows according to the AEBS status.

AEB is operating



AEB is abnormal



AEB is activated

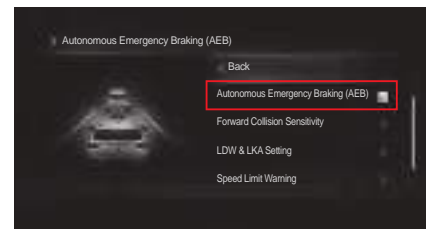

When you put a check mark on  (User Settings) → **Driving assist** → **AEB** from the instrument cluster, the function is activated and the AEBS OFF indicator on the instrument cluster turns off.

When you remove the check mark from the **AEB**, the function is deactivated and the AEBS OFF indicator turns on.

Caution

- **Activate or deactivate the AEBS system before driving the vehicle or after stopping the vehicle at a safe place for safety.**
- **When the ESC function is deactivated, the AEB function is also deactivated automatically even if it was activated previously. The AEB function can also be activated from the User Settings menu on the instrument cluster.**

Setting the sensitivity of the forward collision warning

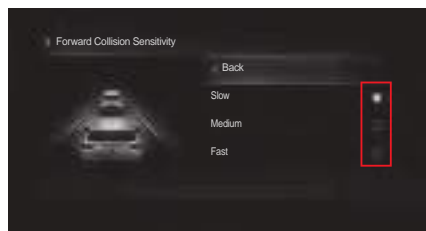





You can change the setting from  (User Settings) → **Driving assist** → **Forward Collision Sensitivity** on the instrument cluster.

- If **Fast** is set, the AEB warning is issued fast.
- If the AEB warning is too fast, set it to **Medium** or **Slow**.

Caution

- Even if **Fast** is set for the sensitivity of the AEB warning, you may feel it is slow when a front vehicle applies a sudden braking.

AEBS operation

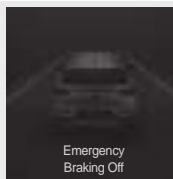
	Collision alert (1st warning)	Collision alert (2nd warning)	Emergency braking (3rd warning)	Vehicle stop
Classification				
Display window of the instrument cluster				
Warning buzzer	Sounds 7 beeps for 1 second			-
Vehicle control	-	-	Full brake control before collision.	Maintain the braking force for approximately 2 seconds after the vehicle stops.



Warning

- The AEB is an auxiliary system that helps the driver to secure safety in a dangerous situation and it does not guarantee safety.
- The AEB does not recognize all urgent and dangerous situations.
- Do not attempt dangerous driving for activating the AEB.
- The AEB does not avoid a collision situation automatically. The driver is responsible for the vehicle safety and control.
- Always secure safe braking distance and depress the brake pedal to reduce the vehicle speed if necessary.
- The AEB is activated according to the distance from a front vehicle or a pedestrian, relative speed and the driver's response.
- The AEB detects the driving situation through the front sensor module (front camera module and front radar). If the driving situation is not covered by the front camera, the performance of the system may deteriorate.

Activation conditions

When the following conditions are met after the AEB is activated, the system operates normally.

- When the AEB is activated
- When the Electronic stability control system (ESC) is activated
- When the Front Camera Module (FCM) recognizes a vehicle and a pedestrian at the front normally
- When the vehicle speed is between 8 km/h and 60 km/h

Notice

- The AEB is ready to operate in preparation of an urgent (dangerous) situation and when the driver depresses the brake pedal, this auxiliary system responds promptly.
- When the AEB is activated, it supplements the optimal braking force required for decelerating the vehicle.
- If the urgent (dangerous) situation is cleared, the AEB control stops.
- The 1st warning is activated up to the vehicle speed of 180 km/h.

Deactivation conditions

When the following conditions are met after the AEB is activated, the system is deactivated and the AEB does not operate.

- When the AEB is deactivated
- When the Electronic stability control system (ESC) is deactivated
- When the vehicle speed exceeds 60 km/h
- When the steering wheel is operated
- When the gear shift lever is placed in the P (parking) or the R (reverse) position
- When the accelerator pedal is depressed

The AEB cannot detect a vehicle properly:

- on a sharply curved section or a steeply sloping road
- when the vehicle wobbles significantly
- when the tail lights of a front vehicle are asymmetrical or are not turned on at night
- when the rear side of a front vehicle is asymmetrical
- when a vehicle cuts in suddenly
- An animal, an object or a vehicle driving, or when the vehicle is driving in the opposite direction
- An approaching vehicle or a vehicle that is reversing
- An odd-shaped front vehicle
- When there is rapid change of illumination (tunnel entrance, etc.)
- When the shape is not visible due to shade right below an overpass

- There is poor visibility due to bad weather such as snow, rain and fog
- When the moisture formed on the glass of the windshield is not removed completely
- When the reflection from an object placed on the dashboard panel obstructs the recognition of the Front Camera Module (FCM)
- When there is a narrow object such as a motor cycle or a bicycle in front of the vehicle
- A vehicle moving or stopping perpendicularly to the driving direction at an intersection



Caution

- **The driver's attention is required since the AEB may not respond normally or the system may malfunction when it is difficult to detect a vehicle.**

Curved road



On a curved road, a front vehicle on the same lane cannot be detected and the AEB performance is reduced so that unnecessary warning or braking is applied or the system may not operate.

Check the front road and driving conditions on a curved road and adjust the vehicle speed directly by depressing the brake pedal if necessary.



A vehicle on another lane may be detected, affecting the speed. Check the front road and driving conditions and adjust the vehicle speed directly by depressing the brake pedal if necessary.

In such case, you can prevent unnecessary deceleration by depressing the accelerator pedal.

Sloping road



On a uphill road or a downhill road, a vehicle on the same lane cannot be detected and the AEBS performance is lowered so that unnecessary warning or braking is applied or the system may not operate.

Also, a front vehicle is detected suddenly and the warning and braking may be applied.

Check the front road and driving conditions on a uphill road or a downhill road and adjust the vehicle speed directly by depressing the brake pedal if necessary.

When changing the lane

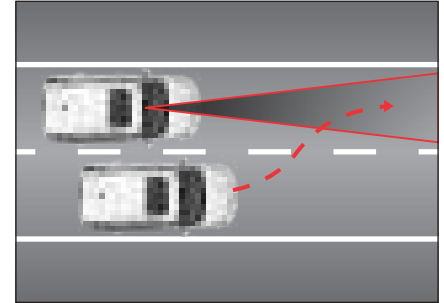

When a vehicle on the next lane changes the lane to the same lane, the vehicle may not be detected until it enters the detection range of the Front Camera Module (FCM).

Always pay attention since a vehicle that cuts in suddenly may be detected late.

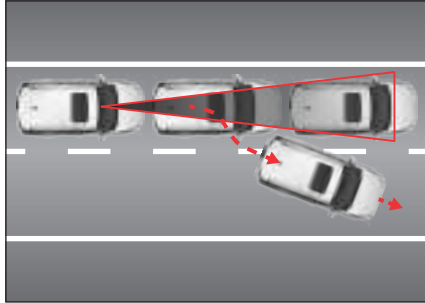

Caution should be taken that if there is a vehicle stopped in front of the vehicle ahead and the vehicle ahead moves out of the lane while your vehicle has been decelerated due to the AEBS operation, the vehicle stopped at the front is not selected as the control target, causing a collision risk.

Recognition of a vehicle ahead

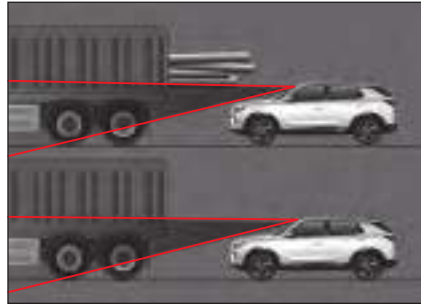

Caution should be taken that a tall vehicle or a vehicle with cargo sticking out the back of the vehicle may cause a dangerous situation.

The AEBS cannot detect a pedestrian

- who is not standing normally
- whose body is hidden or who does not walk upright
- who moves fast
- who cuts in suddenly
- who wears clothes in a color similar to the background
- when the surrounding illumination intensity is too high or too low
- at night or when the surrounding area is dark
- if there is a structure similar to a person
- if he/she is short
- whose behavior is unstable
- When there is a situation that disables the AEBS to detect a pedestrian by environments
- when there are many people gathered together
- When there is an object (cart, bicycle, two-wheeler, suitcase, stroller, etc) pushed by the pedestrian

Warning

- The AEBS is not activated in all situations. Therefore, do not test the AEBS targeting a person or an object. Doing so may cause serious injury or death.
- When you start the vehicle, the AEBS is always activated automatically. If you need to deactivate the function, use the User Settings menu on the instrument cluster.
- If the AEBS is activated and you apply a sudden braking, occupants in the vehicle may face danger. Therefore, always pay attention just in case.
- If the front camera is stained with foreign materials, its detection function is lowered and the AEBS is deactivated temporarily. Always keep the camera clean.
- If the front camera has deviated from its normal position due to a shock, the system may not operate normally even if the warning light does not turn on or the warning message is not displayed on the instrument cluster.
- At night, the vehicle and pedestrian detection performance may be lowered since the lighting condition is poor in comparison to daytime.
- If frost forms on the windshield during winter, the front camera may not detect normally. Be sure to remove the frost.

- Failure to do so may result in unnecessary warning and braking, and the warning and braking may not be applied due to the detection limitation of the sensor.
- If a vehicle ahead applies a sudden braking, proper brake application may not be carried out, causing a collision. Always pay attention in preparation for a dangerous situation.
- If you tow another vehicle or a trailer, cancel the AEBS setting. Applying braking while towing may lower the safety of the vehicle.
- When you load the vehicle on a truck, a train or a ship that transports a vehicle, deactivate the AEBS. The system may be activated according to the contact condition in the loading process.

Caution

- The AEBS may be deactivated temporarily by a strong electromagnetic wave.
- Do not tint the Front Camera Module (FCM) detection area. Doing so may cause the relevant system to malfunction or not to operate.

Part prohibited for tinting (FCM detection area)



Rear and side warning system*

The rear and side warning system is an auxiliary system that detects and informs the blind spot area that cannot be detected by the driver using the detection sensor located inside of both edges of the rear bumper.

- The rear and side warning system includes the following warning systems.
 - Blind spot-detection warning (BSW)
 - Lane change warning (LCW)
 - Rear cross traffic warning (RCTW)
 - Rear cross traffic-collision assist (RCTA)
 - Safety exit warning (SEW)

Display of rear and side warning system activation



When the outside rearview mirror warning light blinks twice with the START/STOP switch in the ON status or while the vehicle is running, it indicates that the rear and side warning system is operating normally.

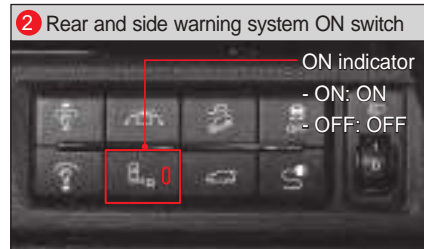

When you turn off the vehicle with the rear and side warning system deactivated and set the START/STOP switch to the ON status, the system turns on without returning to the previous status.

Warning

- The rear and side warning system is an auxiliary system that helps the driver to drive the vehicle safely. Avoid depending on the rear and side warning system in any case and drive the vehicle while checking the road condition.

Caution

- Always keep the rear bumper clean. The sensor that detects the rear and both sides of the vehicle is installed inside of both edges of the rear bumper. If the rear bumper is stained with foreign materials, the sensors may not function normally.
- When the rear bumper is replaced, painted or repaired, the system operation performance may be lowered.
- The detection sensors of the system may not operate depending on the surrounding environment. Drive the vehicle while checking the road condition directly for an emergency situation.
- Failure to do so may cause the system to malfunction due to a strong electromagnetic wave.

Activating/deactivating the warning buzzer of the rear and side warning system

The alarm sounds when operating the system with the "RCTW" set (ticked) under User Settings in the instrument cluster.

- Tick Instrument **Cluster Setup** → **Sound** → **RCTW** → **Enable RCTW** under  (User Settings) in the instrument cluster.

Notice
<ul style="list-style-type: none">• The BSW switch is applied to only the BSW (Blind Spot Warning) / LCW (Lane Change Warning). For other functions, refer to "Instrument Cluster Setup".• The message indicating whether the RCTW is enabled or disabled is displayed on the top of the instrument cluster display. In addition, the warning lamp for the outside rearview mirror flashes twice.• If you do not use the rear and side warning system, be sure to deactivate the system.• If you wish to connect a trailer, be sure to deactivate the system for preventing a system malfunction.

Warning level of the rear and side warning system

When a blind spot on the rear left or right side of the vehicle or a vehicle approaching at a fast speed is detected with the blind spot detection and lane change assist system function activated and the driving speed is approximately 30 km/h or more, the rear and side warning system is activated.

1st warning

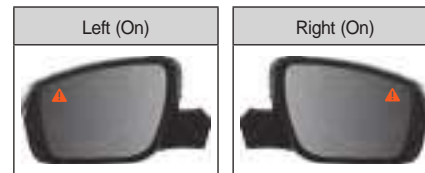

When a vehicle in the rear and side warning area of the vehicle is detected, the yellow warning light indicator on the outside rearview mirror turns on.

When the relevant vehicle deviates the warning area during the operation of the 1st warning, the warning operation is stopped according to the driving condition after a certain period of time.

- Yellow warning lamp flashes on outside rearview mirror

2nd warning



When you operate the turn signal with the 1st warning (Yellow warning light on the outside rearview mirror turns on), the 2nd warning is operated as follows.

- Yellow warning light on the outside rearview mirror blinks
- Warning buzzer sounds inside the vehicle.

When you return the turn signal switch to its original position (OFF status) during the operation of the 2nd warning, the second warning operation is stopped.

When the rear and side warning system is abnormal

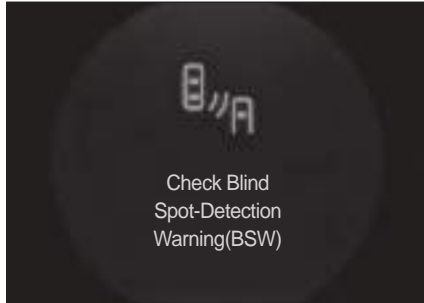

When the rear and side warning system is abnormal, a warning message is displayed on the display of the instrument cluster.



Caution

- When the warning message on the faulty RCTW is displayed, all the RCTW relevant functions are disabled.
- If the warning message persists, have your vehicle checked and serviced at a KG Mobility Authorized Service Center.

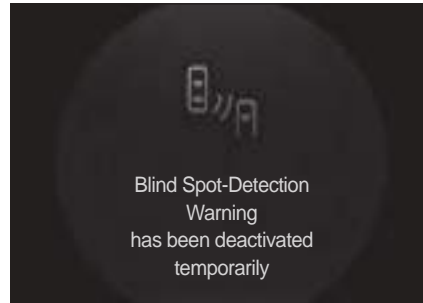

If the sensor cannot detect the rear and both side areas of the vehicle normally with the rear and side warning system activated, the message is displayed on the display of the instrument cluster.

- When there is a foreign material on the outside and inside of the rear bumper
- When equipment such as a trailer is installed on the rear of the vehicle
- When driving on open area where no objects around road continuously (e.g., desert, meadow)
- When there is a heavy snow or a heavy rain
- When the width of the road is wide

Blind Spot Warning (BSW) system

The BSW system detects a vehicle approaching the blind spot on the rear and both sides of the vehicle and informs it to the driver by turning on the outside rearview mirror warning light.

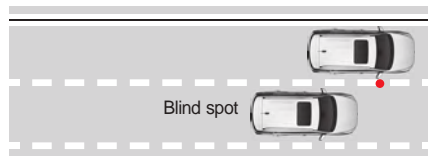

Activation conditions

The BSW system is activated when the following conditions are met.

- When the rear and side warning system is activated
- When the vehicle speed is more than 30 km/h and less than 255 km/h
- When a vehicle is present in the blind spot detection area



Warning

- **The Blind Spot Warning (BSW) system can only give a warning in a limited area and the warning function may not operate for a vehicle approaching the rear blind spot depending on the surrounding situation and driving conditions.**

Lane Change Warning (LCW) system

The LCW (Lane Change Warning) system is designed to alert the driver by flashing the outside rearview mirror and sounding the beep when a fast approaching vehicle is detected from the rear side of the driver's vehicle.

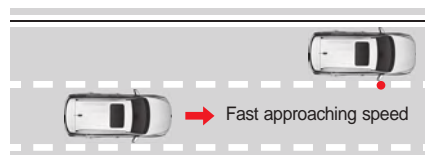

Operating conditions

The LCW system activates the warning system when the following conditions are met:

- BSW system is activated.
- Vehicle speed is between 30km/h and 255km/h.
- When a vehicle approaching at a high speed is in the detection area.
- Driver's vehicle is driving on a straight road.



Warning

- **This system is an aid to ensure the driver convenience. If you depend on this system, it may cause accidents. Always check the surroundings with a side mirror when changing lanes.**

RCTW System

The RCTW (Rear Cross Traffic Warning) system is a system that, when a vehicle is detected approaching from the rear left/right side during reversing the vehicle, displays a warning message in the instrument panel display window, sounds a audible alert and illuminates the warning lamp in the outside rearview mirrors to inform the driver.

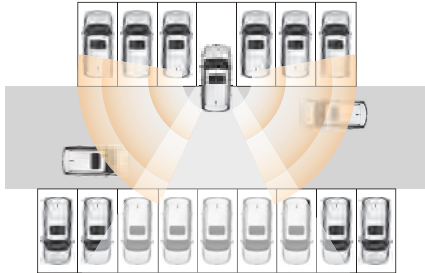

Activating / deactivating RCTW system

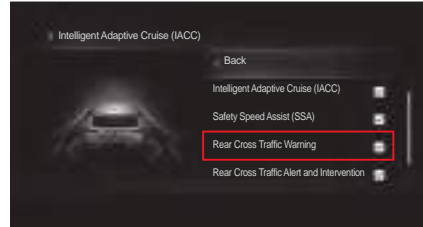

- Go to **Driving Assist Setting** → **Blind-Spot Collision Assist** → **Blind Spot Detection & Collision Assist** → **Enable Collision Warning** in  (User Settings) in the instrument cluster and tick the check box.

Activation conditions

- RCTW system is activated
- If the gear shift lever is placed in the R (reverse) position
- When the vehicle speed is less than 10km/h
- If a vehicle exists within the RCTW range and the speed of the approaching vehicle is 24 km/h or less

If an approaching vehicle is detected, the approach message from the relevant side is on the display of the instrument cluster.



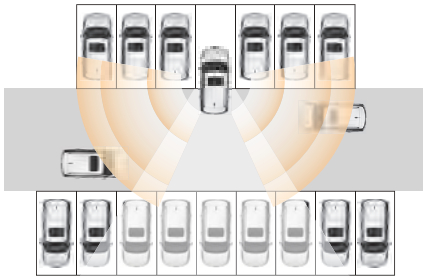

RCTA System

The RCTA (Rear Cross Traffic-collision Assist) system is an assistive device that outputs a warning message and a buzzer to inform the driver of risk of collision due to a vehicle approaching to your side when backing up and help collision avoidance or mitigate damage by applying brake assist.

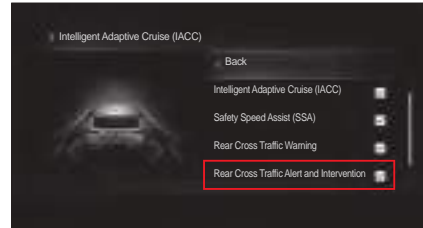

Activating / deactivating RCTA system



- Go to **Driving Assist Setting** → **Blind-Spot Collision Assist** → **Blind Spot Detection & Collision Assist** → **Enable Collision Assist** in  (User Settings) in the instrument cluster and tick the check box.

Operating conditions:

- Shift lever in R (reverse) position
- Vehicle speed of below 8 km/h
- Vehicle in warning area with approaching speed of less than 24 km/h

If the risk of collision is detected due to an approaching vehicle during operation of the RCTA system, emergency braking (braking assist) is performed.

- The braking assist does not restart for about 10 seconds after it operates.



Note

- **This system may not function depending on the operation of ESC system.**
 - When ESC warning lamp light up
 - When ESC system is operating

Cases where RCTA system not work

In any of the following cases, the RCTA may not operate.

- If the target vehicle is out of the RCTA detection area
- If the target vehicle is right behind
- If the target vehicle is moving in the same direction
- If the speed of the target vehicle is fast
- If the speed of the target vehicle decreases suddenly
- If the detection sensor is covered with an obstacle

Cases where the RCTA system malfunctions

In any of the following cases, the system may malfunction, so the driver's attention is necessary.

- If the rear bumper is stained with foreign materials (rain, snow, dust, sticker, etc)
- When equipment such as a trailer is installed on the rear of the vehicle

- When the rear bumper is damaged or the vehicle body is distorted
- Sharp curve, tollgate entrance and exit section
- Tire pressure imbalance and excessive loading
- Bad (heavy snow, heavy rain) weather
- When there is a fixed object (median strips, guardrails, noise barriers) on the road or a construction section
- When a large vehicle or a small motor cycle (bicycle) is driving at a close range
- When your vehicle is passing by heavy-duty trailer
- When you accelerate the vehicle with an opposite vehicle together at the same time
- When the speed of a vehicle behind is very fast (passing)
- When you change the lane
- Steep uphill road, downhill road or a road condition where the height of lanes is different
- When an opposite vehicle is driving very closely to the rear side of the vehicle
- When a vehicle behind driving closely passes
- When the area near the sensor is covered with a vehicle, a column or a wall in the parking lot
- A vehicle that moves in the same direction when reversing the vehicle
- A small moving object such as a person, a shopping cart or a stroller

- When parking conditions are complicated (diagonal parking, near the ramp, obstacle, etc.)
- A vehicle with very low vehicle body
- A narrow road densely covered with trees or grass
- When the width of the road is very wide
- When the road surface is wet
- When the sensor detection area is changed due to a rear collision

Warning

- **The Rear Cross Traffic Warning (RCTW) system does not give a warning for an article adjacent to the vehicle and the warning function may not be activated for a vehicle approaching fast in the rear.**
- **The BSW and RCTW are assistive devices for the driver, not the safety devices. If you depend on these systems, it may cause accidents. The driver is responsible for safe driving of the vehicle by maneuvering the brake pedal. Depending on the surrounding environment and driving conditions, the warning and control functions of the system may not operate or may operate unnecessarily. Always check the surroundings while driving.**

SEW System

The SEW (Safety Exit Warning) system is an assistive device that warns the driver and passengers about the risk of an accident by displaying a warning message on the instrument panel along with a buzzer when there is a vehicle approaching from the rear side when the driver or passenger is getting off the vehicle.

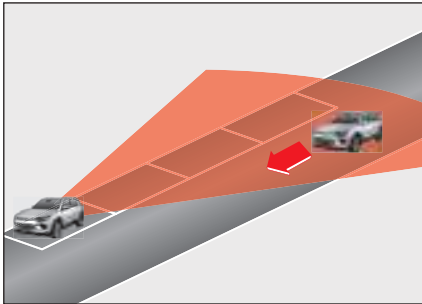

Caution

- The exit assist function operates for about 10 minutes after the ignition switch is turned off. After about 10 minutes, the exit assist function does not work to prevent battery drain.
- When you lock the door with a smart key, the exit assist function will not work immediately.

Activating / deactivating SEW system

- Go to **Driving Assist Setting** → **Blind-Spot Collision Assist** → **Enable SEW** in  (User Settings) in the instrument cluster and tick the check box.

Operating conditions:

- Shift lever in P (park) or N (neutral) position
- Vehicle parked
- You are about to open the door to leave the vehicle when a vehicle is approaching from the rear side

If a vehicle approaching from the rear side is detected, a warning message is displayed on the instrument panel display along with a buzzer to inform the driver and the passenger.

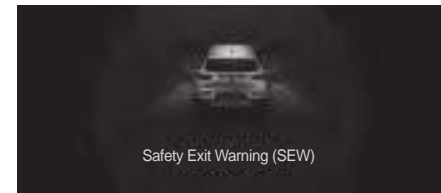
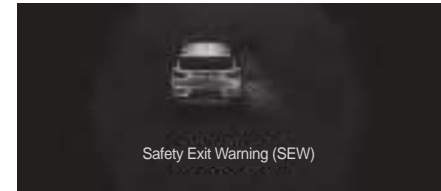

LDW (Lane Departure Warning)

The LDW is a driving assist system that its Front Camera Module (FCM) detects the lanes ahead and issues a warning message and sounds the warning buzzer to help the driver to drive the vehicle while maintaining the vehicle on the line properly when the vehicle deviates from the lane with the turn signal not activated.

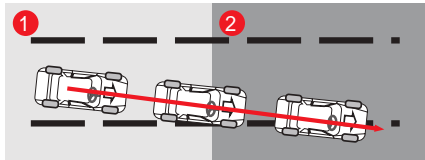



- 1 Detect the deviation of the lane with the turn signal not activated
- 2 Display a warning message and sound the warning buzzer

Warning

- The LDW prevents the lane departure, gives a warning to the driver and sounds the warning buzzer. Never depend on the lane departure warning system in any case and drive while checking the road condition.

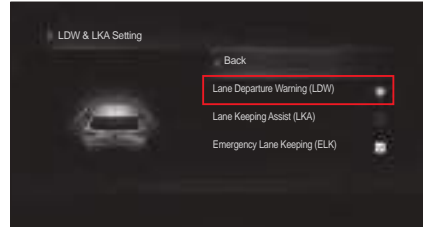
To activate / deactivate lane departure warning (LDW)



- Go to Driving Assist Setting → Forward Safety Assist → Enable LKAS in  (User Settings) in the instrument cluster and tick the check box of Lane Departure Warning (LDW).

Activating/deactivating the LDW

With the START/STOP switch in the ON status, press the lane departure warning system switch to activate the system. When the system is activated, the lane departure warning indicator on the instrument cluster turns on.

Pressing the switch again with the lane departure warning system activated deactivates the system and the lane departure warning indicator turns off.



LDW ON indicator



When the lane departure warning system is activated, the indicator on the instrument cluster turns on.

- White indicator turns on: The lane departure warning system is in ready status (the vehicle speed is below a prescribed speed or the lane is not recognized).
- Green indicator turns on: The lane departure warning system is operating normally.
- Yellow warning light turns on/blinks: When the LDW is abnormal

Activation conditions

If the following conditions are met, the LDW is activated.

- When the LDW is set
- When the vehicle speed is between 40 kph and 155 kph
- When the front camera recognizes the left and right lanes
- A straight road or gently curved road

 Refer to "LKA (LDW) indicator / warning lamp" (p.4-30)

Notice

- **Entry and release conditions depending on vehicle speed**
 - **Entry conditions: 40 kph or above, 155 kph or less**
 - **Release conditions: 35 kph or less, 165 kph or above**

Warning

- **Be sure to hold the steering wheel while driving.**
- **The driver is responsible for operating the steering wheel to ensure the safe driving of the vehicle.**
- **Do not steer the vehicle rapidly when the lane departure warning system is activated.**
- **The lane departure warning system only gives a warning and sounds the warning buzzer. Therefore, the driver should keep the vehicle in the lane by steering the vehicle carefully while driving.**
- **The lane departure warning system may be deactivated, may not operate or may operate unnecessarily according to road condition and surrounding environment. Therefore, pay attention while driving.**
- **Do not attempt dangerous driving for activating the lane departure warning system.**



Caution

- Do not tint or attach a sticker or an accessory to the Front Camera Module (FCM) detection area. Doing so may cause the relevant system to malfunction or not to operate normally.
- The lane departure warning system recognizes a lane using the camera, and if the lane is not recognized properly, the system may be deactivated or may operate unnecessarily, so be careful when using the system.
- If the lane is not recognized properly, be sure to check the conditions for driver's attention.
- Do not detach any component from the LDW or apply an impact to the LDW.
- Do not place a reflecting object (white paper or mirror) on the dashboard. Doing so may cause the system to malfunction due to the reflection of light.
- The warning buzzer of the LDW may not be heard due to the loud sound from the audio system.

Message on instrument cluster

Both lane lines are detected



When both lane lines are detected while the vehicle is being driven at 40 km/h or more, both the lane markers on the display turns green.

Only one lane line is detected



When only one lane line is detected while the vehicle is being driven at 40 km/h or more, the corresponding lane marker on the display turns green.

Driving at low speed or both lane lines are not detected



When the vehicle is driven at less than 40 kph (low speed conditions) or both lane lines are not detected, the lane marker is shaded.

Approaching a lane line without a turn signal



It is activated when the turn signal is not activated or the vehicle deviates from center of the lane.

LDW cannot operate



This message is displayed when the LDW is unavailable.

System check in progress



This message is displayed when the LDW is being checked.

System OFF



This message is displayed when the LDW is deactivated.

Cases that the system is not activated

- When the turn signal and the hazard warning lamp are operated for changing the lane
- When both the left and right lanes are not recognized
- When the vehicle is driven on one side of the lane continuously without moving to the center of the lane after changing the lane
- If the steering wheel is operated suddenly for changing the lane (the system is not activated temporarily)
- When the Electronic stability control system (ESC) is activated
- When the vehicle is circling fast on a curved road
- When the vehicle speed is less than 35 kph and more than 165 kph
- When you need to change the lane rapidly
- When the width of the lane is too narrow or too wide so that the lane cannot be detected
- When there are 2 or more lane markings on the lane while driving (example: construction section)
- If the radius of a curved road is too small

- In case of a steep sloping road
- When the vehicle speed is reduced rapidly
- When the tinted part of the windshield covers a part of the Front Camera Module (FCM) detection range



Warning

- **Change the lane after operating the turn signal switch.**



Caution

- **Do not tint the Front Camera Module (FCM) detection area. Doing so may cause the relevant system to malfunction or not to operate.**

Part prohibited for tinting (FCM detection area)



Cases requiring the driver's attention

In any of the following cases, the system may not operate or may operate unnecessarily. Therefore, the driver's attention is necessary.

- If the lanes are not visible due to foreign substances (rain, snow, dust, puddle, wet road surface)
- If the color of lane markings and the road cannot be distinguished clearly
- If the lane markings are not clear or are damaged or two or more lane markings are present on one side
- If there are markings other than or similar to the lane marking near the lane
- If the lane markings are covered in the shade of median strips, guardrails, noise barriers, other structures or roadside trees
- If there are boundary structures such as sidewalk blocks
- If the lane is crowded due to the construction section or some lanes are replaced with structures
- When the lane suddenly disappears or is invisible on the intersection
- There is a section where the number of lanes increases or decreases or the lanes intersect complicatedly (tollgate entrance, road junction/merge section, etc)
- If the lane is too narrow or too wide
- If the distance from a vehicle ahead is extremely short or a vehicle ahead is driving while hiding the lane
- There is a marking for a crosswalk or road sign on the road surface
- If the visibility is poor due to bad weather such as fog, heavy rain or heavy snow
- If the visibility is poor so that the lane cannot be recognized
- When the brightness outside the vehicle changes rapidly such as the entering a tunnel
- When the light is weak or the head light of the vehicle is not used at night or in a tunnel section

- When you drive the vehicle on the bus-only lane or on the left or right lane of the bus-only lane
- On a sharply curved section or a steeply sloping road
- when the vehicle wobbles significantly
- When a reflecting object (white paper or mirror, etc.) is placed on the dashboard
- When the windshield or the front side of the camera lens is contaminated with dust
- When the moisture formed on the glass of the windshield is not removed completely
- When the temperature near the camera is very high due to direct sunlight
- When there is backlight in the moving direction of the vehicle
- When the sunlight, streetlight or the light from an incoming vehicle is reflected by water on the road surface
- When front camera is arbitrarily refitted (Be sure to visit our authorized service center to perform the calibration of the front camera. Otherwise, it may cause the camera to malfunction.)

Lane Keeping Assistance (LKA)

The LKA (Lane Keeping Assist) is an assistive vehicle operation technology that detects vehicles up ahead using the FCM (Front Camera Module), and when the system detects that the vehicle is departing from the current lane without a lane change indication, the vehicle visually and audibly warns the driver through the LDW (Lane Departure Warning), and if the vehicle continues to depart from the lane, the vehicle maintains stays in the current lane by taking control using the EPS (Electronic Power Steering) system.

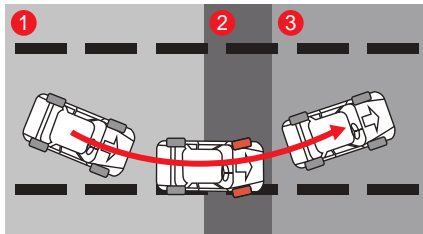

- 1 Lane departure without activation of turn signal lamp detected
- 2 Steering control by EPS as well as warning message and buzzer
- 3 The vehicle is steered toward the center of the lane.

Warning

- The LKA assists the driver with audible and visual warnings so that the vehicle does not move out of the driving lane unintentionally. Do not drive the vehicle in a dangerous or reckless manner relying on the LKA. Always drive safely paying attention to the road conditions.
- The LKA is an assistive device that precisely controls the steering wheel so that the vehicle does not leave the lane regardless of the intention of the driver.

To activate / deactivate lane keeping assistance (LKA)



- Go to Driving Assist Setting → Forward Safety Assist → Enable LKAS in (User Settings) in the instrument cluster and tick the check box of Lane Keeping Assist (LKA).

4

To enable / disable LKA

Press the LKA switch with the ignition switch turned on. If the system is activated, the LKA ON indicator lights up on the instrument cluster.

When the switch is pressed again with the LKA is in active, the system will be deactivated and the LKA ON indicator will go off.



LKA ON indicator



This indicator light up on the instrument cluster when the LKA is activated.

- Indicator ON in white: System READY state (Vehicle speed below specified value or no lane detected)
- Indicator ON in green: LKA operates normally
- Indicator ON in yellow / flash: Faulty LKA system

Operating conditions

The LKA system is activated when:

- LKA is enabled
- Vehicle travels at a speed between 40 kph and 155 kph
- Front camera recognizes left/right lanes
- Driving on a straight road or gentle curve
- Turn signal is not activated

☞ Refer to "LKA (LDW) indicator / warning lamp" (p.4-30)

Notice

- **Entry and release conditions depending on vehicle speed**
 - **Entry conditions:** 40 kph or above, 155 kph or less
 - **Release conditions:** 35 kph or less, 165 kph or above



Warning

- Do not release your hands from the steering wheel while driving.
- The driver is responsible for safe driving of the vehicle by maneuvering the steering wheel.
- Do not steer the vehicle rapidly while the LKA is activated.
- The LKA does not always control the steering wheel automatically.



Warning

- The LKA is only a device to assist with the steering wheel operation, and the driver is entirely responsible for maintaining the lane with the steering wheel operation.
- The LKA may be deactivated, not work at all, or activated when it is not desired depending on the road conditions and surrounding environment.
- Never drive the vehicle in a dangerous or reckless manner to test the LKA.
- When replacing the steering wheel system-relevant parts, have the system checked and serviced at a KG Mobility Dealer or KG Mobility Authorized Service Center.



Caution

- Do not attach sticker, accessory, tinting films on the detection area of the FCM. This can cause malfunctions and abnormal operation of the related systems.
- The LDW recognizes the lanes by using the images from the cameras. Keep in mind that the LDW may be deactivated or activated when it is not desired if the lanes are not recognized successfully.
- Pay close attention especially when the LKA fails to detect the lane markings.



Caution

- Do not remove any part of the LDW or apply impact on it.
- Do not put any object with reflective surface (white paper, mirror, etc.) on the instrument panel. Reflected lights can cause system malfunction.
- You may not hear the audible alert (chime) if the sound from your audio source is too loud.
- If you drive without holding the steering wheel for too long, LKA will be turned off automatically after the hands off alert.
- Please note that when driving at high speed, the steering assist force of the lane keeping assist system may be reduced, which can cause the vehicle to leave the lane.
- The driver is responsible for operating the steering wheel.
- The driver can still steer the vehicle in the event of the faulty LKA.
- Please operate the steering wheel by hand without using the LKA when:
 - Weather is bad
 - Road condition is not good
 - Frequent steering wheel control is required
- You may feel that the steering wheel is heavy or light when the LKA is not operating.

Message on instrument cluster

Both lane lines are detected



When both lane lines are detected while the vehicle is being driven at 40 km/h or more, both the lane markers on the display turns green.

4

Only one lane line is detected



When only one lane line is detected while the vehicle is being driven at 40 km/h or more, the corresponding lane marker on the display turns green.

Driving at low speed or both lane lines are not detected



When the vehicle is driven at less than 40 kph (low speed conditions) or both lane lines are not detected, the lane marker is shaded.

Approaching a lane line without a turn signal



If your vehicle approach either side of the lane without turning on the corresponding turn signal while the LKA is operating, the corresponding lane marker on the display will blink (green ↔ red).

LKA cannot operate



This message is displayed when the LKA is unavailable.

System check in progress

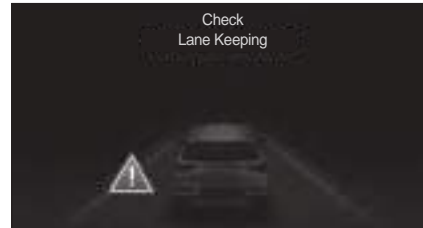

This message is displayed when the LKA is being checked.

System OFF



This message is displayed when the LKA is deactivated.

Cases that the system is not activated

- When the turn signal and the hazard warning lamp are operated for changing the lane
- When both the left and right lanes are not recognized
- When the vehicle is driven on one side of the lane continuously without moving to the center of the lane after changing the lane
- If the steering wheel is operated suddenly for changing the lane (the system is not activated temporarily)
- When the Electronic stability control system (ESC) is activated
- When the vehicle is circling fast on a curved road
- When the vehicle speed is less than 35 kph and more than 165 kph
- When you need to change the lane rapidly
- When the width of the lane is too narrow or too wide so that the lane cannot be detected
- When there are 2 or more lane markings on the lane while driving (example: construction section)
- If the radius of a curved road is too small

- In case of a steep sloping road
- When the vehicle speed is reduced rapidly
- When the tinted part of the windshield covers a part of the Front Camera Module (FCM) detection range

Warning

- **Change the lane after operating the turn signal switch.**

Caution

- **Do not tint the Front Camera Module (FCM) detection area. Doing so may cause the relevant system to malfunction or not to operate.**

Part prohibited for tinting (FCM detection area)



Cases requiring the driver's attention

In any of the following cases, the system may not operate or may operate unnecessarily. Therefore, the driver's attention is necessary.

- If the lanes are not visible due to foreign substances (rain, snow, dust, puddle, wet road surface)
- If the color of lane markings and the road cannot be distinguished clearly
- If the lane markings are not clear or are damaged or two or more lane markings are present on one side
- If there are markings other than or similar to the lane marking near the lane
- If the lane markings are covered in the shade of median strips, guardrails, noise barriers, other structures or roadside trees
- If there are boundary structures such as sidewalk blocks
- If the lane is crowded due to the construction section or some lanes are replaced with structures

- When the lane suddenly disappears or is invisible on the intersection
- There is a section where the number of lanes increases or decreases or the lanes intersect complicatedly (tollgate entrance, road junction/merge section, etc)
- If the lane is too narrow or too wide
- If the distance from a vehicle ahead is extremely short or a vehicle ahead is driving while hiding the lane
- There is a marking for a crosswalk or road sign on the road surface
- If the visibility is poor due to bad weather such as fog, heavy rain or heavy snow
- If the visibility is poor so that the lane cannot be recognized
- When the brightness outside the vehicle changes rapidly such as the entering a tunnel
- When the light is weak or the head light of the vehicle is not used at night or in a tunnel section
- When you drive the vehicle on the bus-only lane or on the left or right lane of the bus-only lane
- On a sharply curved section or a steeply sloping road
 - when the vehicle wobbles significantly
- When a reflecting object (white paper or mirror, etc.) is placed on the dashboard
- When the windshield or the front side of the camera lens is contaminated with dust
- When the moisture formed on the glass of the windshield is not removed completely
- When the temperature near the camera is very high due to direct sunlight
- When there is backlight in the moving direction of the vehicle
- When the sunlight, streetlight or the light from an incoming vehicle is reflected by water on the road surface
- When front camera is arbitrarily refitted (Be sure to visit our authorized service center to perform the calibration of the front camera. Otherwise, it may cause the camera to malfunction.)

ELK (Emergency Lane Keeping)

RKA-ROADEDGE (Lane Keeping Assist-Roadedge)

The RKA-ROADEDGE (Lane Keeping Assist-Roadedge) is a driving assistance system that helps the driver's vehicle maintain a Road-edge through the steering wheel (EPS) control if the front camera module (FCM) recognizes the left and right roads in front and the driver's vehicle departs the Road-edge without using a turn signal in that direction.

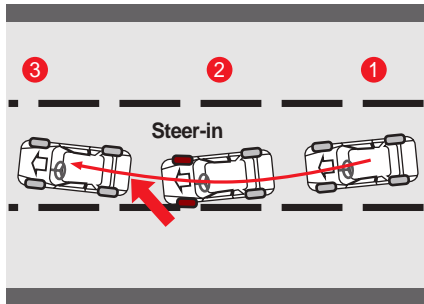

- 1 Road-edge departure detected with no turn signal operated
- 2 EPS steering control
- 3 Vehicle enters middle of driving road

Warning

- RKA-ROADEDGE is an assist system to precisely control the steering wheel so that the driver's vehicle does not leave the Road-edge, regardless of the driver's intention.

Activation / Deactivation

To activate ELK : Turn the ignition switch on.

To deactivate ELK : Please untick "ELK" in the User Settings on the instrument cluster.

Operating conditions

The RKA-Roadedge system is activated when:

- Vehicle travels at a speed between 60 km/h and 155 km/h
- Front camera recognizes left/right Road-edge
- Driving on a straight road or gentle curve
- Turn signal is not activated

Warning

- Do not release your hands from the steering wheel while driving.
- The driver is responsible for safe driving of the vehicle by maneuvering the steering wheel.
- The RKA-Roadedge does not always control the steering wheel automatically.

Warning

- The RKA-Roadedge may be deactivated, not work at all, or activated when it is not desired depending on the road conditions and surrounding environment.
- Never drive the vehicle in a dangerous or reckless manner to test the RKA-Roadedge.
- When replacing the steering wheel system-relevant parts, have the system checked and serviced at a KG Mobility Dealer or KG Mobility Authorized Service Center.

! Caution

- Do not attach sticker, accessory, tinting films on the detection area of the FCM. This can cause malfunctions and abnormal operation of the related systems.
- The RKA-Roadedge recognizes the Road-edge by using the images from the cameras. Keep in mind that the RKA-Roadedge may be deactivated or activated when it is not desired if the Road-edge are not recognized successfully.

! Caution

- Do not remove any part of the RKA-Roadedge or apply impact on it.
- Do not put any object with reflective surface (white paper, mirror, etc.) on the instrument panel. Reflected lights can cause system malfunction.
- Please note that when driving at high speed, the steering assist force of the RKA-Roadedge may be reduced, which can cause the vehicle to leave the Road-edge.

Does not work when:

- The driver activates the turn signal lamps or hazard warning lamp.
- The vehicle keeps being driven too close to any side of the lane after changing the lane.
- The driver changes the lane with abrupt steering wheel operation. (temporarily system inactivated)
- ESC (Electronic Stability Control) system is activated.
- The vehicle is cornering at high speed.
- Vehicle speed is below 55 km/h or above 165 km/h
- The driver changes the lane abruptly.
- The lane is too narrow or too wide to recognize it.
- The vehicle is driven around a curve with too small radius.
- The vehicle is driven on steep hills.
- The vehicle decelerates abruptly.
- The windshield tinting film covers the detection range of the front camera module (FCM).

! Warning

- Activate the turn signal lamps before trying to make a lane-change.

! Caution

- Do not apply tinting film on the FCM detection area. This may cause the related system to malfunction or not work.

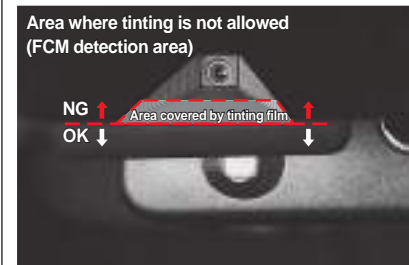

Driver Attention Required

The RKA-ROADEDGE may not work at all or be activated when it is not desired in the following conditions:

- The system cannot recognize the Road-edge markings because of rain, snow, dust, standing water or puddles, other obstruction on the road.
- The color of the Road-edge markings is not clearly distinct from the road color.
- The Road-edge markings are not clear.
- The Road-edge markings are covered in shadows of the median barriers, guardrails, noise barrier walls, roadside trees.
- There are environmental barriers, such as bollard.
- The Road-edge markings are suddenly discontinued at roundabouts and road intersections.
- The vehicle is passing through a certain section, such as highway interchange, where the number of lanes increases or decreases.
- The distance to the vehicle ahead is too short or a wheel of the vehicle ahead is touching the Road-edge marker.
- Poor visibility due to factors such as fog, heavy rain, heavy snow, etc.
- There is rapid change of illumination, for example at tunnel entry and exit points
- The headlamps are not turned on or the brightness of the lamps is too low when driving at night or through tunnels.
- The vehicle is driven on a steep hill or around sharp corners.
- The vehicle is driven under specific conditions which cause severe vibration.
- Objects with reflective surface (white paper, mirror, etc.) are on the dashboard.
- The windshield glass in front of the camera module is covered with ice, snow, slush, mud, dirt or debris.
- Fog or mist on the windshield.
- The temperature around the front view camera is too high because of the direct sunlight.
- The vehicle is moving towards a light source.
- The light from the sun, streetlamps, or headlamps of oncoming vehicles is reflected by the wet road surface.

RKA-ONCOMING(Lane Keeping Assist-Oncoming)

RKA-Oncoming function will help warn and control the vehicle depending on collision level: 'Collision Warning' and 'Emergency Steering'.

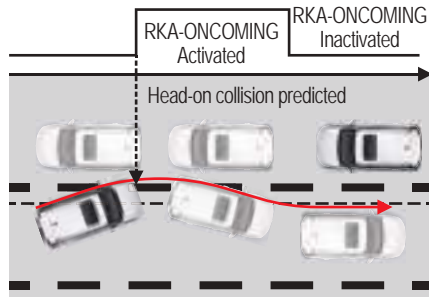

Activation / Deactivation

To activate ELK : Turn the ignition switch on.

To deactivate ELK : Please untick "ELK" in the User Settings on the instrument cluster.

Warning

- Emergency Steering
- To warn the driver that emergency steering will be assisted, the 'Emergency Steering' warning message will appear on the cluster
- The system will operate when your vehicle speed is between approximately 60~155 km/h
- In emergency steering situation, steering is assisted by the system to help prevent collision with the oncoming vehicle.

Caution

- The steering wheel may turn automatically when emergency steering is operating.
- Emergency steering will automatically cancel when risk factors disappear. If necessary, the driver must steer the vehicle.
- Emergency steering may not operate or may cancel during operation if the steering wheel is held tight or steered in the opposite direction.
- Evasive steering assist may not operate if space to avoid collision in the driving lane is insufficient.

FVSA (Front Vehicle Start Alarm)*

It is a system that notifies the driver when the driver does not recognize that the ahead vehicle departed while the driver's vehicle is stationary, using the sensor (FCM) at front of the vehicle.

FVSA : Front Vehicle Start Alarm

How To Set

You can enable (check) or disable (uncheck) this feature under the instrument cluster main menu, "User Settings > Driving Assist > Front Vehicle Depart Alert" with the vehicle turned on.

Operation

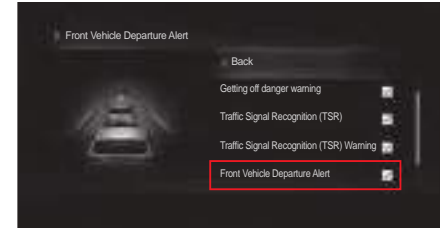

If the driver does not perform any operation (such as not starting the vehicle) about 1 second after the ahead vehicle departs, the message will be displayed on the LCD and alarm will sound.

4

Caution

- For safe driving, be sure to check the front and surrounding road conditions before starting the vehicle.
- The front vehicle departure warning (FVSW) function does not operate unless the brake pedal is applied to stop.
- If you stop the vehicle with shift lever in N (neutral) position, it may not operate or may generate a false alarm.
- In an environment other than the normal driving situation (non-motorway / highway), it may generate a false alarm.
- The FVSW works only when the shift lever is in D (drive) or N (neutral) position.
- There may be a false alarm if you stop at a speed bump or ramp.

TSR (Traffic signal recognition)*

It is the system which recognizes the speed limit of the traffic sign and other major signs.



Setting

Driver can set the function on the instrument cluster (Cluster Setting → Driving Assist) when the vehicle is switched on.

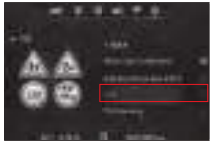

Notice

Recognizable Signs

- Vienna convention sign
- Standard traffic sign, Electronic sign, Prism sign



Caution

- TSR does not recognize all signs.
- It is possible that recognition is not available due to location, color or dents of sign.

Parking assist system*

Front/rear obstacle detection system

The front/rear obstacle detection system is a parking assist system that detects an obstacle through the ultrasonic sensor installed on the bumper and informs the driver with a warning buzzer when the driver places the SBW (shift by wire) in the D (driving) or the R (reverse) position and drives the vehicle.

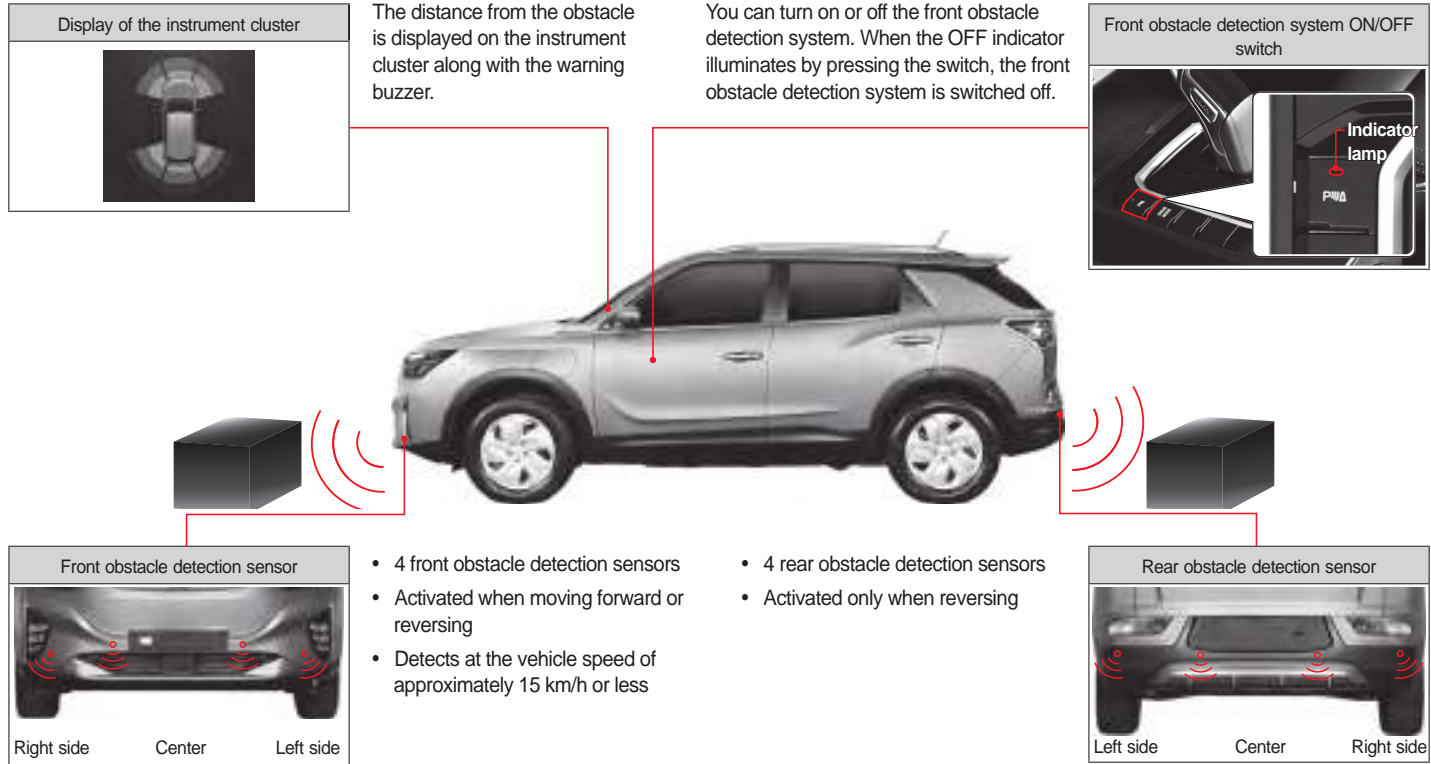

Activating the obstacle detection system

When an obstacle is detected through the front/rear obstacle detection sensor, the distance from the obstacle and the direction are displayed along with a warning buzzer according to the detected distance.

Notice

- **The sound volume of the parking assist system can be adjusted from  (User Settings) → Sound → Sound volume of parking assist system (PAS) on the instrument cluster and it can be adjusted between level 0 and level 3.**

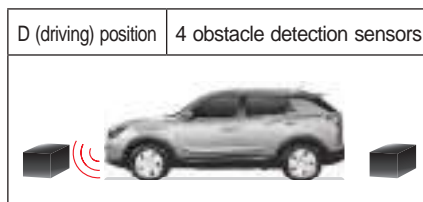

If you tick the box of “Parking Distance Warning Auto On” in the User Settings of the instrument panel, the front obstacle detection sensor will operate when:

- The vehicle speed exceeds 15 km/h. (It will turn off at vehicle speed of 10 km/h or lower)
- The vehicle starts to move after initial start.
- Even if the gear selector lever is switched to the R (reverse) position and then to the P (park), N (neutral) or D (drive) position while the front parking assist warning ON/OFF switch is in the OFF position (indicator on), the switch remains in the OFF position.
- When the gear selector lever is in the R (reverse) position with the front parking assist warning ON/OFF switch in the OFF position (indicator off), the front obstacle detection sensor is activated.

If you untick the box of “Parking Distance Warning Auto On” in the User Settings of the instrument panel, the front obstacle detection sensor will operate when:

- The vehicle starts to move after initial start (at vehicle speed of 15 km/h or lower).
- The transmission selector lever is changed from R (reverse) position to D (drive) position (at vehicle speed of 15 km/h or lower).
- The front parking assist warning ON/OFF switch is in ON (indicator off) position. (at vehicle speed of 15 km/h or lower)
However, it will remain off after the vehicle speed exceeds 15 km/h.

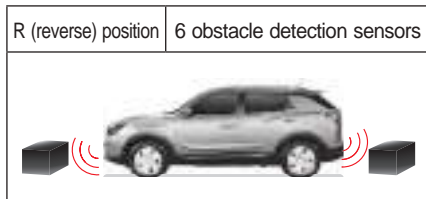

When the gear shift lever is placed in the R (reverse) position, 2 front obstacle detection sensors and 4 rear obstacle detection sensors are activated at the same time.

Notice
<ul style="list-style-type: none"> • The front obstacle detection sensor always works while reversing with the front obstacle detection alarm ON/OFF switch pressed (OFF indicator lit). • The front obstacle detection sensor always works at low speed. An alarm may sound intermittently in the event of rain and this is not a malfunction but normal operation.

Indication on the display of the instrument cluster

When an obstacle is detected, the relevant edge indicating the detection distance and direction blinks.



Display of the instrument cluster	
D (driving) position	R (reverse) position

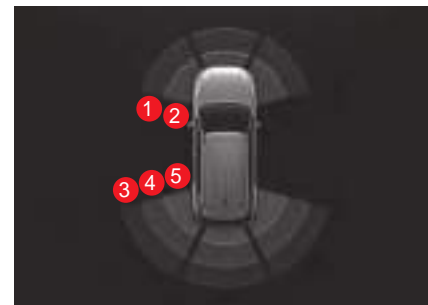

When no obstacle is detected



The range of front and rear sensors is displayed and blinks (no warning buzzer)

If an obstacle is detected from 40 cm at the front left side or the front right side



Line No. ① at the front left side is deleted and Line No. ② blinks (Warning buzzer sounds)

If an obstacle is detected from 80 cm at the rear left side, front side or right side



Line No. ③ at the rear right side is deleted and Line No. ④ blinks (Warning buzzer sounds)

Warning buzzer interval

The warning buzzer sounds as follows depending on the distance from the obstacle.

Front obstacle detection sensor (level 2 warning buzzer)

Warning buzzer interval	Distance from the obstacle	
	Center	Side
No warning buzzer	100 cm	60 cm
① 0.15 second	50 cm ~ 100 cm	40 cm ~ 60 cm
② Continuous	25 cm ~ 50 cm	25 cm ~ 40 cm

Rear obstacle detection sensor (Level 3 warning buzzer)

Warning buzzer interval	Distance from the obstacle	
	Center	Side
③ 0.3 second	80 cm ~ 120 cm	-
④ 0.15 second	50 cm ~ 80 cm	
⑤ Continuous	25 cm ~ 50 cm	

Sensor and relevant system malfunction

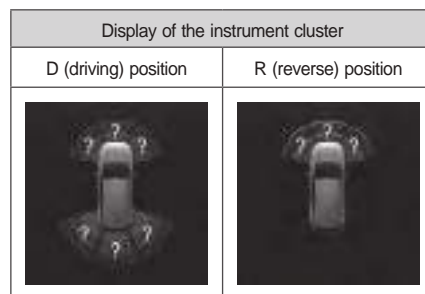

When the obstacle detection sensor is abnormal, “?” is displayed for the relevant sensor. If this message is display on the display of the instrument cluster, have your vehicle checked and serviced at a nearby KG Mobility Authorized Service Center.

! Caution

- If the distance between the sensor and the obstacle is 25 cm or less, the warning buzzer does not sound. However, if the obstacle is recognized clearly, the warning buzzer may sound.
- When the warning buzzer sounds, the distance from the obstacle may be different from the actual distance by approximately ± 10 cm.
- Do not rely too much on the parking assist system and reverse the vehicle while checking the rear side.
- If an abnormal warning buzzer whose duration is different from a warning buzzer that occurs due to the detection of an obstacle or a long warning buzzer for 3 seconds occur when the gear shift lever is placed in the R (reverse) position, the obstacle detection system or the detection sensor is abnormal. Have your vehicle checked.

If the system does not operate or malfunctions

If there is an object that cannot be detected by the sensor

- A thin object such as steel wire, rope or chain
- An object such as cotton, sponge, fiber or snow that absorbs sound waves
- An object that is located lower than the bumper (example : drainage or puddle)

The sensor cannot detect

- when the sensor is frozen (the normal function is restored after thawed.)
- When sensor is clogged by foreign materials such as snow, mud or water drops (the normal function is restored after removed)

When the sensor detection range becomes narrower

- The sensor is partially covered with snow or mud so that the signal detection area becomes narrower (the normal function is restored after removal)
- When the temperature near the sensor is extremely high or low

Cases that may cause malfunction although it is not a system failure

- Driving the vehicle on bumpy roads, gravel roads, hillside road, or grass
- When the height of the bumper is lowered due to heavy load
- When other ultrasound waves are received (metallic sound, air brake sound of a large vehicle, etc)
- When a high-power radio set is used
- When there is a heavy rain
- When an accessory is attached to or near the area where the sensor is installed

When towing a trailer

- The sensor may detect the trailer, sounding the warning buzzer continuously.

Cautions regarding the front/rear obstacle detection system



Caution

- When parking or reversing the vehicle, check if there is any person, animal or especially a child around. If you cannot check it properly, be sure to get out of the vehicle and check.
- The parking assist system is only a system for the user's convenience and this system does not guarantee safety. The driver should pay attention to all possible conditions.
- When you strongly press or apply an impact to the sensor part on the bumper or strong water pressure is applied during car wash, the sensor may be damaged.
- When the system is normal and the gear shift lever is placed in the R (reverse) position with the START/STOP switch in the ON status, a beep sounds once briefly.
- If an abnormal warning buzzer whose duration is different from a warning buzzer that occurs due to the detection of an obstacle or a long warning buzzer for 3 seconds occur when the gear shift lever is placed in the R (reverse) position, the obstacle detection system or the detection sensor is abnormal. Have your vehicle checked.

- In the parking space shown in the figure below, the upper portion of the vehicle may collide before the detection sensor at the bottom operates. Park the vehicle while checking through the outside rearview mirror or turning your head directly.



Rear camera system

The rear camera system is an auxiliary safety system that allows the driver to view the situation behind the vehicle through the rear camera using the monitor when the gear shift lever is placed in the R (reverse) position.

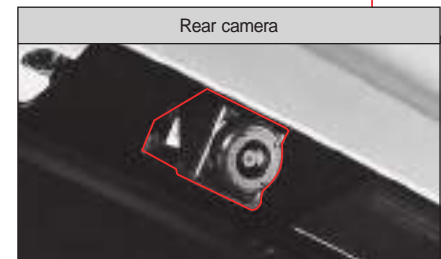
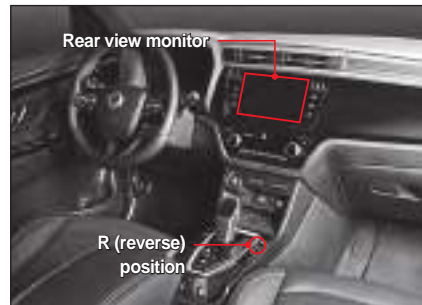



Caution

- The rear camera uses a wide-angle lens to secure a wide view, so the actual distance is different from what you see through the monitor. Be sure to check the rear, left and right view directly.
- The screen shown on the monitor is a part of, not the whole background view of the vehicle.
- Clean the rear camera lens frequently using a camera lens cleaner to prevent it from being contaminated.



Warning

- The rear camera screen does not work during software update. Always stop the vehicle to update the software and do not drive the vehicle until the update is completed.
- Be careful when reversing since the rear obstacle may be hidden by the warning messages and parking guide lines if the rear camera system is activated.

Double parking (2-row parking)

Vehicles With EPB

Since double parking (2-row parking) is required due to insufficient parking space, operate as follows.

- 1 With the START/STOP switch in the ON status or while the vehicle is running, release the Electronic Parking Brake (EPB).



Notice

- If the AUTO HOLD function is activated, the EPB is activated automatically. Be sure to deactivate the function by pressing the AUTO HOLD switch before carrying out the process.

- 2 With the transmission in P (Park) position, turn off the ignition.
- 3 Turn the ignition on without depressing the brake pedal.
- 4 Depress the brake pedal and shift the transmission into N (Neutral) position (EPB released).
- 5 Turn the ignition off without depressing the brake pedal (transmission remains in N position and EPB remains released).



Warning

- Be sure to carry out double parking (2-row parking) on completely flat ground and take a separate measure such as placing a chock on the wheels. Failure to do so may cause the vehicle to move, that is very dangerous.
- When using an automatic car washer, etc. in double parking mode, i.e. with the gear selector lever in the N (neutral) position, never press the P (park) button. If you drive the vehicle into a car wash with the gear selector lever in the P (parking) position, problems may occur in your vehicle, automatic car washer and etc.

5. Emergency Measures in the Event of Emergency

You can check useful information and emergency measures for various emergency situations you can face while driving.

Information regarding the warning triangle and OVM tools, the correct procedure in case of a dead battery, flat tire, and towing a vehicle is provided.

An explanation is also provided for how to respond to a fire, heavy snow, vehicle trouble, and an accident safely.

OVM (Owner Vehicle Maintenance) tools

OVM tools

The OVM tools are apparatuses or tools stored in the vehicle in preparation for a failure or an emergency situation that can occur while driving the vehicle.



- 1 Sealant (Emergency sealing compound in case of a flat tire)
- 2 Compressor (managing the tire pressure and injecting sealant in case of a flat tire)
- 3 Spanner
- 4 Screwdriver (+ and -)
- 5 Vehicle towing hook
- 6 Tool roll pouch

Location where the OVM tools are stored

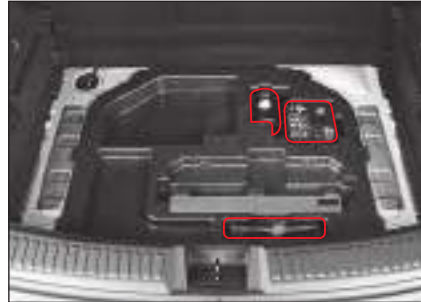

The OVM tools are stored in the storage box at the rear left side of the luggage compartment. Take out and use the OVM tools any time when necessary.

When Low Voltage (12 V) Battery Discharged (Emergency Start-up)

If the vehicle cannot be started due to depletion of the low battery, you can start the vehicle by connecting a battery of the same standard and capacity from another vehicle or an auxiliary battery to your battery using the jump cable.

Starting the vehicle using the jump cable

Warning

- Emergency start-up with jump cable is an extremely dangerous task that can damage the electrical system or cause injuries from battery explosions. Ask an expert for help and follow instructions below.



- 1 Make sure the 12 V battery with the same specification is correct.
- 2 Switch off all electrical accessories of the depleted vehicle.
- 3 Connect the jump cable in the following order.
 - + terminal (1) of the depleted battery
 - + terminal of the battery in another vehicle or an auxiliary battery that provides power supply
 - - terminal of the battery in another vehicle or an auxiliary battery that provides power supply
 - Vehicle body of the depleted vehicle (2) (a location far from the battery)
- 4 If the battery of another vehicle is used, start the engine of the relevant vehicle and idle the engine for several minutes.
- 5 Start the engine of the depleted vehicle.
- 6 When the vehicle is started, separate the jump cable in the following order.
 - Jump cable connected to the minus (-) terminal
 - Jump cable connected to the positive (+) terminal



Warning

- Follow the procedure to start the vehicle using the jump cable explained in this owner's manual. Failure to do so may cause an injury or damage the vehicle due to a battery explosion.
- If the battery is frozen, do not attempt to start the vehicle using the jump cable. Doing so may lead the battery to burst or explode, causing serious injury.
- Be sure to wear insulated gloves for starting the vehicle using the jump cable to prevent an electric shock.
- Make sure that two vehicles do not come into contact with each other. Failure to do so may result in ground connection status, causing an electric shock and a vehicle failure.
- Be sure to use the jump cable of the specified standard and a battery of the same standard and capacity. Failure to do so may cause a spark when the jump cables are connected and gas generated from the battery may explode.
- When using the battery of another vehicle, connect the jump cable with the motor of the other vehicle turned off for safety.



Warning

- When connecting the jump cables, make sure that the positive (+) and negative (-) cables do not come into contact with each other. Otherwise, an electric spark may occur, resulting in the explosion of the battery.
- Make sure that the jump cables are securely fixed to each terminal. Failure to do so may cause disconnection due to an instantaneous vibration when the vehicle is started. If the jump cable is separated and comes into contact with the vehicle body, an electric shock may be applied to the vehicle, damaging electric and electronic components.
- The battery fluid is very acidic, so if it comes into contact with your eyes or on your skin, take off the clothes that are stained with the battery fluid immediately, rinse the contacted area with clean water continuously and contact your doctor. While being transported to a hospital, gently wipe the contacted area with a water-wet soft cloth or sponge continuously.



Caution

- Make sure when starting the vehicle that the jump cable is not wound around the fan in the motor room.
- After starting the vehicle using the jump cable, do not turn off the vehicle for a certain period of time to allow the depleted battery to be recharged. Otherwise, you may not be able to start the vehicle again according to the charging status of the battery.
- If the cause of the depleted battery is not clear, have your vehicle checked at a KG Mobility Authorized Service Center.

When a tire is flat



If a tire becomes flat while driving, do not panic and take action according to the following order.

- 1 Turn on the hazard warning lamp indicator.
- 2 Stop the vehicle at a safe place.
For such purpose, hold the steering wheel firmly, take your foot off the accelerator pedal, decelerate the vehicle slowly and depress the brake pedal slightly to stop the vehicle safely.
- 3 Place the gear shift lever in the P (parking) position and apply the parking brake.
- 4 Place a chock in front of and at the back of the tires located in the diagonal direction of the flat tire.

- 5 Be sure to place the warning triangle on a road or an expressway where other vehicles are driving.
The position that is easily identified by a driver in an approaching vehicle while maintaining a safe distance (100 m during daytime, 200 m in the rear during night time) is an appropriate place to place the warning triangle.
- 6 If there are other occupants besides the driver, evacuate such occupants to a safe place.
- 7 Judge if the flat tire can be repaired using the service kit for tire repair (stored in the storage box of the luggage compartment) and take the necessary action accordingly.

Warning

- If a tire becomes flat while driving, do not steer the vehicle or depress the brake suddenly. Doing so may cause the vehicle to lose its stability, leading to an accident.
- Do not drive the vehicle for even a short distance with a flat tire. Doing so may damage the wheels and disable normal driving, leading to a dangerous situation.
- Turn on the hazard warning lamp indicator, move the vehicle to the shoulder of the road or a safe location and place the warning triangle in a place easily identified by a driver in an approaching vehicle.
- If possible, park the vehicle on a flat, solid, and non-slippery road surface and repair the tire with no occupants in the vehicle.

Notice

- If you are not good at repairing a flat tire, request a KG Mobility Authorized Service Center or your auto insurance company for help.

Repairing a flat tire/inflating a tire using the service kit for tire repair

Components of the service kit for tire repair

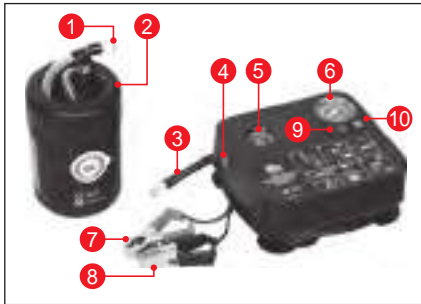

- 1 Sealant filler hose
- 2 Sealant
- 3 Air injection hose
- 4 Sealant removal button
- 5 Sealant mounting
- 6 Pressure gauge
- 7 Positive (+) cable
- 8 Negative (-) cable
- 9 Power switch
- 10 Deflating button

Storage location of the service kit

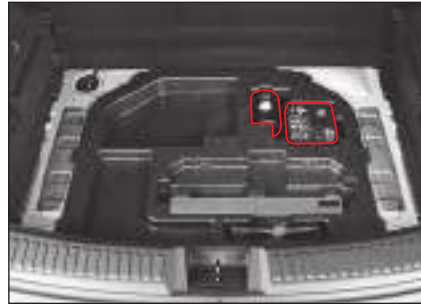

The service kit for tire repair is stored in the storage box at the rear left side of the luggage compartment with the OVM tools.

Confirming whether it is possible to repair the flat tire with the service kit or not

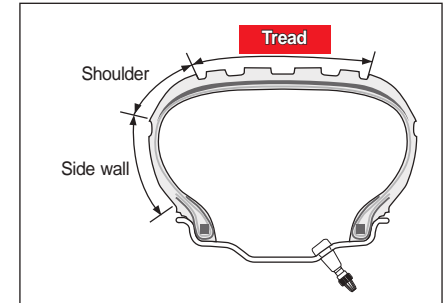

When a tire is flat, check the position of the hole first and use the service kit after judging whether it can be repaired using the service kit or not.

- If the size of the hole on the tread of the tire is less than 6 mm, it can be repaired using the service kit.

Warning

- Do not repair the tire using the service kit if the tire shoulder or the side wall is torn or there is a sign of cracks or damage. In such case, have the tire checked and serviced at a KG Mobility Authorized Service Center or contact your car insurance company.

Operating principle of the service kit

When the vehicle is driven after the sealant is injected using the compressor, the sealant is spread on the inner surface of the tire, filling up the hole and enabling temporary driving.

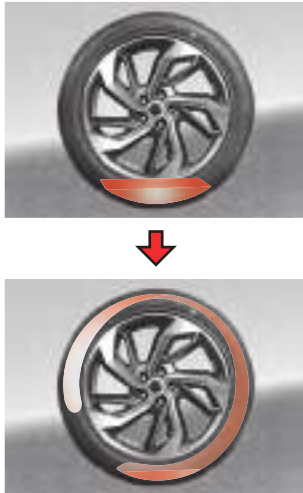

Repairing a flat tire

When a tire is flat, it can be repaired in the following method using the service kit.

- 1 Take out the tire repair service kit from the bottom of the luggage compartment board.



- 2 Remove the speed limit sticker on the side of the sealant container and attach it to the steering wheel.



Caution

- The speed limit sticker alerts the driver that the tire has been repaired using the service kit and the speed should be limited. Do not drive the vehicle at a speed faster than 110 km/h at any time.

- 3 Take out the sealant filler hose at the top of the sealant container.



! Caution

- Check the expiration date of the sealant. The expiration date is marked on top of the sealant. Replace expired sealant with a new one since the sealing performance of the expired sealant may be degraded.
- Be sure to read the cautions on the container before using the sealant.

Notice

- Before using the sealant, shake the container well to mix the contents.

- 4 Fix the sealant container onto the compressor body completely.



- 5 Remove the air valve cap of the flat tire.
- 6 Connect the sealant filler hose which you took out at the sealant container to the air valve of the flat tire firmly.

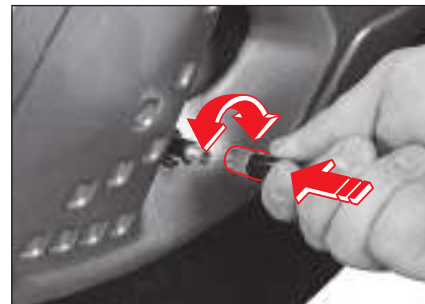

! Caution

- The power switch of the service kit should be in the OFF position.

- 7 Take out the + (red) / - (black) cables at the bottom of the compressor.

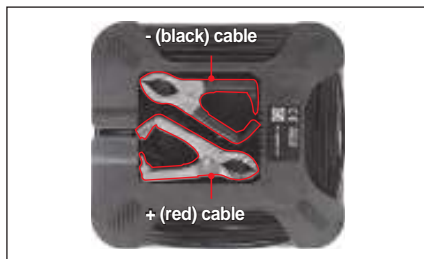

- 8 Connect the + (red) (1) cable of the service kit to the vehicle battery and then connect the - (black) (2) cable.



Warning

- Use caution when connecting the cables. Sparks may occur.

Caution

- Connecting the positive (+) and negative (-) terminals of the battery in reverse may result in damage to the battery and the tire service kit. Be sure to connect the cables in the correct order.
- Be sure to start with removing the negative (-) terminal (black cable) when disconnecting the cables.

- 9 Start the vehicle.

Warning

- Be sure to repair a tire in a well-ventilated area.

- 10 Press the power switch of the service kit to activate the compressor.

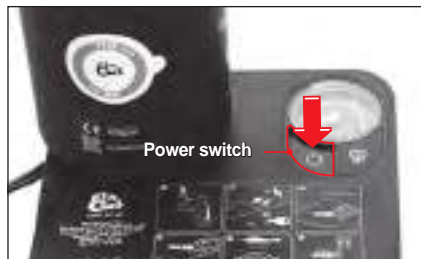

Caution

- Do not operate the compressor for more than 10 minutes. Doing so may overheat the compressor, leading to a malfunction.

- 11 Wait until the pressure reaches the prescribed pressure (36 psi, 2.48 bar) while checking the pressure gauge of the service kit.

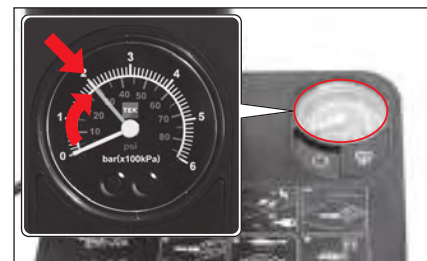

Warning

- If the specified tire pressure is not reached within 8 minutes (however, current tire pressure has reached at least 26 psi), re-inflate the tire as described below:
 1. Stop using the service kit and remove the sealant from the compressor.
 2. Place the service kit back in place (bottom of the luggage compartment board).
 3. Drive the vehicle at low speed for about 10 m so that the sealant is applied on the inner surface of the tire evenly.
 4. Fit the air injection hose at the compressor to the flat tire.
 5. Connect the power cable at the bottom of the compressor to the vehicle battery.
 6. Start the vehicle to operate the compressor.
 7. Operate the compressor until the tire pressure reaches to the specified value (36 psi, 2.48 bar).

If the tire is overinflated, press the air pressure release button to adjust the tire pressure.



- 12 When the prescribed pressure is reached, turn off the service kit.

Caution

- If the tire pressure does not go above 26psi after operating the compressor for more than 10 minutes, the tire cannot be repaired using the service kit. Request an emergency rescue service or vehicle towing.

- 13 Disconnect the air hose from the tire.
- 14 Install the air valve cap on the tire.
- 15 Turn off the vehicle.
- 16 Remove the sealant container and the air hose from the service kit and place the service kit back to its original position (bottom of luggage compartment board).
- 17 Drive the vehicle immediately for approximately 10 km to allow the sealant to be spread on the inner surface of the tire evenly.
- 18 Stop the vehicle at a safe place and measure the tire pressure with the service kit.



Warning

- Use the service kit only when a small hole (approximately 6 mm or less) has occurred on the tread of the tire.
- Do not use the service kit if the tire shoulder or side wall is torn or the hole is too large. In such case, have your vehicle towed or serviced at a KG Mobility Authorized Service Center.
- When a tire repaired using the service kit is fixed, drive the vehicle at a speed less than 110 km/h.
- The service kit should be used only for temporary repair. The maximum distance that can be traveled with a tire repaired by injecting sealant is approximately 200 km.
- If a vibration occurs or the steering is unstable and a noise occurs while driving, stop driving the vehicle immediately. In such case, have your vehicle serviced at a KG Mobility Authorized Service Center.



Caution

- Remove the sealant container carefully to prevent the sealant from coming into contact with your skin. If sealant comes into contact with your skin, wash it with soapy water.
- The sealant container cannot be used after it is used once. Just in case, purchase and replace with new sealant.
- Do not discard the used sealant container anywhere. Return it to a KG Mobility Authorized Service Center.
- Do not use an unauthorized sealant which is not KG Mobility genuine sealant. Doing so may damage the sensor of the TPMS.
- Replace the tire repaired using the sealant with a new one at a KG Mobility Authorized Service Center as soon as possible and have the TPMS checked for abnormality.
☞ Refer to "Tire pressure monitoring system (TPMS)" (p.2-29)

Checking the tire pressure after repairing a flat tire

The pressure of the tire repaired using the service kit should be checked as follows after driving for approximately 10 km.

- 1 Take out the tire repair service kit from the bottom of the luggage compartment board.
- 2 Take out the air hose from the service kit.
- 3 Remove the air valve cap of the tire.
- 4 Connect the air hose of the service kit to the air valve on the tire firmly.
- 5 Check the tire pressure from the pressure gauge of the service kit.

If the tire pressure is higher or lower than the prescribed pressure (36 psi, 2.48 bar), adjust it to the prescribed pressure using the air valve of the tire.



Warning

- If the tire pressure is not maintained at the prescribed pressure (36 psi, 2.48 bar), stop driving the vehicle immediately and request a KG Mobility authorized service for help.

Inflating a tire

When the tire pressure is insufficient, you can inflate the tire to the prescribed pressure with the following method using the service kit.

- 1 Take out the tire repair service kit from the bottom of the luggage compartment board.
- 2 Take out the air hose (1) and the power cable (2) from the service kit.

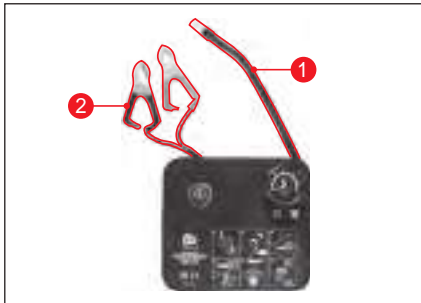

- 3 Remove the air valve cap of the tire you wish to inflate.
- 4 Connect the air hose of the service kit to the air valve on the tire firmly.

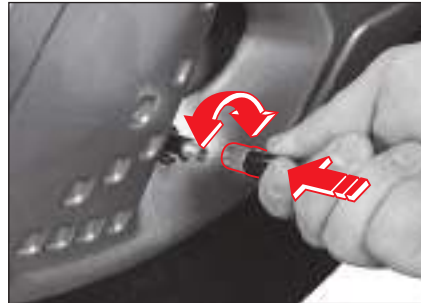

Caution

- The power switch of the service kit should be in the OFF position.

- 5 Take out the + (red) / - (black) cables at the bottom of the compressor.

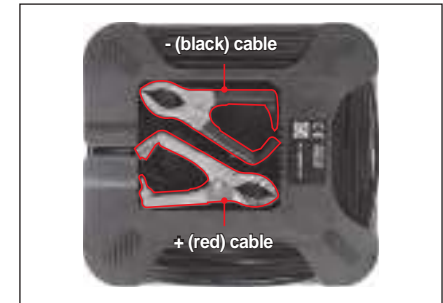

- 6 Connect the + (red) (1) cable of the service kit to the vehicle battery and then connect the - (black) (2) cable.

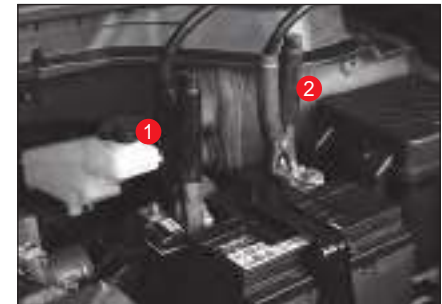

7 Start the vehicle.

Warning

- Be sure to repair a tire in a well-ventilated area.

8 Press the power switch (1) of the service kit to activate the compressor.

9 Wait until the pressure reaches the prescribed pressure (36 psi, 2.48 bar) while checking the pressure gauge (2) of the service kit.



If the tire is overinflated, press the air pressure release button to adjust the tire pressure.



10 When the prescribed pressure is reached, press the power switch (1) of the service kit to turn it off.

Caution

- Do not operate the compressor for more than 10 minutes. Doing so may overheat the compressor, leading to a malfunction.

- 11 Turn off the vehicle.
- 12 Disconnect the air hose from the tire.
- 13 Install the air valve cap on the tire.
- 14 Place the service kit back to its original position (storage box at the rear left side of the luggage compartment).

When you need to have your vehicle towed

Towing a disabled vehicle

- Flat towing

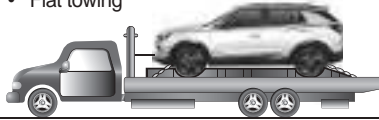

- Towing with front wheels on ground

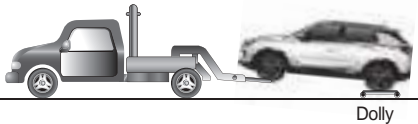

Dolly

- Towing with rear wheels on ground

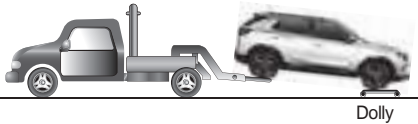

Dolly

Towing with tow truck

The best towing method is to lift the entire vehicle onto the flatbed so that all wheels are off the ground. If it is impossible, put the front or rear wheels on the jig and tow the vehicle using a dolly, with other wheels off the ground.

Warning

- If your vehicle should be towed due to wheel slips in mud or sand, you can use the towing hooks in your vehicle. However, if the load to hooks is too heavy, the towing hook, rope or chain could be broken, resulting in serious personal injury and vehicle damage.
- To prevent damage to your vehicle, proper lifting and towing procedures are necessary. When you need a towing service, contact KG Mobility Dealer or KG Mobility Authorized Service Center.

For 2WD vehicles

It is not allowed to use a tow truck or keep the rear wheels from moving with the parking brake released for towing, as shown in the following figure.

Do not tow the vehicle with the rear wheels on the ground.

Caution

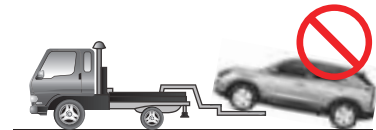

- Do not tow with the sling-type equipment or the bumper and lower parts can be damaged.
- Be careful not to damage the bumper and lower parts during towing.

When a tow truck is unavailable (in case of emergency)

If your vehicle needs to be towed when a tow truck is unavailable, you can have your vehicle towed by installing the towing hook to a towing vehicle and the vehicle to be towed and connecting the two vehicles with the towing rope (sold separately).

Installing the towing hook

- 1 Take out the towing hooks from the OVM tools stored in the storage box at the rear left side of the luggage compartment.
- 2 Press the bottom side (1) of the hole cover located in the front bumper of the vehicle to be towed and the rear bumper of the towing vehicle each to remove the cover.
- 3 Insert the towing hook into each hole and fasten it firmly.

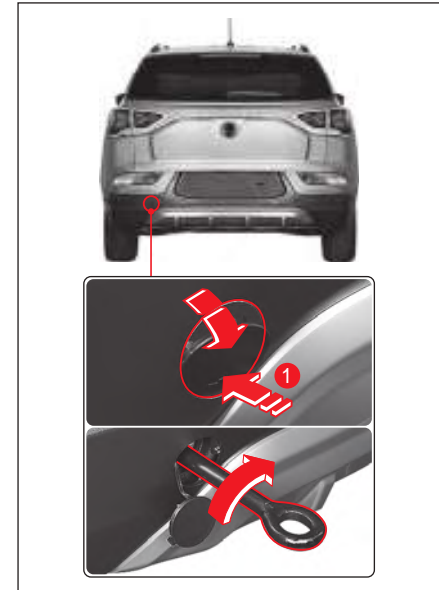
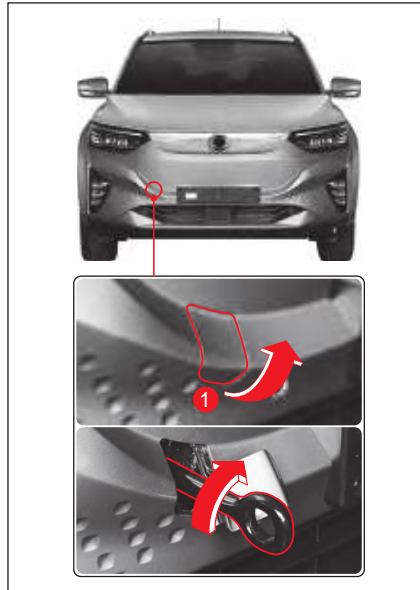

Using a towing rope

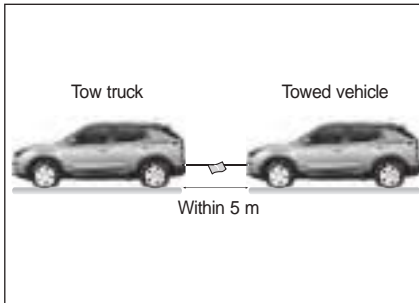

- 1 Connect the towing rope to the towing hook of the towing vehicle and the vehicle to be towed securely.
- 2 Tie a white cloth in the middle of the rope so that the towing rope is clearly visible.
- 3 Release the parking brake of the vehicle to be towed and place the SBW (shift by wire) in the N (neutral) position.
- 4 If the vehicle of the vehicle to be towed is turned off, place the START/STOP switch in the ON position.
- 5 Turn on the hazard warning lamp of both the towing vehicle and the vehicle to be towed.

- 6 Start the vehicle of the towing vehicle and tow the vehicle to be towed.

At this time, the length of the towing rope should be less than 5 m and the total length of the towing vehicle and the vehicle to be towed should not exceed 25 m.

Tow the vehicle at a speed of 5 km/h or less.



Warning

- Use the towing hook only for towing a vehicle for a short distance temporarily or in an emergency situation. Avoid using it for towing all the time.
- If you want to tow the vehicle using the towing hook, make sure that the force is applied in the front, rear and horizontal direction. Do not drive off suddenly or recklessly since it can apply excessive load to the towing hook. Doing so may damage the towing rope or chain, leading to vehicle damage or a serious injury.



Caution

- Avoid impractical towing and towing a vehicle which is heavier than the towing vehicle.
- If there are many steep downhills or slopes in the towing path, do not attempt to tow the vehicle using the towing hook.
- The brake performance is significantly lowered while the vehicle is not running. Therefore, depress the brake pedal stronger than usual when towing the vehicle using the towing hook.
- Tow the vehicle while operating the turn signal and the hazard warning lamp along with the towing vehicle's signals.

Trailer towing

Your vehicle is designed primarily as a passenger vehicle therefore handling, braking, durability and economy will be affected by towing a trailer.

Your safety and satisfaction depend upon proper use of correct equipment. Also, you should avoid overloading and other abusive use.

The maximum loaded trailer weight you can pull with your vehicle depends on your intended use and what special equipment has been installed on it. Before attempting any towing, ensure that the correct equipment is fitted to your vehicle.

Your KG Mobility Dealer will help supply and install towing equipment to suit your requirement.

Trailer loading

To load your trailer properly, you must know how to measure gross trailer weight and trailer ball weight. Gross trailer weight is the weight of the trailer plus all cargo in it.

You can measure gross trailer weight by putting the fully loaded trailer on a vehicle scale.

Trailer ball weight is the downward force exerted on the hitch by the trailer coupler at its normal towing height. This weight can be measured using a bathroom scale.

The weight of your loaded trailer (gross trailer weight) should never exceed the specified values.

The permissible trailer loads are valid for several gradients from 6.8% to 12.6% according to vehicle power applied.

When the trailer has been coupled, the permissible rear axle load for the fully loaded towing vehicle (including occupants) must not be exceeded.

Maximum Load Limits

(unit: kg)

Type	Maximum Trailer	Trailer coupling weight	
		Maximum permissible static vertical load on the coupling device	Maximum trailer hitch
with brake	1,500	60	25
without brake	500		

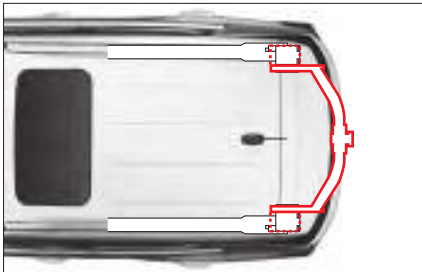
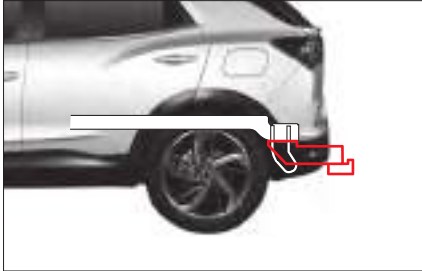

If you want to pull a trailer

Important points:

- You have to consider a sway control. You can check the sway control to hitch dealer.
- If the total driving distance of your new vehicle is under 800 km (500 miles), do not tow a trailer. For the first 800 km (500 miles) that you tow a trailer, do not drive over 80 km/h (50 mph) and do not start off your vehicle at full throttle. Otherwise, your other parts could be damaged due to heavier loads.
- Always drive your vehicle at a moderate speed (less than 80 km/h).
- You have to consider the weight of trailer.
- The permissible trailer ball weight varies according to the cargo weight on the deck.
- It has to be limited to the number of passengers by 5 people including a driver.

Weight of trailer

To keep the vehicle and trailer safely, you must consider many factors except the maximum load limit.

The vehicle and trailer's safety depends on how you use your trailer. Vehicle speed, altitude, load, outside temperature and frequency of using trailer are all very important. Any special equipment on your vehicle also affects on your vehicle.

Weight of trailer tongue

The tongue load of a trailer is also considered very carefully because it affects the gross vehicle weight (GVW) of your vehicle. This weight includes the curb weight of vehicle, any luggage in trailer, and the passengers in vehicle. In addition to that, you must add the trailer tongue load to the GVW because your vehicle will carry all the weight.

The trailer tongue should weigh a maximum of 4% of total loaded trailer weight. To check the weights are proper, you must weigh the trailer and the tongue separately after loading. If the weights are not proper, unload some items from the trailer.

Caution

- **Never load a trailer with more weight in the rear side than in the front side. (Recommendation - Front: approx. 60%, Rear: approx. 40%)**
- **Never exceed the maximum load limits of trailer or trailer towing equipment. Improper loading may result in damage to your vehicle. It may occur the personal injury. Before driving, check the weight and loading at a commercial scale or highway patrol office equipped with scales.**
- **An improperly loaded trailer may cause the loss of vehicle control.**
- **When towing the trailer, turn the Idle Stop & Go (ISG) system off.**

Trailer brakes

If the trailer brakes are used, you should follow all instructions provided by the manufacturer. Never modify the brake system of your vehicle.

Trailer lights

Make sure your trailer is equipped with lights which meet country and local requirements.

Always check for the proper operation of all trailer lights before you start to tow.

Tires

When towing trailers, be sure your tires are properly inflated to the inflation pressure.

Safety chains

Always attach safety chains between your vehicle and the trailer. Cross the safety chains under the tongue of the trailer so that the tongue will not drop to the road if it becomes separated from the hitch. Follow the manufacturer's recommendation for attaching safety chains. Always leave just enough slack to permit full turning. Never allow safety chains to drag on the road.

Brake fluid

Change the brake fluid every 15,000 km (9,000 miles) under the following conditions.

- Towing a trailer frequently.
- Driving in hilly or mountainous terrain.

Automatic transmission fluid

More frequent maintenance is required if your vehicle tows trailer frequently.

Towing tips

When towing a trailer, your vehicle will handle differently compared with normal driving condition.

- For safety, observe the following precautions:
- Practice turning, stopping, and reversing before you begin towing in traffic. Do not tow in traffic until you are confident that you can handle the vehicle and trailer safely.
- Before driving, make sure that the lighting system of the trailer works properly.
- Do not drive faster than 80 km/h.
- Make sure that you have enough room when cornering and avoid sudden maneuvers.
- Avoid abrupt starts, acceleration or stops.
- Avoid sharp turns or lane changes.
- Always have someone guide you when reversing.
- Allow adequate stopping distance. Stopping distance is increased when you tow a trailer.
- Avoid holding the brake pedal down too long or too frequently, which will cause the brakes to overheat and result in reduced brake efficiency.
- Always block the wheels on both vehicle and trailer when parking. Apply the parking brake firmly.
- Parking on a steep slope is not recommended. You really should not park your vehicle, with a trailer attached, on a hill. If something goes wrong, such as the trailer/caravan hitch becoming disengaged, people can be injured and both the vehicle and trailer can be damaged.
- If someone removing the blocks stands directly behind the trailer, he could be injured. If your brakes or the hitch slipped, the trailer could roll backward. Make sure anyone removing blocks from your wheels stands to one side.
- Take note of trailer manufacturer's instructions.

Driving on hill

You start down a long or steep downgrade. If you don't shift down, you might have to use your brakes so much that they would get hot and no longer work well.

Parking on hills

You really should not park your vehicle, with a trailer attached, on a hill. If something goes wrong, your rig could start to move. People can be injured, and both your vehicle and the trailer can be damaged.

But if you ever have to park your rig on a hill, here's how to do it:

- 1 Apply your regular brakes, but don't shift into PARK (P).
- 2 Have someone place chocks under the trailer wheels.
- 3 When the wheel chocks are in place release the regular brakes until the chocks absorb the load.
- 4 Reapply the regular brakes. Then apply your parking brake, and then shift to PARK (P).
- 5 Release the regular brakes.

When you are ready to leave after parking on a hill

- 1 Apply your regular brakes and hold the pedal down while you:
 - Start your vehicle
 - SBW into a gear and
 - Release the parking brake.
- 2 Let up on the brake pedal.
- 3 Drive slowly until the trailer is clear of the chocks.
- 4 Stop and have someone pick up and store the chocks.

Maintenance when towing trailer

Your vehicle will need service more often when you're towing a trailer. See the maintenance Schedule for more on this. Things that are especially important in trailer operation are brake pads & discs. Each of these is covered in this manual and the index will help you find them quickly. If you want to tow a trailer, it's a good idea to review these sections before you start your trip. Check periodically to see that all hitch nuts and bolts are tight.

When the vehicle has stopped due to a failure

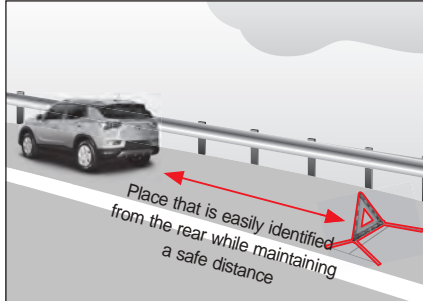

If the vehicle malfunctions and has stopped while driving, do not panic and take an action according to the following order.

- 1 Turn on the hazard warning lamp of the vehicle.
- 2 Move your vehicle to the right shoulder of the road or a safe location.
- 3 Place a warning triangle (if it is available).
The position that is easily identified by a driver in an approaching vehicle while maintaining a safe distance (100 m during daytime, 200 m in the rear during night time) is an appropriate area to place the warning triangle.
Place a road flare additionally at night.
- 4 Evacuate all occupants to a safe place.
- 5 Request an emergency rescue service or vehicle towing.

In the event of an accident

If an accident has occurred while driving, do not panic and take an action according to the following order.

- 1 Turn on the hazard warning lamp of the vehicle.
- 2 Move your vehicle to the right shoulder of the road or a safe location.
- 3 Place a warning triangle (if it is available).
The position that is easily identified by a driver in an approaching vehicle while maintaining a safe distance (100 m during daytime, 200 m in the rear during night time) is an appropriate area to place the warning triangle.
Place a road flare additionally at night.
- 4 Evacuate all occupants to a safe place.
- 5 If anyone is injured, give aid and call an ambulance.
- 6 Contact the nearest police station and when a police officer arrives, follow his/her instructions.
- 7 Even in case of a minor accident, be sure to visit a hospital and see the doctor.

Tips when an accident or a malfunction occurs on the expressway

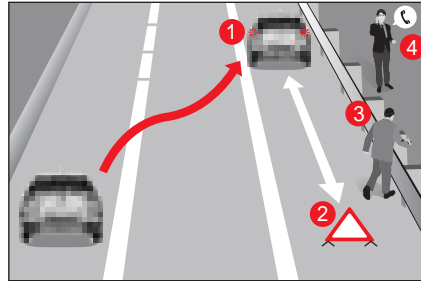

When you stop the vehicle on the expressway due to an accident or a malfunction, take an action according to the following order in order to prevent a secondary accident.

- 1 Turn on the hazard warning lamp promptly and move the vehicle to the shoulder of the road (1).
- 2 If a warning triangle or a road flare is available: Place a warning triangle on the rear side of the vehicle (2). (Place a road flare additionally at night)
- 3 The driver and any occupants should be evacuated to a safe area such as behind the guardrail (3).
- 4 If you need help, contact the police, fire department, or highway department.

Warning

- In the event of a vehicle accident, move the vehicle to a safe place and cut off power by turning off the vehicle and disconnecting the terminals of the auxiliary battery (12 V) to prevent high voltage electrical leakage.
- Do not touch the wires if there are exposed wires when viewed from inside or outside the vehicle. In addition, do not touch high voltage wires (orange) and connectors and all electrical components and devices. Failure to do so may result in electrical shock.
- In the event of a vehicle accident, the drive (high voltage) battery may be damaged, resulting in leakage of gases and electrolytes harmful to the human body. Be careful not to let leaked liquids touch your skin. If combustible and toxic gas leaks are suspected, open windows to ventilate and evacuate to a safe place. If a leaked liquid enters the eye or comes into contact with the skin, immediately flush the area with running or salt water and consult a doctor.
- If your vehicle is flooded, turn off the ignition immediately, evacuate to a safe place, and contact emergency agencies such as fire stations and KG Mobility dealer or KG Mobility Authorized Service Center for assistance.

In the event of a fire

When a fire has occurred in the vehicle, do not panic and take an action according to the following order.

- 1 Turn on the hazard warning lamp of the vehicle.
- 2 Stop the vehicle at a safe place immediately and stop the vehicle.
- 3 Extinguish the fire using an extinguisher.
- 4 If you cannot extinguish the fire, report it to a police station or a fire station.
At this time, do not approach the vehicle and maintain a safe distance with the vehicle.

Warning

- When a vehicle accident occurs, the fuel may leak, causing a fire. Stop the vehicle immediately and keep any inflammables away from the vehicle.



Warning

- In the event of a vehicle fire, extinguish the fire using a powder fire extinguisher dedicated to the electric fire. If an electrical fire extinguisher is not available, use sufficient water to extinguish the fire. Using a small amount of water or an improper fire extinguisher may result in injury from electrical shock. If the fire cannot be extinguished quickly, the drive (high voltage) battery may heat up and explode, so evacuate to a safe place and keep people away from it. Contact emergency agencies, such as fire station, to inform them of the electric vehicle fire and take action.
- For small fires, use an electrical fire extinguisher (ABC and BC fire extinguishers) to extinguish the fire. If early fire suppression is not possible, evacuate to a safe place and keep people away from the vehicle. Make an emergency phone call to notify the electric vehicle of a fire and receive appropriate guidance on the fire.
- If the fire has spread to a high voltage battery underneath the vehicle, a large amount of water must be continuously supplied for a long period of time to completely extinguish the fire. If a small amount of water or an inappropriate fire extinguisher is used, it is difficult to extinguish the fire and may result in an electric shock.

Placing an extinguisher in the vehicle

Place an extinguisher in the vehicle since it is needed for early fire extinguishing when a fire occurs.

How to use the extinguisher

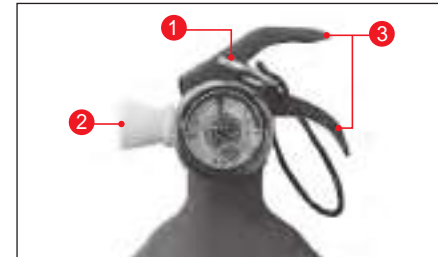

- 1 Remove the safety pin (1) from the extinguisher with the wind at your back.
- 2 Face the extinguisher nozzle (2) towards the place where the fire occurs.
- 3 Hold the handle (3) and spray to the place where the fire occurs, using a sweeping motion.

Checking and maintaining the extinguisher

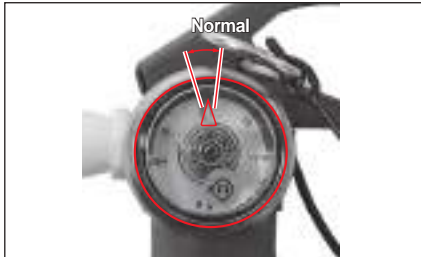

- Check at least once a month if the needle on the pressure gauge of the extinguisher is in the normal range.

If there is a pressure loss or other abnormalities, have the extinguisher serviced immediately.

- The lifetime of the extinguisher is approximately 5 years when it is maintained under normal conditions.
After 5 years have passed, it should be inspected and confirmed by a fire fighting equipment company every 2 years.
- After using the extinguisher, be sure to release the chemical (ABC powder) from the inside of the extinguisher completely and refill with an ABC powder fire extinguishing agent.
If it is left unattended for a long period of time, the contents may become hardened and it cannot be used. Shake the extinguisher periodically.

In the event of a heavy snow

When there is a heavy snow, do not panic and refer to the following tips for actions.

- Always listen to the radio and use the expressway information call number.
- Drive slowly on a curved road, an uphill road or a bridge.
- Avoid parking or leaving the vehicle on the shoulder of the road that cause inconvenience for snow removal operations.
- Be sure to leave your contact information when you leave the vehicle unavoidably.
- Drive slowly while securing a safe distance between vehicles.
- Avoid using the brake as much as possible, and use the regenerative braking system to slow down gradually and stop your vehicle.
- Clear the snow around the vehicle from time to time.

<https://www.automotive-manuals.net/>

6. Periodic Checking and Maintenance

You can check the necessary periodic check and maintenance methods in detail for safe and pleasant vehicle driving.

Maintenance Schedule

Maintenance item	Daily check	Change interval
High voltage battery coolant	○	Every 4 years or 80,000 km
Cabin heater coolant	○	Every 5 years or 200,000 km
Driving and charging system coolant	○	Every 5 years or 200,000 km
Brake fluid	○	Every 2 years
Brake pipe and hose	-	Check at first 1,000 km of driving / then check every 20,000 km of driving or every year /replace if necessary
Brake pad and disc	-	Check every 10,000 km of driving / adjust or replace if necessary
Decelerator fluid	-	Change every 24 months or 40,000 km
Drive shaft, boot	-	Check every 10,000 km of driving (fill or change grease if necessary)
A/C filter	-	Replace every 10,000 km of driving (Under severe conditions such as dusty road, unpaved road, and excessive A/C and heater operation, shorten the replacement interval)



Warning

For all consumables and oils, use genuine parts specified by us.

Oils capacity/specifications

Category		Capacity	Specifications
Coolant	Heater cabin coolant	LHD	≈ 1.9 ℓ KG Mobility genuine coolant Anti-Freeze: SYC-1025 (LLC)
		RHD	≈ 1.7 ℓ Anti-Freeze: Water = 50:50
	High voltage battery coolant		≈ 7.1 ℓ KG Mobility genuine coolant Anti-Freeze: SYC 306E Anti-Freeze: Water = 50:50
	Drive motor coolant	H/P	≈ 5.1 ℓ KG Mobility genuine coolant Anti-Freeze: SYC-1025 (LLC)
Non H/P		≈ 5.0 ℓ Anti-Freeze: Water = 50:50	
Brake fluid		As required	KG Mobility genuine oil (DOT4)
Decelerator		≈ 1.3 ℓ	Castril BOT384 (Recommended), Castrol ON D2

6



Warning

- Always use KG Mobility genuine oils and liquids.
- Do not mix oils and liquids with other products. It can damage corresponding parts of the vehicle.
- When replenishing or changing oils and liquids, check the oil level.

Periodic Checkup And Change Interval

Table for check and change intervals under normal conditions

Category		Daily check	Check and change intervals			Remarks
			Every 10,000 km of driving	Every 20,000km of driving	Every 30,000km of driving	
Motor room	Check and replenish high voltage battery coolant	<input type="radio"/>				-
	Check and replenish cabin heater coolant	<input type="radio"/>				-
	Check and replenish driving and charging system coolant	<input type="radio"/>				-
	Check connection of cooling system	<input type="radio"/>				-
	Check low voltage (12 V) battery	<input type="radio"/>				
Power steering	Steering wheel free play	<input type="radio"/>				
	Re-tighten power steering mounting bolt		Check			
	Check each steering system connection, gearbox, boot		Check			
	Check and replace ball joint		Check			Adjust or replace if necessary

Category		Daily check	Check and change intervals			Remarks
			Every 10,000 km of driving	Every 20,000km of driving	Every 30,000km of driving	
Brake	Check and replenish brake fluid	○				
	Change brake fluid		Change every 2 year			
	Brake pipe and hose		Check			Check and adjust or replace if necessary
			Check every 20,000 km of driving or every year /replace if necessary			
	Brake pad and disc		Check			Adjust or replace if necessary
	Brake pedal operation and free play					
	Parking brake operation		Check			Check and adjust frequently
Drive system and chassis	Decelerator fluid		Change every 24 months or 40,000 km			Add or change oil as necessary
	Check drive shaft and boot		Check			Fill or change grease if necessary
	Lower bolt/nut of chassis and body check-tighten, ball joint grease leakage check, free-play/tightness		Check			Adjust or replace if necessary
Tire and wheel	Tire pressure check and inflation	○				
	Tire wear		Check		Check	
	Tire rotation		Change every 5,000km of driving			
	Wheel balance and wheel alignment		Check			
	Wheel nut/bolt tightness condition		Check			

Category		Daily check	Check and change intervals			Remarks
			Every 10,000 km of driving	Every 20,000km of driving	Every 30,000km of driving	
Other check items	Various oil leakage and coolant leakage	<input type="radio"/>				
	Various system test with diagnostic device		Check			
	Seat belt and buckle operation status	<input type="radio"/>				
	Whether warning lamp and ON indicator illuminated or not	<input type="radio"/>				
	Operating status of outdoor/indoor lamps	<input type="radio"/>				
	Check and adjust headlamp aiming angle				Check	
	Wiper, washer operation and mirror status	<input type="radio"/>				
	Wiper blade check and replacement	<input type="radio"/>				
	Washer fluid level check and fill up if necessary	<input type="radio"/>				
	Hood, door, tailgate lubrication and operation		Check			Adjust or replace if necessary
	Replace A/C filter		Replace			Check within 10,000 km of driving and replace if necessary
	Cooling/Heating system operation	<input type="radio"/>				

Table for check and change intervals under demanding conditions

Maintenance item	Check and change intervals	Driving conditions
Brake pad and disc	Check frequently and adjust or replace if necessary	2, 3, 4, 5, 6, 7, 8
Ball joint	Check frequently and adjust or replace if necessary	2, 3, 4, 5, 6
Drive shaft and boot	Check frequently and adjust or replace if necessary	2, 3, 4, 5, 6, 7
A/C filter	Check frequently and adjust or replace if necessary	2
Decelerator fluid	Change every 20,000 km of driving	1, 3, 4, 5, 6, 7, 8, 9, 10

When driving under the following demanding conditions, check frequently by shortening the check and replacement interval and replace, if necessary.

- 1 Driving a short distance repeatedly
- 2 Driving in a dusty and sandy area
- 3 Operating in a place with heavy traffic
- 4 High frequency of driving in rough roads such as sand, gravel road, snowy road and unpaved road
- 5 Frequent driving up mountain roads or in hilly terrain
- 6 Using the vehicle as a police car, taxi, fleet, tow truck (trailer towing), etc.
- 7 Driving at a high speed (170 km/h) frequently
- 8 Frequent stop-and-start driving
- 9 High frequency of driving in hot areas (30°C or higher)
- 10 Frequent acceleration and sudden departure

Checking Motor Room

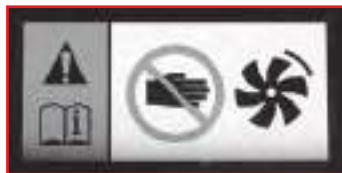
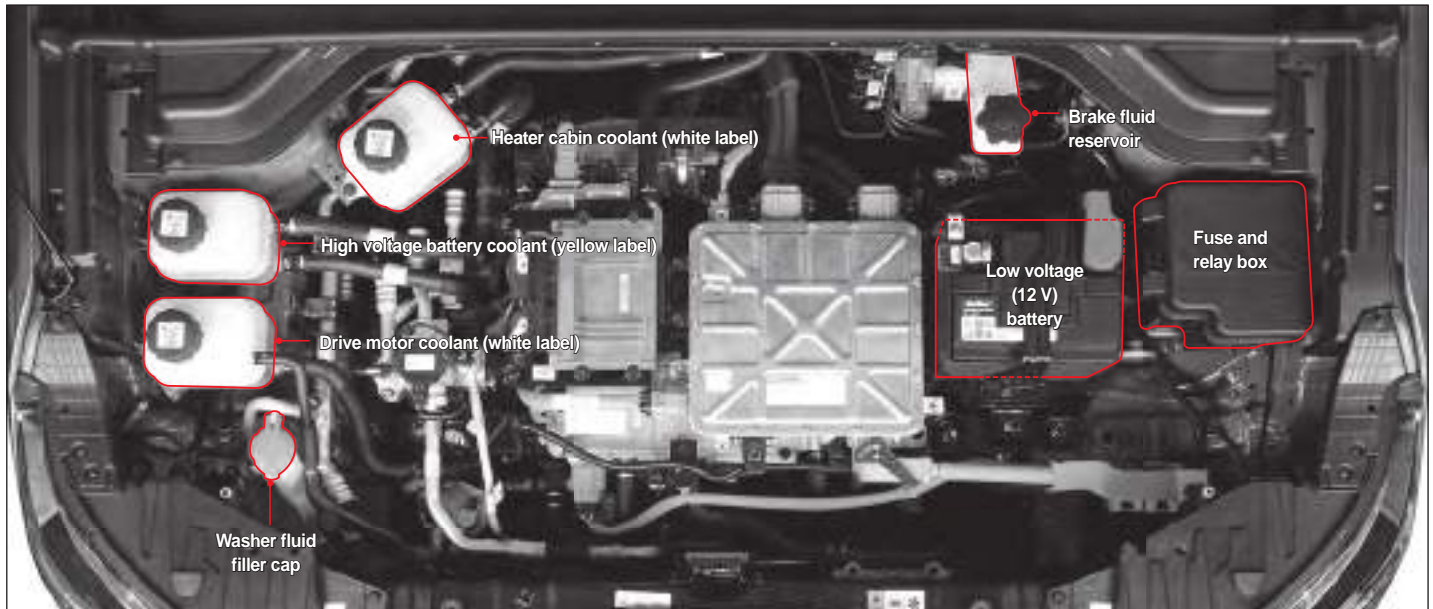

Warning

- Do not put your hand in the rotating part of the motor room cooling fan. This can lead to serious injuries.
- Electric shock can lead to death.
- Do not remove the cover and connector.
- Do not disassemble internal parts.

Coolant

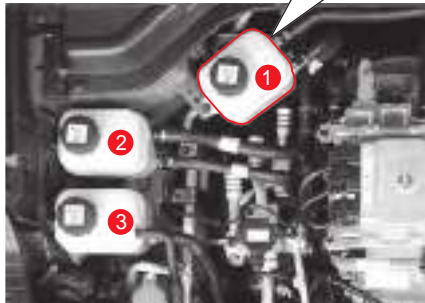

- ① Heater cabin coolant auxiliary tank
- ② High-voltage battery coolant auxiliary tank
- ③ Drive motor coolant auxiliary tank

Warning

- Low coolant level can cause poor performance and fire due to overheating the high voltage battery, poor performance due to overheating the drive system, and poor indoor heater performance. Check coolant level at regular intervals.
- For coolant, always use our genuine antifreeze. If the product is supplemented with other types of products or non-standard products, a chemical reaction can form a scale in the cooling system and block coolant flow, causing overheating.

Notice

- The antifreeze mixture ratio at the time of vehicle delivery is 45% for 1 and 3, and 50% for 2.

Level Check & Replenishment

Park the vehicle on level ground and apply the parking brake.
Stop the motor room and wait until it cools.

- 1 The coolant level should be at the coolant tank's MAX mark.
- 2 Mixing coolant and replenishing water can cause problems in the vehicle. So, if the coolant level is close to or below the minimum mark, have the system checked and serviced by a KG Mobility Authorized Service Center.

Caution

- Avoid any direct contact of the coolant to the painted body of the vehicle.

Warning

- Use only the KG Mobility genuine coolant.

Brake and clutch fluid

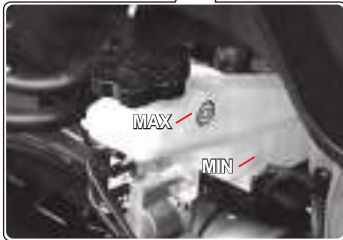
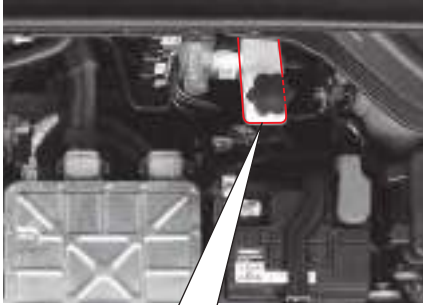

Specification and Replacement

Specification	DOT 4
Service interval	Every 2 years

Level Check and Replenishment

- Check the brake fluid on a level ground.
- The fluid level should be between the “MAX” and “MIN” levels on the reservoir.
- Check the level on a level surface. If it drops to or below the MIN mark, refill the tank with the specified fluid. Only use the specified fluid.

Caution

- Be careful not to let any foreign materials enter the tank when adding the fluid.
- Do not add the fluid above the “MAX” level.
- Do not allow the fluid to make contact with the body paintwork.
- After adding the fluid, tighten the cap securely.
- If frequent refills are required, have the system checked by a KG Mobility Dealer or KG Mobility Authorized Service Center.

Warning

- Use only the KG Mobility genuine brake fluid.
- Do not allow the fluid to make contact with skin or eyes. If contact happens, rinse affected areas immediately with plenty of water. If irritation persists, consult a doctor.
- The fluid gradually decreases according to brake pad wear. A sudden drop of the fluid level may indicate a leak in the system. In this case, have the system checked by a KG Mobility Dealer or KG Mobility Authorized Service Center.

Washer fluid

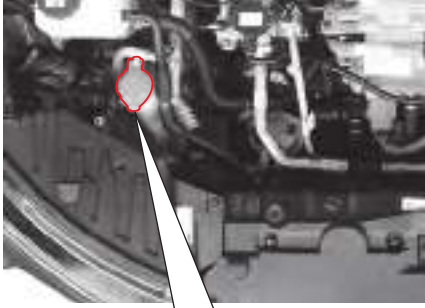

Frequently check the washer fluid level and add the specified product as needed.

In winter, use only the specified washer liquid for winter season.

! Caution

- If you use plain water as washer fluid, it will freeze during the winter and damage the washer fluid reservoir and motor. Use only the specified washer fluid.
- If you operate the washer switch without washer fluid, the motor could be damaged due to overloads. Therefore, if there is no washer fluid, do not operate the washer motor.
- Operating the wipers on a dry surface on the windshield or rear window without any washer fluid may cause damage to the glass. Operate the wipers after sufficiently spraying the washer fluid.
- Avoid any spills of washer fluid on the body paint of your vehicle during replenishment. If washer fluid spills onto your hand or other body part, wash it away under a clean water flow.
- There is no independent washer reservoir for the tailgate window. The front washer reservoir is also for the tailgate window.

! Warning

- The washer fluid includes flammable materials to prevent freezing. It could cause a fire when directly contacted with flames. When checking the washer fluid, avoid the flames near the washer fluid tank.
- If antifreeze is used as the washer fluid, it will decrease your visibility through the windshield and may cause an accident.

Low voltage battery (12V)

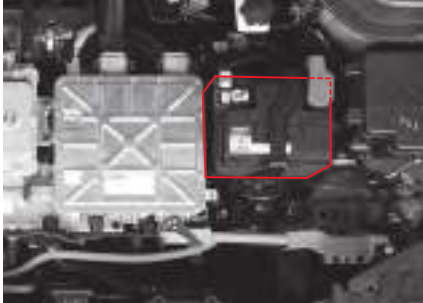

If the low voltage battery charge warning lamp  illuminates while driving, there is a fault in the charging system of the vehicle including the low voltage (12 V) battery. In this case, immediately have the vehicle checked and serviced at a KG Mobility Dealer or KG Mobility Authorized Service Center.

Battery Maintenance

- Make sure the terminal connections are securely tightened.
- If the terminals are corroded, clean them with a wire brush or sand paper.
- Check the battery for any cracks, damages or leaks. Replace it if necessary. To remove any battery fluid on the battery surface, wear rubber gloves and wipe the fluid out with a wet-soapy cloth.

Specification

Specification	MF / 12V - 50AH
Capacity	50AH

Caution

- If you disconnect the battery terminal when the vehicle is running, electrical systems could be damaged.
- To remove the battery cable, disconnect the negative cable first and be careful on the battery terminal polarity when you connect the cables. The negative and the positive should not be confused.
- The polarity of the battery, i.e. the connections for positive and negative cables, must not be interchanged. Never short-circuit the battery.
- When the ambient temperature is too low, the battery capacity will drop and can be frozen.
- Keep the battery electrolyte at its specified level. If the electrolyte level is higher than the MAX level, it can overflow during battery charging and if the electrolyte is overcharged, the battery can explode.
- Only use a battery with the approved voltage and capacity. Otherwise, an incompatible battery can catch fire.







Warning

- The battery has acid that can burn you. And its gas can explode. You can get serious injuries if you are not careful. Keep naked flames, sparks and smoking items away from the battery.
- Loosely connected battery terminals can set up sparks. These sparks can cause a fire with flammable gas. Therefore, tightly connect the terminals.
- At night, if you need to check the motor room, do not use a lighter, but only use a battery-powered flashlight.
- Because the battery electrolyte is very strong acid, avoid any direct contact of the battery electrolyte on your skin or vehicle's body. If the acid contacts your skin, thoroughly wash your skin with fresh water and see your doctor. Do the same on your vehicle.
- Wear eye protection when working with a battery. If working in a closed area, keep good ventilation.



Warning

- Always use the battery with correct voltage for the vehicle. Otherwise, there is a risk of fire.
- Observe the indications on the battery.
 -  Always read the safety instructions in the User Manual before working on the battery.
 -  The battery cell always contains highly flammable hydrogen gas which may explode if ignited. Be sure to keep it away from a cigarette, a spark or other flames.
 -  Wear a protective goggle when charging the battery or performing any work. In addition, ensure adequate ventilation of the enclosed space.
 -  The battery electrolyte solution contains a highly corrosive sulfuric acid. Be careful not to contact it with skin, eyes, clothes or paint. In particular, keep out of the children's reach.



When in contact with the skin, wash off the contact area; In case of eye contact, flush with running water for at least 15 minutes, and seek medical help immediately.



The hydrogen gas in the battery is highly flammable and may explode if ignited.



Do not throw out used battery as this pollutes the environment and is hazardous to our health. For environmental protection, used, properly dispose of used battery at designated disposal sites only.

Checking the wipers and replacing the blade

Replacing the blade of windshield wiper

- 1 Lift the wiper arm up with the vehicle turned off.

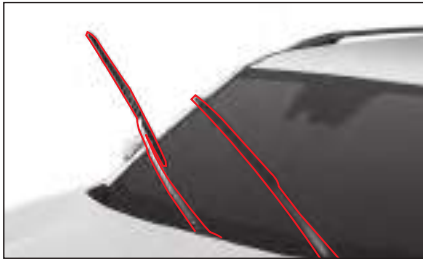

- 2 Press the wiper blade retainer (1) and pull the wiper blade out in the arrow direction (2).

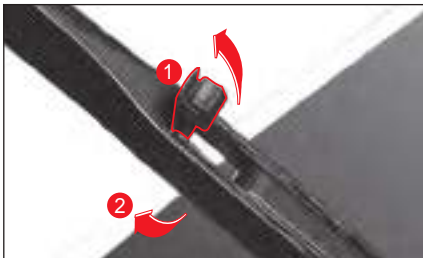

- 3 Insert a new wiper blade.
- 4 Put the wiper arm down.

Replacing the blade of rear window wiper

- 1 Lift the wiper arm up with the vehicle turned off.

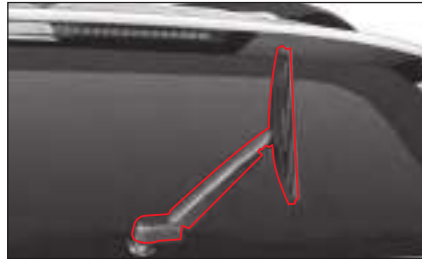

- 2 With the wiper blade lifted to its side, remove it by pulling it in the arrow direction.



- 3 Insert a new wiper blade until a clicking sound occurs.
- 4 Put the wiper arm down.

Specifications of wiper blade

Windshield wiper		Rear window wiper
Driver seat side	Front passenger seat side	
600mm	450mm	275mm
24 "	18 "	11 "

Warning

- If there is a problem in wiper operation, it can be a fatal obstacle to safe driving when it rains or snows. Never drive the vehicle on a snowy day or a rainy day if the wiper does not operate.
- Holding the wiper arm or placing your hand near the operating part when the wiper is operating may cause an injury.



Caution

- Do not open the hood with the wiper lifted up. Doing so may damage the hood and the wiper.
- Do not operate the wiper when the windshield is dry.
- Do not wipe the windshield or the rear window with a towel stained with oil or wax. If the windshield or the rear window is stained with oil or wax, an abnormal noise may occur when you operate the wiper or light is reflected at night, making you unable to see the front well.
- When you check the wipers, be sure to lift the driver seat side wiper arm up first and then lift the front passenger seat side wiper arm up.
- When you lift the driver seat side wiper arm up, it may interfere with the front passenger seat side wiper arm, but that is normal.

Checking and replacing fuses and relays

If an electrical system does not operate normally, check the relevant fuse first. If the fuse is blown, replace it with a fuse of the same capacity.

Warning

- Not using a bulb or using a bulb with the capacity that does not meet the specifications or modifying the HID bulb or LED lamp wiring arbitrarily may cause the fuse disconnection, malfunction or damage other wiring-related devices.

Caution

- Removing a fuse while the electricity is being supplied may damage the relevant electrical system. Be sure to replace a fuse after turning off all electrical systems.
- Replace the fuse with a new one of the same capacity that meets the specifications.
- If the replaced fuse is blown continuously, have your vehicle checked and serviced at a KG Mobility Authorized Service Center.

Notice

- Refer to the label attached to the fuse and relay box cover for the capacity and name of fuse.

Motor room fuse and relay box

Open the hood and lift the fuse box cover up with the locking lever (1) in front of the motor room compartment fuse box cover pressed.

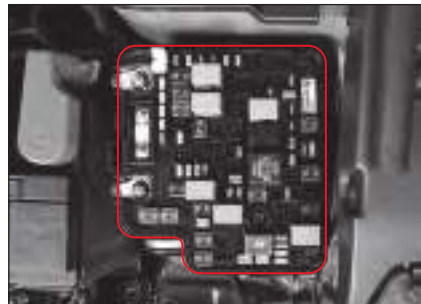

Interior fuse box

Open the driver seat door and open the interior fuse box by inserting your finger on the groove of the interior fuse box cover (1) and pulling it.

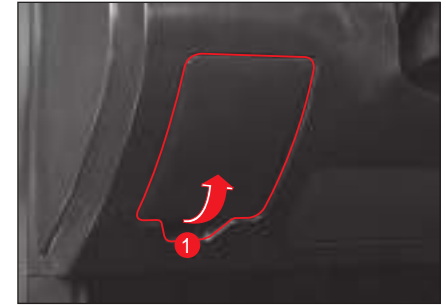

Checking and replacing fuses

- 1 Turn off all electrical systems and the vehicle.
- 2 Open the cover of the motor room compartment fuse box cover or the interior fuse box.
- 3 Check the relevant fuse by referring to the block diagram of the fuses shown inside of the fuse box cover.
- 4 Pull out the relevant fuse by using the fuse puller.
The fuse puller is provided in the motor room compartment fuse box.

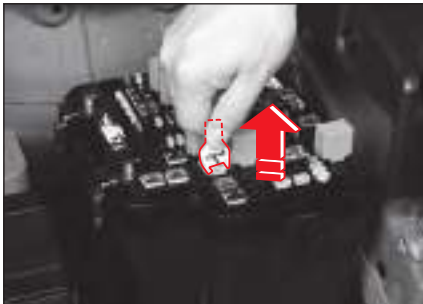

- 5 Check visually whether the fuse is blown or not.
- 6 If the fuse is normal, insert it back to its original position.
- 7 If the fuse is blown, check the capacity indicated on top of the fuse and replace it with a new fuse of the same capacity.

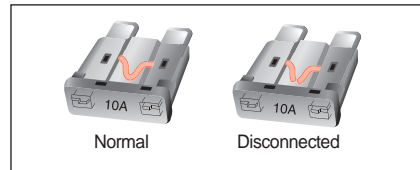
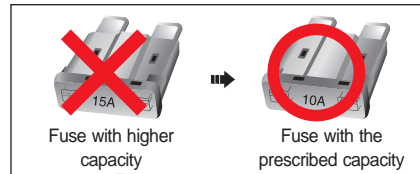

Warning

- Using steel wire, copper wire or aluminum foil instead of the fuse may cause a fire due to the overload of the electrical system. Always use a fuse with the prescribed capacity.
- Never use a fuse with a capacity higher than the prescribed capacity indicated on the fuse and relay box since a fuse with higher capacity may damage electrical systems or cause a fire.
- When the fuse is disconnected, use a normal fuse with the prescribed capacity.

Notice

- Spare fuses for each capacity are provided in the fuse and relay box. If you use a spare fuse, replenish with a new one immediately. The capacity is indicated on top of the fuse.

Checking and replacing the lamps

Specifications of lamps and checking

Specifications and quantity of lamps and bulbs

Classification				Quantity	Specifications
Exterior lamp (front side of the vehicle)	Head lamp	High beam	Bulb	2	H1-55W
			-	-	LED
		Low beam	Bulb	2	H7-55W
			-	-	LED
	Turn signal/sidelight/ daytime running light (DRL)			-	LED
	Turn signal	Bulb	2	PY21W	
		-	-	LED	
	Fog light	Front	-	LED	
		Rear	Bulb	2	P21W
	Puddle lamp			-	LED

Classification			Quantity	Specifications
Exterior lamp (rear side of the vehicle)	Rear lamp	Stop lamp	-	LED
		Tail light/Stop lamp	-	LED
	Backup lamp		2	W16W
	Turn signal		2	PY21W
	License plate lamp		2	W5W
	High mounted stop lamp		-	LED
Interior lamp	Front room lamp	Bulb	2	10W
		-	-	LED
	Center room lamp	Bulb	2	10W
		-	-	LED
	Luggage room lamp		1	8W
	Sun visor/mirror lamp		2	5W
	Glove box lamp		1	5W
	Dashboard mood lamp (front passenger seat side)		-	LED
	Front door mood lamp		-	LED

Checking the lamps

Operate the ON/OFF switch of various lamps to see if the lamp turns on or off normally.

If the lamp does not turn on, check the lamp in the following order and replace the relevant part if it is abnormal.

- Fuse
- Bulb

If the fuse and the bulb are normal, have your vehicle checked and serviced at a KG Mobility Authorized Service Center.



Caution

- Only use a bulb with the prescribed capacity when replacing the lamp.
- Be sure to disconnect the negative (-) battery cable or turn off the vehicle before replacing the lamp.
- Removing the lamp cover forcibly may damage the lamp cover so that it may not be used again, so caution should be taken when removing the lamp cover.
- Before replacing a bulb, be sure to turn off the relevant lamp.
- Do not touch the bulb with your hands during or right after bulb operation since there is a possibility of a burn.
- Holding the glass part of the bulb with your hand may leave a fingerprint, dust or moisture on the bulb, reducing its life or exploding it. In such case, wipe the glass part with a soft cloth.
- Be sure to have the aiming angle of the head lamp adjusted by a KG Mobility Authorized Service Center.

- The internal surface of the head light and braking light lamp may be fogged temporarily under conditions such as rain or car washing. This is dew condensation according to a temperature difference between the inside and the outside of the lamp and it is not a functional problem. However, if water enters into the lamp or a large water drop occurs inside the lamp, contact a KG Mobility Authorized Service Center.
- To replace an exterior lamp bulb, visit a KG Mobility Authorized Service Center.

Position of exterior lights and lamps

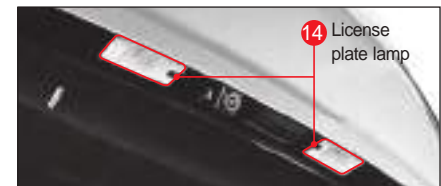
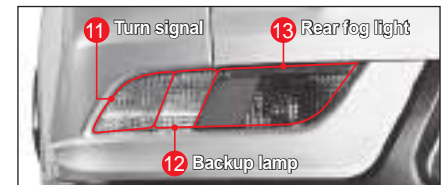
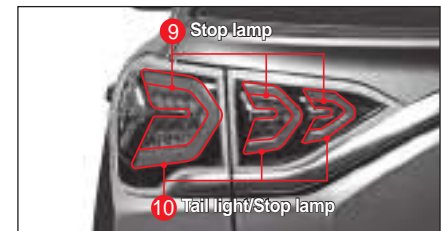
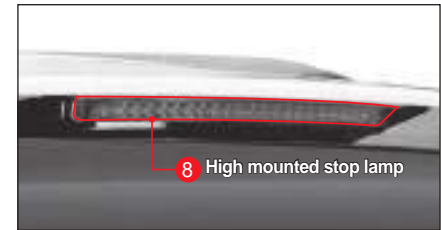
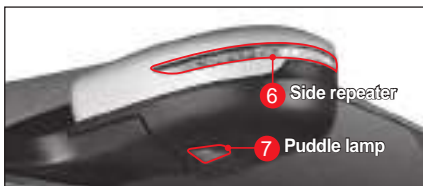
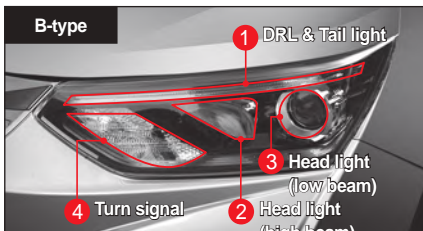
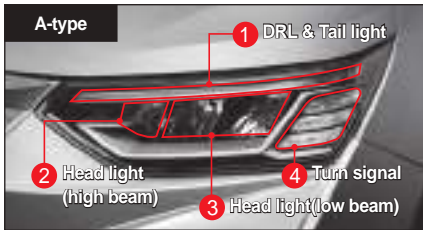

Replacing exterior lamps

All lamps except for the following lamps should be checked and replaced at a nearby KG Mobility Authorized Service Center.

- Rear turn signal lamp
- Backup lamp

Warning

- Replacing with a lamp that does not meet the specifications may cause the disconnection of a fuse, malfunction or a fire.
- Before replacing the lamp, park the vehicle at a safe place, turn off the vehicle and disconnect the negative (-) battery cable. (After connecting the battery again, reset some functions of the vehicle.)
- Do not touch the bulb with your hands during or right after bulb operation since there is a possibility of a burn.

Caution

- When you install the lamp again after replacing it, install the socket firmly to the hole by turning it clockwise.
- Be sure to use genuine parts for the lamp.
- Do not install an additional lamp or LED for the lamps installed previously on the vehicle.

To replace license plate lamp

1 Unscrew the license plate mounting screws.

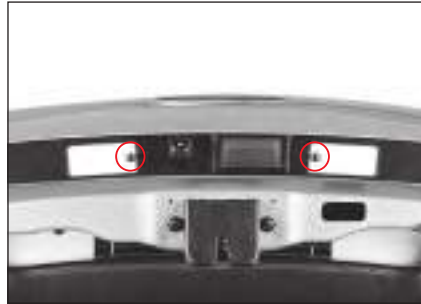

2 Remove the license plate assembly.

Caution

- Be careful not to damage the vehicle body and the rear combination assembly.

3 Turn the license plate assembly clockwise to remove the bulb socket.



4 Remove the license plate from the socket and replace it with new one with right specifications.



5 Once replacement is completed, assemble the lamp in reverse order of removal.

Position of interior lamps

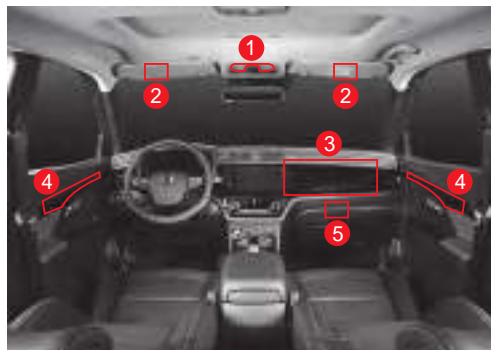
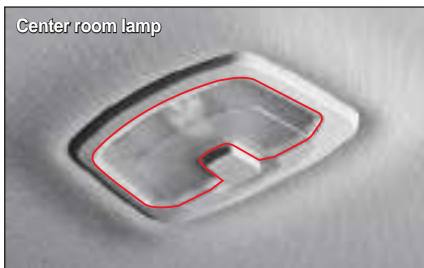
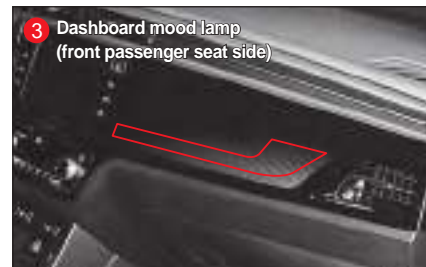
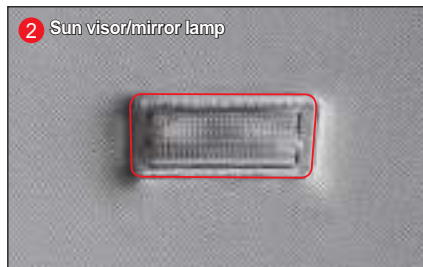
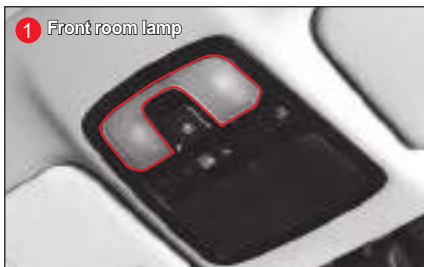

Replacing the interior lamps

Replacing the front room lamp

- 1 Turn off the room lamp and remove the lamp cover using a flat-bladed screwdriver.

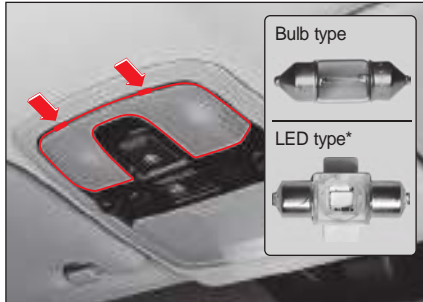

Caution

- Be sure to remove the lamp cover from the part marked with an arrow (rear part) first. Removing it from the part on the opposite side first may damage the cover.

- 2 Remove the lamp by pulling it down (arrow direction) and replace it with a new one.



- 3 After replacing it, install the cover again.

Replacing the center room lamp

- 1 Turn off the room lamp and remove the lamp cover using a flat-bladed screwdriver.

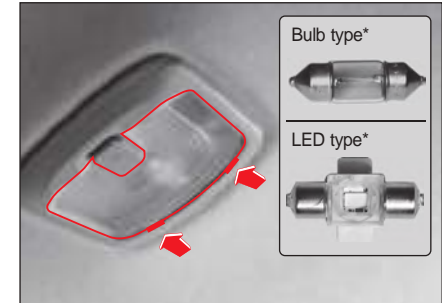

Caution

- Be sure to remove the lamp cover from the part marked with an arrow (front part) first. Removing it from the part on the opposite side first may damage the cover.

- 2 Remove the lamp by pulling it down (arrow direction) and replace it with a new one.



- 3 After replacing it, install the cover again.

Replacing the sun visor/mirror lamp

- 1 Turn off the vehicle and remove the lamp cover using a flat bladed screwdriver.

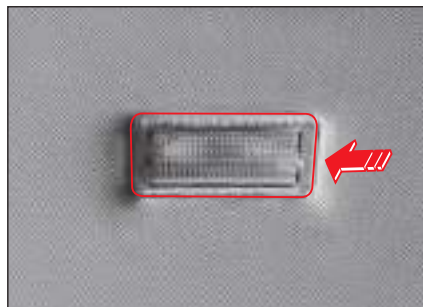

Caution

- Be sure to remove the lamp cover from the part marked with an arrow first. Removing it from the part on the opposite side first may damage the connector and the cover.

- 2 Remove the lamp and replace it with a new one.

At this time, avoid leaving a fingerprint or a foreign material on the surface of the bulb.

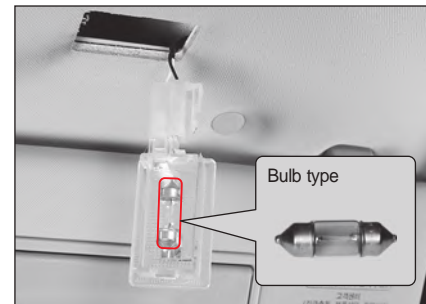

- 3 After replacing it, install the cover again.

Replacing the glove box lamp

- 1 Disconnect the negative (-) battery cable and remove the lamp cover using a flat bladed screwdriver.

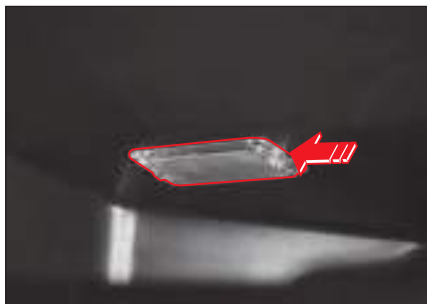

Caution

- Be sure to remove the lamp cover from the part marked with an arrow first. Removing it from the part on the opposite side first may damage the connector and the cover.

- 2 Remove the lamp and replace it with a new one.

At this time, avoid leaving a fingerprint or a foreign material on the surface of the bulb.

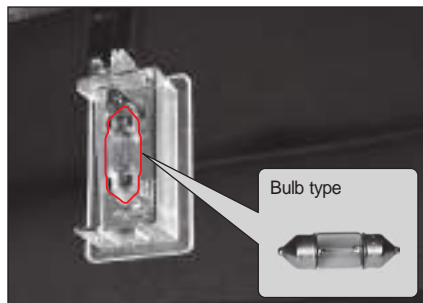

- 3 After replacing it, install the cover again.

Replacing the A/C filter

In any of the following cases, replace the A/C filter even if the replacement interval has not come near.

- If an unpleasant smell comes out when you operate the A/C after it is not operated for a long period of time
- If the cooling and heating performance or air blowing performance is lowered

Caution

- Replace the A/C filter every 10,000 km. However, if the vehicle is driven on a road where the air is heavily polluted, an unpaved road or the A/C and the heater are used excessively, replace the A/C filter earlier than the replacement interval.
- If the A/C filter is contaminated, the cooling performance may be lowered and an unpleasant smell may occur when you operate the A/C.
- Be careful not to switch the installation direction when replacing the A/C filter.

- 1 Remove the front side (2) fixed portion of the A/C filter cover at the position indicated by the arrow at the bottom of the glove box by separating it in the direction of the arrow (1).

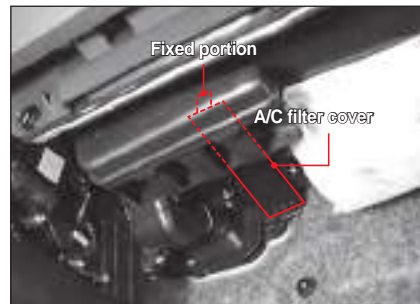
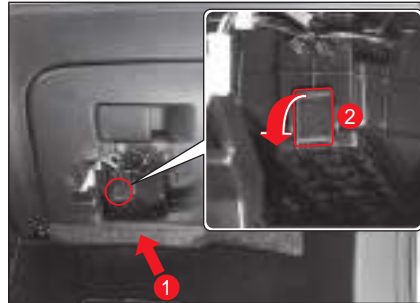

- 2 Take out the A/C filter.

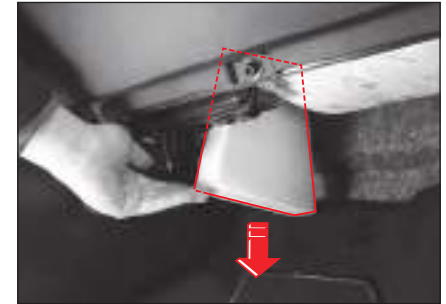

- 3 Replace with new one. Make sure that the "AIR FLOW" arrow faces toward the driver seat.

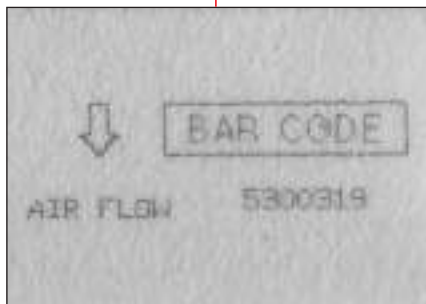
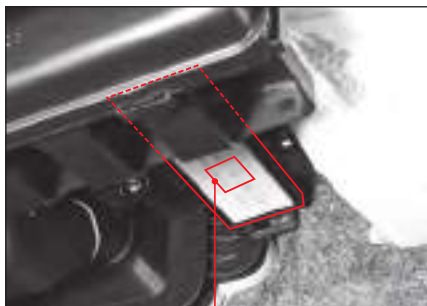

- 4 Once replacement is completed, fit the A/C filter cover.

Checking the tires and wheels

Checking the tire pressure

Check the tire pressure before driving the vehicle or when the tires are cooled down completely.

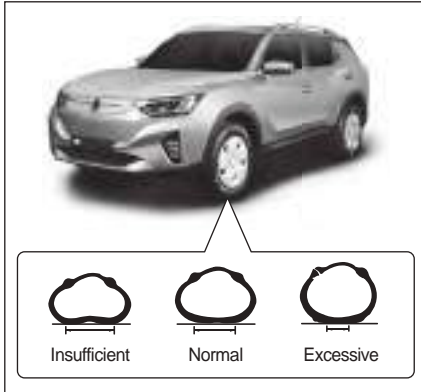

Caution

- If the tire pressure is higher or lower than the prescribed value, the riding comfort or steering stability are lowered and the tires are easily damaged and uneven tire wear occurs. Be sure to adjust the tire pressure to the prescribed value.

Prescribed tire inflation pressure

Classification	Type	Wheel	Tire pressure
Driving tire	215/65R17	6.5JX17	36 psi, (2.48 bar)

Notice

- The prescribed tire inflation pressure is measured when the tire has been cooled down properly at room temperature. If you need to drive the vehicle on an expressway for a long period of time, increase the tire inflation pressure by 4-5psi from the prescribed value on the table.

Wheel alignment status and the balance between tires and wheels

If the wheels are not aligned as prescribed, it leads to uneven or accelerated wear of the tires and causes the vehicle to lead to one side while driving.

If the tires and wheels are not balanced, it may lead to vehicle vibration or uneven wear of tires.

In such case, have your vehicle checked and maintained at a KG Mobility Authorized Service Center.

Checking the status of tire wear

Check the status of tire wear on the contact surface of the tire along the marked part. Replace the tire before the tire tread goes down below the wear limit.

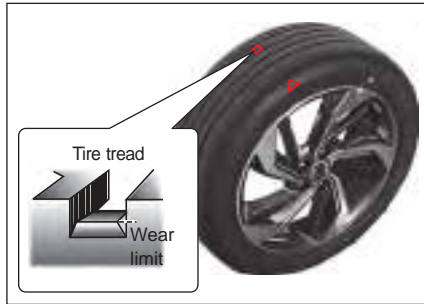

Warning

- Check the tire for damage or the status of tire wear frequently and replace if necessary.
- If the tire is worn excessively, the braking distance may increase or the steering wheel may become heavier. Also, the tire may be blown, resulting in an accident.

Rotating the tire positions

When a spare tire is not included

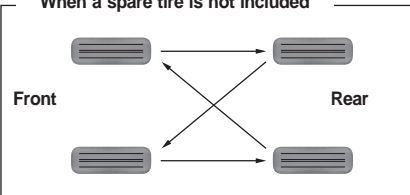

Directional tire

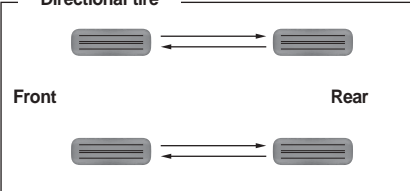

☞ Refer to "When you have rotated the tires" (p.2-33)

Warning

- Be sure to replace a tire at a KG Mobility Authorized Service Center or a professional tire shop.
- Be sure to install the same manufacturer's tires with the same specifications, not mixing different types of tires.

Snow tire

Use snow tires in order to drive the vehicle safely on a snowy road or an icy road during winter.

The snow tires should be installed on all 4 wheels.

Warning

- If the snow tires for driving on a snowy road and an icy road are not installed, drive the vehicle as slowly as possible.
- The snow tire with the driving direction arrow on its side wall should be installed according to the driving direction.
- The snow tire is manufactured in consideration of the characteristics of road surface during winter. However, it is an auxiliary aid, so be sure to install the snow chains on a snowy road and an icy road and drive the vehicle as slowly as possible for safe driving.
- Replace the snow tires with ordinary tires when the winter has passed. Store the snow tires in a cool place with no direct sunlight and be careful not to allow them to come into contact with oil, grease or fuel.

Tire chain

- Install the tire chains on the front wheels for a 2-wheel drive vehicle and install the tire chains on both the front and rear wheels for a 4-wheel drive vehicle. If it is impossible, be sure to install the tire chains on the rear wheels.
- In case of a vehicle equipped with aluminum wheels, the wheels may be damaged if the tire chains are used. Therefore, use snow tires instead of the tire chains. If it is impossible, use the wire-type tire chains.
- When the tire chains are installed, drive the vehicle at a prescribed speed recommended by the chain manufacturer or at a speed of 30 km/h or less.
- If you hear a sound of the tire chain hitting the vehicle body, stop the vehicle immediately, check the installation status of the tire chains and tighten the tire chains if necessary.
- Take the tire chains off immediately on a normal road to prevent the chains from being damaged.
- Do not use the tire chains on a normal road, use only on a snowy road or an icy road.



Warning

- **After driving the vehicle with the tire chains installed for a certain distance (0.5~1 km), check the installation status of the tire chains and for any damage to the vehicle body. If the tire chains are loose, tighten them again.**
- **Be sure to use a tire chain that meets the specifications and install it correctly. If the tire chain does not meet the specifications or is installed incorrectly, the vehicle may be damaged or a serious problem in the steerability and safety of the vehicle may occur.**

Cautions for checking the tires and wheels



Caution

- **Be sure to use the same manufacturer's tire with the same specifications for all tires in order to maintain the characteristic of the vehicle safely.**
- **Be sure to check the status of tire wear and the tire pressure before driving the vehicle.**
- **The tire pressure and tightening status of tire wheel nuts should be checked frequently. Be sure to check the vehicle condition, tire pressure and the tightening status of tire wheel nuts before driving the vehicle for a long distance.**
- **Only use the same manufacturer's tires that meet the specifications. If the tire that does not meet the specifications when installed, you cannot operate the steering wheel normally, the fuel consumption may increase and the driving system or braking system of the vehicle may become abnormal. In addition, the vibration of the steering wheel and uneven tire wear may occur when you drive the vehicle at a high speed.**
- **Installing a tire that does not meet the specifications or a retreaded tire voids the warranty repair.**

- Check the tires and wheels always before driving the vehicle. If the wheels are damaged, the tire pressure may decrease and the tires may be damaged.
- If a tire has been impacted by a stone or any other objects while driving, have your vehicle checked and serviced at a KG Mobility Authorized Service Center immediately.
- Do not mix the tires and wheels installed when the vehicle was shipped with other tires and wheels. Doing so may affect the driving stability of the vehicle, causing an accident.
- Check the status of the emergency tire service kit. Always check the operation status of the compressor and the preparation of sealant.
- Be sure to check and add the tire pressure before driving the vehicle for a long period of time or at a high speed. Driving the vehicle at a high speed with low tire pressure may cause the tires to burst due to the standing wave effect, resulting in a risk such as a rollover.

Vehicle management during winter

Various unfit elements for driving occur on a road in winter, so make sure to prepare in advance in order to respond properly.

Starting the vehicle and driving the vehicle

In winter, the resistance of the motor drive may increase and the performance of the battery may decrease. Please keep the SOC high in order to maintain the performance of the EV battery.

Managing the motor coolant

Be sure to check the concentration of coolant before the temperature begins to drop.

Managing washer fluid

Use only genuine washer fluid that does not freeze in cold weather.

If the washer fluid freezes due to the use of a non-standard washer fluid it may damage the washer motor and interfere with safe driving.

Installing a snow tire

It is recommended to replace the tires with snow tires during winter in order to prevent the vehicle from slipping on a snowy road or an icy road.

Managing the A/C

If the A/C is not used for a long period of time, the lubrication inside the A/C is not carried out. As a result, the packing inside of the A/C may be hardened that may lead to refrigerant leak and malfunction due to rusting.

It is recommended to operate the A/C for 5 to 10 minutes once a week regardless of season in order to maintain the performance of the A/C continuously.



Caution

- Do not remove the refrigerant in winter even if the A/C is not used.



Caution

- Drive the vehicle at a lower speed than usual if the snow tires are installed.
- Install the tire chains in a correct way. Failure to do so may damage the wheel house or the vehicle body.

Other maintenance

- Prepare sand bags, snow chains, shovel, gloves and old clothes in the vehicle in advance in preparation for driving the vehicle in the countryside or heavy snow.
- Do not drive too fast, accelerate or brake or steer the vehicle suddenly on a snowy road or an icy road.
- Maintain a distance of at least twice the usual distance from the vehicle in front of you when driving on snowy or icy roads, and use the regenerative braking system properly to stop your vehicle.
- Do not operate the wiper when it is frozen. Doing so may overload, damaging the wiper motor.
- When you drive the vehicle on a snow-covered road, a large amount of snow may build up under the wheel house, making it difficult for you to operate the steering wheel, so check and remove it frequently.
- When you have passed a road where calcium chloride is sprayed, wash your vehicle as soon as possible to prevent the bottom part of the vehicle from being corroded.

- If you park the vehicle in a snowy place, the brake system may freeze, reducing the braking force while driving. In such case, depress the brake pedal frequently while driving the vehicle at a low speed, restoring the braking force, and then drive the vehicle normally.
- Do not start off in the vehicle forcibly while the parking brake is frozen. Doing so may damage the vehicle. Be sure to start off in the vehicle after the parking brake has melted.

Cautions for parking during winter

- When the temperature falls down below zero, the parking brake may not be released due to the freezing of EPB-related devices.
- When you park the vehicle on a flat and safe place in weather with below zero temperatures, use a chock on the wheels after parking instead of using the EPB.

Warnings for self-maintenance

When the vehicle is checked and serviced by the driver, proper knowledge and special attention are necessary for preventing injury and damage to the vehicle.

Warning

- After driving the vehicle, the temperature inside the motor room is very high, so be careful when inspecting the motor room. To prevent burns, turn the ignition off and allow it to cool before inspection.
- When checking the vehicle, be sure to turn off the ignition, place the electric shift lever in the P (park) position and apply the parking brake.
- Make sure that the ignition key is OFF when performing any works in an enclosed space such as a garage.
- Always turn off the ignition and do not smoke or allow open flames (or sparks) near the vehicle when checking low voltage (12 V) battery, washer fluid and brake fluid, etc.
- Never connect or disconnect the low voltage (12 V) battery while the ignition switch is ON.
- Remember that the low battery (12 V) cable and vehicle wiring carry high currents and voltage. Be careful not to cause a short circuit.
- Keep the used oil, coolant and other liquids out of reach of children.
(Please contact a specialized company when discarding it.)

Warning

- Disconnect the negative terminal of the low voltage (12 V) battery when checking the vehicle around the cooling fan or radiator as the cooling fan may rotate even when the ignition is turned off.
- Check the level of various oils and coolant daily. Driving the vehicle with insufficient oils or coolant may damage the vehicle which is not subject to warranty repair.
- Be sure to use genuine parts for replacing consumable parts.
- When you add any oil, be careful for the oil or coolant not to come into contact with your body, clothes or the painted surface of the vehicle. If it comes into contact with your body, wash it off immediately and consult your doctor.
- Adding more oil than the prescribed level may damage the systems. Always add a proper amount of oil.
- When you inject or add any oil or fluid, do not allow foreign materials such as moisture or dust to enter. Failure to do so may lower the vehicle performance and make normal functions inoperable, causing an accident while driving.

Warning

- When a long period of time has passed even if the mileage is low, the level of oils may become low. Check it frequently and add it if necessary.
- Used oils and other solutions and containers should not be discarded with household waste. Discard oils and other solutions according to a legitimate disposal procedure.

Index

You can conveniently find important functions or terms from the content of this owner's manual in alphabetical order.

2-row parking ☞ Refer to
 Double parking (2-row
 parking).....1-10, 4-182

4D Driving ☞ Refer to No
 Drugged, Drunk, Distracted and
 Drowsy (4D) Driving.....1-30

A

ACC status (START/STOP
 switch)4-2

AC inverter3-94

Activating/deactivating the
 warning buzzer of rear and side
 warning system4-150

Adjusting the angle of the
 backrest.....3-8, 3-10

Adjusting the angle of the head
 light.....3-58

Adjusting the headrest3-6, 3-11

Adjusting the height/length of the
 steering wheel.....3-88

Adjusting the operation speed of
 the windshield wiper.....3-73

Adjusting the power seat.....3-7

Adjusting the seat manually.....3-10

Adjusting the temperature of
 the driver seat and the front
 passenger seat (independent
 operation)3-82

AEBS ☞ Refer to Autonomous
 Emergency Braking System
 (AEBS).....4-141

Air bag.....2-20
 Collision detection sensor.....2-21

Air bag control module.....2-21

Air bag warning label2-20

Air bag warning lamp2-20, 4-21

Air conditioner3-78
 Adjusting the temperature of the
 driver seat and the front passenger
 seat (independent operation).....3-82
 Synchronizing based on the driver
 seat set temperature (SYNC)3-82

Android device.....3-89

An infant or a small child must
 be seated in the rear seat with
 protective gear.....1-31

Antenna (GPS, radio, DAB (EU),
 GSM (E-call)).....3-92

Anti-Lock Brake System
 (ABS).....4-129

Anti-Lock Brake System (ABS)
 warning light.....4-24, 4-130

Anti-pinch protection function of
 the power tailgate.....3-27

Anti-theft and warning system.....2-35

Auto approach lamp
 Goodbye mode3-62
 Welcome mode.....3-62

Auto defogger system.....3-86

Auto door lock function at the
 time of driving.....3-3

Auto door unlock function at the
 time of collision.....3-3

AUTO HOLD4-139

AUTO HOLD indicator/warning
 light.....4-30

AUTO HOLD ☞ Refer to AUTO
 HOLD.....4-139

Auto light3-56, 3-64

Automatic transmission equipped
 vehicle
 What is creep?.....4-106

Automatic transmission selector
 lever
 How to move shift lever to target
 gear position4-101

Autonomous Emergency Braking
 System (AEBS)4-141

Autonomous Emergency Braking
 System (AEBS) OFF indicator4-27

Autonomous Emergency Braking
 System (AEBS) warning light.....4-26

Average fuel economy
 (instrument cluster display)4-37

Average speed (display of the
 instrument cluster).....4-37

AV/Navigation3-90

AV screen (display of the
 instrument cluster).....4-40

B

BBS warning lamp.....4-25

Be Careful not to Have a Part of
 Your Body Caught When Using
 the Power Window1-32

Blind spot detection (BSD) system
 RCTW System4-153

Blind Spot Detection (BSD)
 system4-152

Bluetooth3-89

Bluetooth hands-free.....3-91

Brake system.....4-127
 ABS (Anti-Lock Brake System) ..4-129
 Electronic Brake-Force
 Distribution (EBD).....4-130
 Foot brake.....4-128
 What is the fade phenomenon? .4-128
 What is the vapor lock
 phenomenon?.....4-128

Brake system warning light.....4-22

Breaking in a New Vehicle
 Correctly1-38

BSD system ☞ Refer to the
 Blind Spot Detection (BSD)
 system4-152

C	Certification Label.....	1-20	Checking the tires and wheels.....	6-28	Digital speedometer (display of the instrument cluster).....	4-39	
Card holder.....	3-96	Change of specifications (options) and functions according to a change of design	4	Checking the wheels ☞ Refer to 'Checking the tires and wheels' ...	6-28	Do Not Drive with the Doors or Tailgate Open	1-32
Care and Cleaning of the Interior	1-41	Charge Information (instrument cluster display)	4-38	Checking the wipers and replacing the blade.....	6-14	Do Not Drive With the Tailgate or Doors Open	1-32
Car play.....	3-89	Charging		Child restraint for an infant or a small child.....	2-11	Do Not Hold a Part of Your Body Out of the Sunroof or Window	1-32
Cases where the air bag does not inflate.....	2-24	Fast charging.....	3-35	Child restraint ☞ Refer to 'Child restraint for an infant or a small child'	2-11	Do Not Hold a Part of Your Body Out of the Window or Sunroof	1-32
Cautions for Attaching Accessories	1-36	Portable charger	3-36	Child safety door lock.....	3-4	Do Not Load Hazardous Materials	1-36
Cautions for parking during winter	6-33	Slow charging.....	3-35	Cleaning and Maintaining Glass ..	1-41	Do not Stop the Engine While Driving	1-33
Cautions for parking the vehicle on a downhill road.....	4-138	Charging connector lock	3-40	Collision detection sensor	2-21	Do not use vehicle components for other purposes.....	4
Cautions for parking the vehicle on a uphill road.....	4-138	Charging indicator	3-41, 4-32	Coming home light.....	3-63	Door.....	3-2
Cautions for Polishing the Vehicle.....	1-40	Charging type and precautions....	3-35	Connecting and disconnecting of charging connector.....	3-38	Auto door lock function at the time of driving	3-3
Cautions for the Depletion of Battery when Connecting Uninterruptible Power Supply to the Black Box System.....	1-38	Check for Any Vehicles or Person Passing by When Getting Out	1-33	Console	3-100	Auto door unlock function at the time of collision	3-3
Cautions for the Protection of the Environment	1-5	Checking and replacing fuses and relays.....	6-16	Crossing an Intersection or Railroad Crossing.....	1-35	Child safety door lock	3-4
Cautions for using smart key / REKES key.....	4-13	Checking and replacing the brake discs	4-129	Crossing a Railroad Crossing or Intersection.....	1-35	Door ajar warning light.....	4-33
Cautions for Using the Vehicle Key	1-42	Checking and replacing the brake pads.....	4-129	Cup holder.....	3-98	Door handle switch.....	4-11
Cautions for Vehicle Ventilation ...	1-37	Checking and replacing the lamps.....	6-18	D		Door map pocket.....	3-100
Cautions for Window Tinting	1-41	Replacing exterior lamps	6-21	Daytime Running Light (DRL).....	3-59	Door open lever.....	3-2
Center room lamp	3-67	Replacing the interior lamps.....	6-23	Delayed Accelerator Pedal Response ☞ Refer to System Protection Function (Delayed Accelerator Pedal Response)	1-37	Double parking (2-row parking).....	1-10, 4-182
		Checking Before Driving	1-25			Drive mode switch.....	4-107
		Checking Motor Room	6-8				
		Checking the status of tire wear ..	6-29				
		Checking the tire pressure	6-28				

Driver seat window safety function.....	3-18
Driving on a Downhill Road and Hillside Road.....	1-34
Driving on a Hillside Road and Downhill Road.....	1-34
Driving on a Muddy or Sandy Road.....	1-34
Driving on an Icy and Snowy Road.....	1-34
Driving on a River or a Road with a Pool of Water.....	1-35
Driving on a Road with a Pool of Water or a River.....	1-35
Driving on a Sandy or Muddy Road.....	1-34
Driving on a Snowy or Icy Road..	1-34
Driving on Mountains and Unpaved Roads.....	1-33
Driving on the Expressway.....	1-35
Driving on Unpaved and Mountain Roads.....	1-33
Driving Position.....	1-28
Driving time (display of the instrument cluster).....	4-37
DRL ☞ Refer to 'Daytime Running Light (DRL)'	3-59

E

EBD ☞ Refer to Electronic Brake-Force Distribution (EBD).....	4-130
ECM room mirror.....	3-76
ECO indicator.....	4-28
ECO+ indicator.....	4-29
Electric power steering warning light.....	4-22
Electronic Brake-Force Distribution (EBD).....	4-130
Electronic Brake-Force Distribution (EBD) warning light.....	4-24, 4-130
Electronic Parking Brake (EPB).....	4-136
Electronic Parking Brake (EPB) auto unlock.....	4-137
Electronic Parking Brake (EPB) emergency mode.....	4-137
Electronic Parking Brake (EPB) warning light.....	4-26
Electronic stability control system (ESP).....	4-132
Electronic stability control system (ESP) OFF indicator.....	4-23
Electronic stability control system (ESP) ON indicator/warning light.....	4-23

Emergency key.....	4-14
Emergency measures in case of emergency.....	1-10
Lift and mounting points.....	1-11
Stationary vehicle (OFF).....	1-11
To change P (park) position.....	1-10
To cutoff power from low voltage (12 V) battery.....	1-15
To turn ignition off while driving (in case of emergency).....	1-12
Emergency measures in the event of emergency.....	5-1
In the event of a fire.....	5-23
In the event of a heavy snow.....	5-25
In the event of an accident.....	5-22
When a tire is flat.....	5-5
When the vehicle has stopped due to a failure.....	5-21
When you need to have your vehicle towed.....	5-14
Emergency Stop Signal (ESS)...	4-131
Engine Check Indicator.....	1-42, 1-44
EPB ☞ Refer to 'Electronic Parking Brake (EPB)'	4-136
ESP ☞ Refer to 'Electronic stability control system (ESP)'	4-132
ESS ☞ Refer to Emergency Stop Signal (ESS).....	4-131
EV charge port door.....	3-34
Extinguisher.....	1-37, 5-23

F

Fastening the seat belt by a pregnant woman.....	2-9
Foot brake.....	4-128
Front auto washer.....	3-73
Front Camera Module (FCM).....	4-157
Front fog lamp ON indicator.....	4-28
Front fog light.....	3-56
Front obstacle detection sensor.....	4-175
Front obstacle detection warning ON/OFF switch.....	4-175
Front/rear obstacle detection system.....	4-175
Front obstacle detection sensor.....	4-175
Rear obstacle detection sensor.....	4-175
Front room lamp (overhead console).....	3-66
Front storage.....	3-98
Front windshield and washer fluid linkage.....	3-73
Fuel economy information (instrument cluster display).....	4-37
Functions for each shift position.....	4-102
D (drive) position.....	4-103
N (neutral) position.....	4-103

P (park) position 4-102
R (reverse) position 4-102

G

Glass heater 3-84
Global warning light 4-25
Glove box 3-99
Glove box lamp 3-72
Goodbye mode 3-62
Grip handle/coat hanger 3-97

H

Hazard warning lamp 3-57, 4-27
HBA ☞ Refer to 'High Beam Assist (HBA)' 3-60
HDC ☞ Refer to Hill Descent Control (HDC) 4-134
Head light 3-56
Headlight ☞ Refer to 'Headlight' 3-56
Heater 3-78
 Adjusting the temperature of the driver seat and the front passenger seat (independent operation) 3-82
 Synchronizing based on the driver seat set temperature (SYNC) 3-82
Heater and A/C controller 3-81

Heating and ventilation ☞ Refer to 'Seat ventilation and heating' ... 3-13

Heating mode switch 3-86
High beam 3-57
High Beam Assist (HBA) 3-56, 3-60
High beam indicator 4-31
High mounted stop lamp 3-55, 6-20
High voltage (drive) battery 1-7
High voltage warning lamp 1-44
Hill Descent Control (HDC) 4-134
Hill Descent Control (HDC) ON indicator/warning light 4-22, 4-135
Horn 3-88
Horn ☞ Refer to 'Horn' 3-88
How to perform scheduled charging 3-54
HV battery fault warning light 4-33
HV battery level warning light 4-32

I

Illumination ON indicator 4-27
Immobilizer system 2-35
Immobilizer system warning light 4-26
Importance of a periodic check 4
Indicator panel on instrument cluster 4-35

Inflating a tire 5-12

Information Regarding the Installation of Accident Recording Devices and Provision of Information 1-2
Infotainment system 3-89
Installing a snow tire 6-32
Installing the towing hook 5-15
Instantaneous fuel economy (instrument cluster display) 4-38
Instrument cluster 4-16
 Trip computer information 4-37
Instrument cluster illumination brightness 4-99
Instrument cluster warning lights and indicators 4-21
Intelligent / Adaptive Cruise Control 4-108
Interior fuse box 6-16
Interior temperature sensor 3-78
In the event of a fire 5-23
In the event of a heavy snow 5-25
In the event of an accident 5-22
iPod 3-91

K

Klaxon ☞ Refer to 'Horn' 3-88

Korea Consumer Agency - Precautions for Potentially Hazardous Seat Belt related Goods 1-3

Korea Consumer Agency - Precautions for the reduction of non-crash incidents 1-4, 1-18

L

Lane Change Assist (LCA) system 4-152
Lane Keeping Assistance System (LKAS) 4-163
LCA system ☞ Refer to the 'Lane Change Assist (LCA) system' 4-152
LDWS (Lane Departure Warning System) 4-157
LDWS ☞ Refer to LDWS (Lane Departure Warning System) 4-157
License plate lamp 3-55, 6-20
Lift and mounting points 1-11
Lights and lamps 3-55
 Turning off all lights 3-56
Light switch 3-56
Living home light 3-63
LKAS (LDWS) indicator / warning lamp 4-30
Load limiter 2-8

Long-term parking mode	1-38
Luggage compartment	3-103
Board	3-104
Luggage net	3-105
Luggage room lamp	3-67
Luggage upper cover	3-103
LV battery warning light.....	4-21

M

Main menu on the instrument cluster.....	4-35
MAINTENANCE SCHEDULE.....	6-2
Managing the A/C (winter)	6-32
Managing the engine coolant (winter).....	6-32
Managing washer fluid (winter)....	6-32
Manual tailgate	3-24
Message message on the display of the instrument cluster.....	4-47
Mileage (display of the instrument cluster).....	4-37
Mirror	3-75
ECM room mirror	3-76
Outside rearview mirror control button	3-75
Mirror and lamp.....	3-96
Mood lamp*	3-72

Motor room	3-32
Motor room fuse and relay box....	6-16
Motor room hood open warning light.....	4-34

N

Navigation Refer to 'AV/Navigation'.....	3-90
No Drugged, Drunk, Distracted and Drowsy (4D) Driving.....	1-30
Non-crash incident Refer to Korea Consumer Agency - Precautions for the reduction of non-crash incidents	1-4, 1-18
No Sleeping in a Sealed Vehicle .	1-31
No Sudden Maneuvering of the Steering Wheel.....	1-35, 1-36
No Sudden Starting, Acceleration, or Braking.....	1-33, 1-34

O

OFF status (START/STOP switch)	4-2
Oils capacity/specifications	6-3
ON status (START/STOP switch)	4-2
Opening the motor room.....	3-32



Opening the tailgate in the event of emergency.....	3-30
Operating smart audio and AV/ navigation using the steering wheel	3-91
Operating status and faults of control box.....	3-46
Outside rearview mirror auto folding/unfolding function.....	3-75
Outside rearview mirror control button.....	3-75
OVM Refer to 'OVM tools'	5-2
OVM tools.....	1-15, 5-2

P

Panic mode	4-9
Parking	
Cautions for parking during winter	6-33
Safe Parking and Stopping.....	1-33
When parking the vehicle on a downhill road.....	4-138
When parking the vehicle on a uphill road	4-138
Parking assist system	4-175
Front/rear obstacle detection system.....	4-175
Rear camera system	4-180
Passing light Refer to 'Turning on the high beam and low beam at the same time (passing light)'.....	3-57
Periodic Checkup And Change Interval	
Table for check and change intervals under demanding conditions	6-7
Table for check and change intervals under normal conditions	6-4
Portable charger	3-46
Charging procedures	3-48
Potentially hazardous seat belt related goods Refer to the Korea Consumer Agency - Precautions for Potentially Hazardous Seat Belt related Goods.....	1-3
Power consumption (instrument cluster display)	4-38
Power down warning light.....	4-32
Power flow (instrument cluster display)	4-39
Power socket.....	3-93
Power tailgate.....	3-25
Power window Refer to 'Window (power window)'.....	3-17
Precautions for infants, children, old people, or pregnant women ...	1-31

Precautions for the Modification of the Vehicle and Structural Alteration	1-23
Prescribed tire inflation pressure.....	6-28
Pretensioner	2-8
Puddle lamp	3-55, 6-20
Purpose and application conditions of the instruction manual.....	3

R

Rain sensing wiper.....	3-74
Rain sensor	3-74
RCTA system  Refer to Rear Cross Traffic Alert (RCTA) system.....	4-153
READY status (START/STOP switch)	4-2
Rear and side warning system ..	4-149
Blind Spot Detection (BSD) system.....	4-152
Lane Change Assist (LCA) system.....	4-152
Rear camera system	4-180
Rear cross traffic assist (RCTA) system	4-154
Rear fog lamp ON indicator	4-28
Rear lamp.....	3-55, 6-20
Rear obstacle detection sensor.....	4-175
Rear seat.....	3-11
Heating function (heater)	3-15
Rear seat backrest folding.....	3-12
Seatback reclining adjustment.....	3-11
Rear seat window lock function ...	3-19
Rear window wiper washer fluid linkage function	3-74
Regenerative braking system....	4-104
Regenerative braking warning light.....	4-24
Removing moisture on the glass	3-85
Repairing a flat tire.....	5-7
Repairing a flat tire  Refer to 'Repairing a flat tire'	5-7
Replacing A/C refrigerant/oil	3-79
Replacing exterior lamps.....	6-21
Replacing the A/C filter	6-26
Replacing the interior lamps	6-23
Replacing the smart key battery ..	4-15
Resetting the average speed (display of the instrument cluster).....	4-37
Resetting the driving time (display of the instrument cluster).....	4-37

Resetting the mileage (display of the instrument cluster).....	4-37
Resetting the opening height of the power tailgate.....	3-27
Resetting the power tailgate	3-27
Resetting the sunroof	3-23
Roof rack.....	3-106
Rotating the tire positions	6-29

S

Safe Parking and Stopping	1-33
Safety and Cautions for Driving... 1-30	
Safety exit warning (SEW) system	4-156
Safety Speed Assist (SSA)	4-121
SBW (shift by wire)	4-100
Scheduled charging.....	3-54
SD card (navigation)	3-90
Seat	
Seat & adjustment switch / button / lever	3-5
Ventilation and heating	3-13
Smart front seat heating control ...	3-14
Seatback reclining adjustment	3-11
Seat backrest pocket.....	3-101
Seat belt	2-2
Fastening the seat belt by a pregnant woman	2-9
Load limiter	2-8
Pretensioner.....	2-8
Warnings.....	2-9
Seat Belt	
Wearing the Seat Belt Correctly ...	1-29
Seat belt warning lamp	4-21
Service kit for tire repair.....	5-6
Service required warning light.....	4-31
Setting the sensitivity of the forward collision warning for Autonomous Emergency Braking System (AEBS)	4-143
SHB indicator	4-29
Side repeater.....	3-55, 6-20
Slots for multimedia.....	3-91
Slow and fast charging.....	3-42
After completing charging....	3-44, 3-51
Charging procedures	3-42
Smart audio*	3-89
Smart door auto lock (auto close).....	4-10
Smart front seat heating control... 3-14	
Smart key	4-7
Panic mode.....	4-9
Smart key warning light.....	4-26
Smart tailgate	3-28
Smart tailgate indicator	4-34

Snow tire	6-29	Steering wheel heater indicator Heating.....	4-25	T	To charge immediately after canceling scheduled charging.....	3-54	
Solar radiation sensor	3-87	Stopping the engine	4-5	Table for check and change intervals under demanding conditions	6-7	To cutoff power from high voltage battery.....	1-13
Special Cautions When Checking the Coolant	1-36	Stopping the engine while driving (in the event of emergency)	4-5	Table for check and change intervals under normal conditions ..	6-4	To cutoff power from low voltage (12 V) battery	1-15
Speed Limit Warning (TSW)	4-125	Stopping the engine while driving (in the event of emergency)	4-5	Table of Vehicle Specifications.....	1-22	To fit towing hook	1-16
SPORT indicator	4-29	Stopping the smart tailgate function	3-29	Tailgate	3-24	To set intelligent cruise control (IACC).....	4-109
SSA control		Storage unit	3-98	Anti-pinch protection function of the power tailgate	3-27	To start vehicle	4-3
SSA operation.....	4-122	Console.....	3-100	Manual tailgate	3-24	Getting your vehicle started.....	4-3
Starting the engine		Cup holder	3-98	Opening the tailgate in the event of emergency	3-30	To start vehicle.....	4-3
Starting the engine using the jump cable	5-3	Door map pocket	3-100	Power tailgate	3-25	To turn ignition off while driving (in case of emergency)	1-12
Starting the engine and driving the vehicle (winter).....	6-32	Front storage	3-98	Resetting the opening height of the power tailgate	3-27	To use regenerative braking.....	1-36
Starting the engine using the jump cable	5-3	Glove box.....	3-99	Resetting the power tailgate.....	3-27	TPMS  Refer to the tire pressure monitoring system (TPMS)	2-29
Starting the engine with a depleted smart key or interference (in the event of emergency).....	4-4	Seat backrest pocket	3-101	Smart tailgate.....	3-28	TPMS (Tire Pressure Monitoring System)	
START/STOP switch	4-2	Sunglass holder.....	3-99	Stopping the smart tailgate function	3-29	Display of the TPMS status on the instrument cluster	4-39
ACC status.....	4-2	Sunroof	3-20	Tail light	3-56	Trip computer information	4-37
OFF status	4-2	Sunroof open warning.....	3-22	TBT (Turn By Turn) (display of the instrument cluster).....	4-41	Trip info display	4-18
ON status.....	4-2	Sunroof safety function	3-22	Tips when an accident or a malfunction occurs on the expressway.....	5-22	TSR (Traffic signal recognition)..	4-174
READY status.....	4-2	Sun visor	3-96	Tire chain.....	6-30	Turning on the high beam and low beam at the same time (passing light)	3-57
Steering wheel.....	3-88	Sun visor/mirror lamp.....	3-68, 3-96	Tire pressure monitoring system (TPMS)	2-29	Turn signal.....	3-56, 4-27
Horn	3-88	Synchronizing based on the driver seat set temperature (SYNC)	3-82	Display of the TPMS status on the instrument cluster	2-31		
Steering wheel heater	3-88	System Protection Function (Delayed Accelerator Pedal Response)	1-37				

U			
Use of service centers and maintenance partners.....	4	Vehicle Washing.....	1-39
Use of Service Centers and Maintenance Partners.....	1-38	Cleaning and Maintaining Glass... ..	1-41
User settings	4-42	Washing the Bumper	1-40
User settings on the instrument cluster.....	4-42	Washing Wheels	1-40
Using a towing rope	5-16	Ventilation and heating ☞ Refer to 'Seat ventilation and heating' ...	3-13
Using a tow truck	5-14	Virtual engine sound system (VESS) warning lamp.....	4-33
Using Genuine Parts.....	1-38	Voice recognition function	3-91
		V	
V		Warning horn ☞ Refer to 'Horn'	3-88
Vehicle Identification.....	1-20	Warning lights and indicators.....	4-21
Vehicle Identification Number (VIN)	1-20	Warnings for self-maintenance	6-34
Vehicle Management.....	1-38	Warning triangle	5-2
Vehicle management during winter	6-32	Washer fluid	3-73
Cautions for parking	6-33	Washing the Bumper.....	1-40
Installing a snow tire.....	6-32	Washing Wheels	1-40
Managing the A/C.....	6-32	Wearing the Seat Belt Correctly	1-29
Managing the engine coolant.....	6-32	Welcome light.....	3-62
Managing washer fluid.....	6-32	Welcome mode	3-62
Starting the engine and driving the vehicle.....	6-32	What is creep?	4-106
Vehicle READY indicator.....	4-31	What is safety unlock?.....	4-8
Vehicle Specifications.....	1-21	What is the fade phenomenon?.....	1-36, 4-128
		What is the standing wave phenomenon?.....	1-27
		What is the vapor lock phenomenon?.....	1-36, 4-128
		What is wind buffeting?.....	3-19, 3-21
		Wheel alignment status and the balance between tires and wheels	6-28
		When a tire is flat.....	5-5
		When a tire is flat ☞ Refer to 'When a tire is flat'	5-5
		When a tow truck is unavailable (in case of emergency)	5-15
		Installing the towing hook.....	5-15
		Using a towing rope.....	5-16
		When low tire pressure is detected.....	2-33
		When Low Voltage (12 V) Battery Discharged (Emergency Start-up).....	5-3
		When the vehicle has stopped due to a failure	5-21
		When towing vehicle unavailable (in an emergency)	1-16
		To fit towing hook.....	1-16
		When vehicle does not start	4-4
		To start vehicle when stop lamp fuse fails (emergency)	4-4
		When you have rotated the tires..	2-33
		Window (power window)	3-17
		Driver seat window safety function	3-18
		Rear seat window lock function....	3-19
		Windshield fog detection sensor..	3-78
		Wiper	3-73
		Adjusting the operation speed of the windshield wiper	3-73
		Front windshield and washer fluid linkage.....	3-73
		Rain sensing wiper	3-74
		Rear window wiper washer fluid linkage function.....	3-74
		Wireless Phone Charger System*	3-101

No.	PART NO.	CODE NO.	PRINTING DATE	MODEL	REMARKS
1	EV110OM2305E	KE1-3OM0E-3E-300A	May. 01, 2023	E110	e-motion

KORANDO e-motion (LHD) OWNER'S MANUAL

ISSUED BY
EXPORT SERVICE TEAM
KG Mobility Corporation

455-12, Dongsak-ro, Pyeongtaek-si,
Gyeonggi-do, 17749, Korea

TELEPHONE : 82-80-500-5582
FACSIMILE : 82-31-610-3762

NOTE: *All rights reserved. Printed in KG Mobility Corporation.
No part of this book may be used or reproduced without the
written permission of Export Service Team.*

<https://www.automotive-manuals.net/>